

**Job Name: 25-1922 - Reynold's Farm**  
**Job Location: Goodlettsville, TN 37072**  
**Contractor: Josh King Excavation**

PC: J. Jarvis  
 TECH: K. Cardwell  
 Plant: Beaver Dam, KY



Structure ID: **C1.2**

Spec: Storm  
 Type: STM.MH Transition  
 Size: 60"

Rim: 526.48'  
 Invert: 518.55'  
 Rim to Invert: 7.93'

Sump: 3"  
 Floor (Top): 518.3'  
 Floor Height: 8"

Floor (Bot): 517.633'  
 Overall Height: 8.833'  
 Slack: 0.16"

**Structure Notes:**

- PER ASTM C-478 SPECS
- CONCRETE: 4,000 PSI AT 28 DAYS
- REINFORCEMENT:
  - CONE: PER ASTM A615
  - TRANSITION SLAB: #5 BAR @ 6" C.C. E.W. (GRADE 60)
  - BASE: PER ASTM A615
- STEPS AT 220 DEGREES
- JBS 1150 FRAME & COVER "STORM" SUPPLIED BY ICAST

**STRUCTURE SUMMARY:**

P4) 24" - CASTING HEIGHT - 7"	0 lb
P3) 48" - ECC CONE w/ 24" HOLE F/G - 36"	3000 lb
P2) 60" - MH Transition Slab 48" Hole T/F - 8"	1570 lb
P1) 60" - MH BASE Custom Ht F/n - 47"	6793 lb
1) CASTING - JBS 1150 F/C STORM	250 lb
1) 60" - Conseal CS-102 1.00"	0 lb
1) 48" - Conseal CS-102 1.00"	0 lb
2) Hole - 32	0 lb
7) MH Step ML-10-TDS-NCR - 10"	0 lb
	-----
Structure Total:	11613 lb

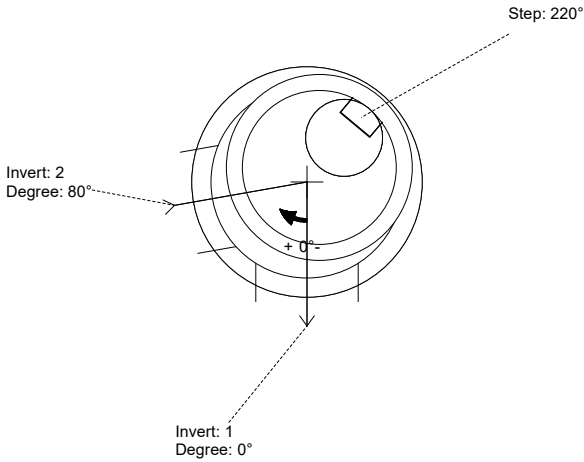

Position	Elev	Angle	Pipe	Pipe OD	Hole	Connector	Up (")	Ref
Rim	526.48'							
Reducer	522.217'							
Invert 1	518.55'	0°	24" RCP B WALL	30"	32"	Hole 32	0"	P1
Invert 2	518.65'	80°	24" RCP B WALL	30"	32"	Hole 32	1.2"	P1
Invert 3								
Invert 4								
Invert 5								
Invert 6								
Invert 7								
Invert 8								

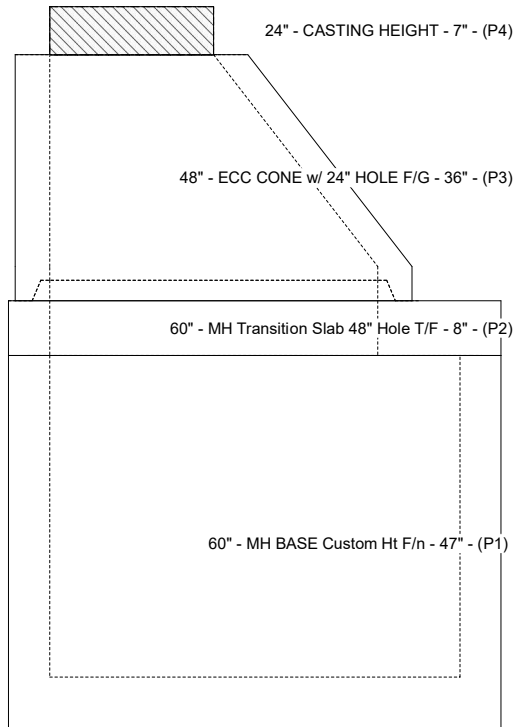

**Cast (Int. Dim.) - Interior Dimensions**

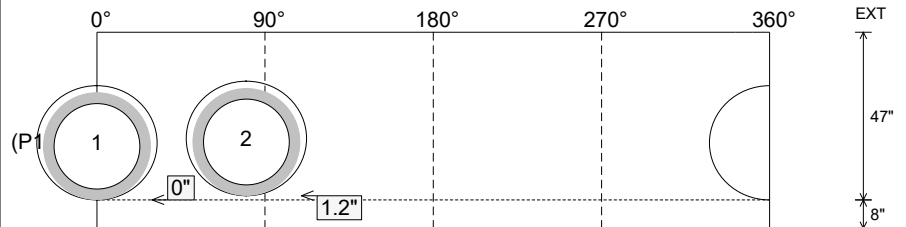

Submittal Drawing  
 1/8/2026 7:55:09 AM

SUBMITTAL  
 APPROVED BY: