

Job Name: 25-1922 - Reynold's Farm
 Job Location: Goodlettsville, TN 37072
 Contractor: Josh King Excavation

Plant: Beaver Dam, KY
 10/7/2025 12:52:11 PM

Tech: K. Cardwell
 PC: J. Jarvis



Structure ID: C1.1 (MH)

P2 MH048CN36

ECC CONE w/ 24" HOLE F/G

- P4) 24" - CASTING HEIGHT - 7"
- P3) 24" - GRADE RING F/F - 4"
- P2) 48" - ECC CONE w/ 24" HOLE F/G - 36"
- P1) 48" - MH BASE T/n - 48"
- 1) CASTING - JBS 1150 F/C STORM
- 1) 48" - Conseal CS-102 1.00"
- 2) Hole - 32
- 1) Hole - 22
- 7) MH Step ML-10-TDS-NCR - 10"

Structure Notes:

1. PER ASTM C-478 SPECS
2. CONCRETE: 4,000 PSI AT 28 DAYS
3. REINFORCEMENT: PER ASTM A615
4. STEPS AT 270 DEGREES
5. JBS 1150 FRAME & COVER "STORM" SUPPLIED BY ICAST

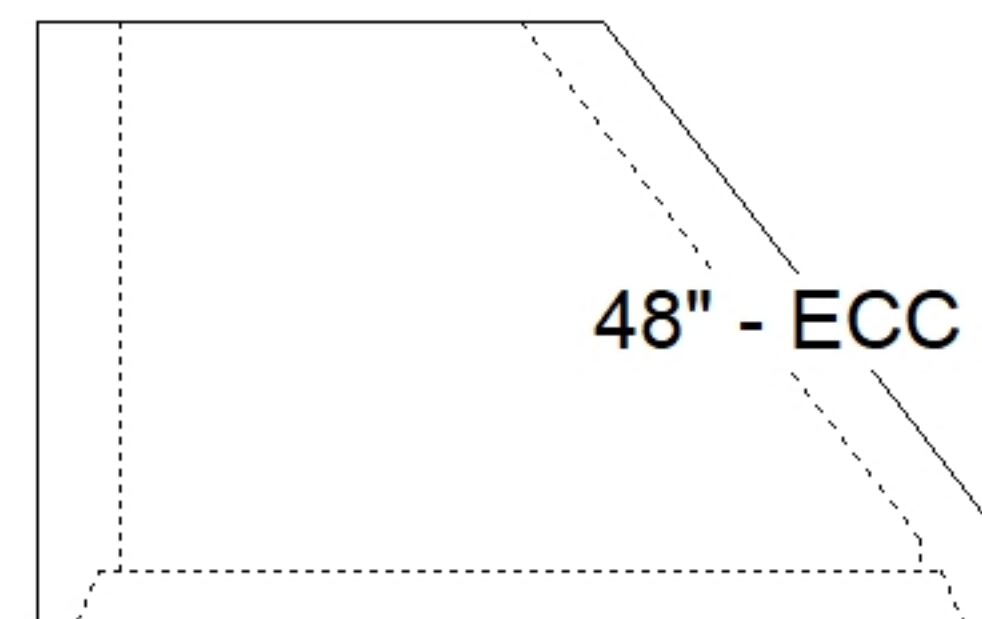
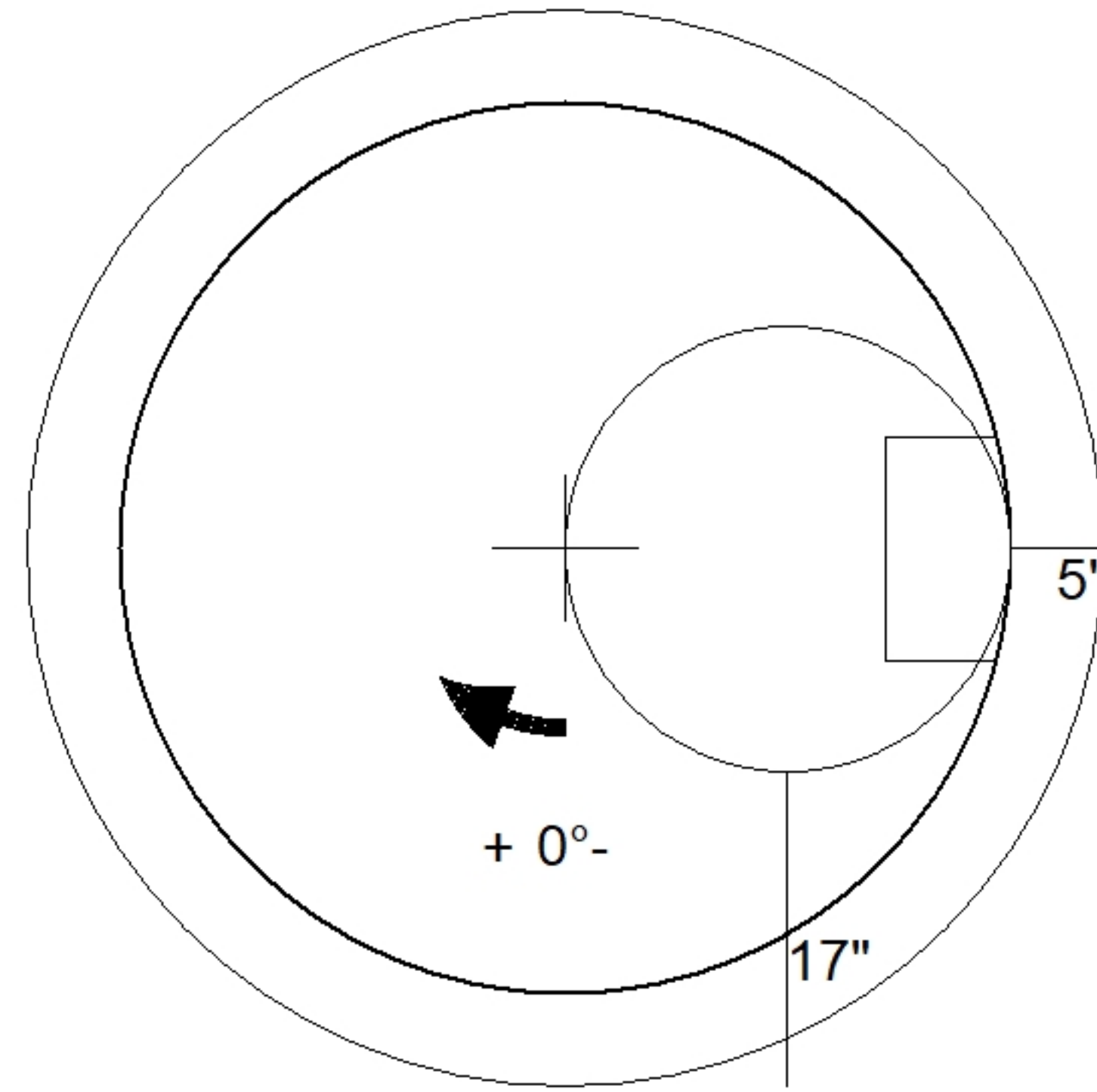

48" - ECC CONE w/ 24" HOLE F/G - 36" - (P2)

Coating (Int): Coating (Ext):	Seam Up: Flat Seam Dn: Groove	Wall Thickness: 5"	Height (Ext): 36"	Weight (Net): 3000 lb Volume (Net): 0.5cu.yd
----------------------------------	----------------------------------	--------------------	-------------------	---