

Job Name: 25-1922 - Reynold's Farm
Job Location: Goodlettsville, TN 37072
Contractor: Josh King Excavation

PC: J. Jarvis
 TECH: K. Cardwell
 Plant: Beaver Dam, KY



Structure ID: **B6**
 Spec: Storm
 Type: STM.MH
 Size: 48"

Rim: 531.5'
 Invert: 526.4'
 Rim to Invert: 5.1'

Sump: 2"
 Floor (Top): 526.233'
 Floor Height: 6"

Floor (Bot): 525.733'
 Overall Height: 5.625'
 Slack: 1.7"

Structure Notes:

1. PER ASTM C-478 SPECS
2. CONCRETE: 4,000 PSI AT 28 DAYS
3. REINFORCEMENT:
 - FLAT LID: #4 BAR @ 10" C.C. E.W. (GRADE 60)
 - BASE: PER ASTM A615
4. STEPS AT 107 DEGREES
5. JBS 3300 FRAME, GRATE, & CURB HOOD SUPPLIED BY ICAST

STRUCTURE SUMMARY:

- P3) 28" x 28" - CASTING HEIGHT - 7.50" 0 lb
 - P2) 48" - MH FLAT TOP w/28"x28" Hole F/G - 12" 1368 lb
 - P1) 48" - MH BASE T/n - 42" 4046 lb
 - 1) CASTING - JBS 3300 SET (F/G/H) 500 lb
 - 1) 48" - Conseal CS-102 1.00" 0 lb
 - 1) 28" x 28" - Conseal CS-102 1.00" 0 lb
 - 2) Hole - 18 0 lb
 - 3) MH Step ML-10-TDS-NCR - 10" 0 lb
- Structure Total: **5914 lb**

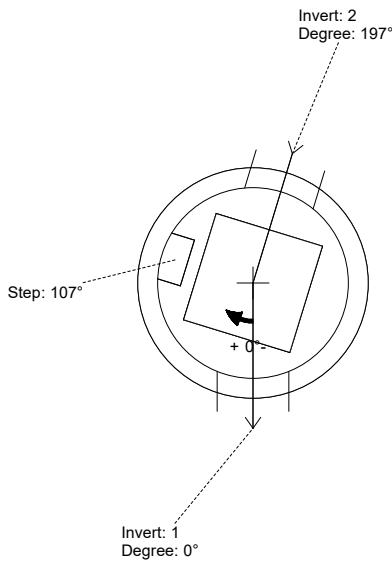

Position	Elev	Angle	Pipe	Pipe OD	Hole	Connector	Up (")	Ref
Rim	531.5'							
Reducer								
Invert 1	526.4'	0°	12" RCP B WALL	16"	18"	Hole 18	0"	P1
Invert 2	526.5'	197°	12" RCP B WALL	16"	18"	Hole 18	1.2"	P1
Invert 3								
Invert 4								
Invert 5								
Invert 6								
Invert 7								
Invert 8								

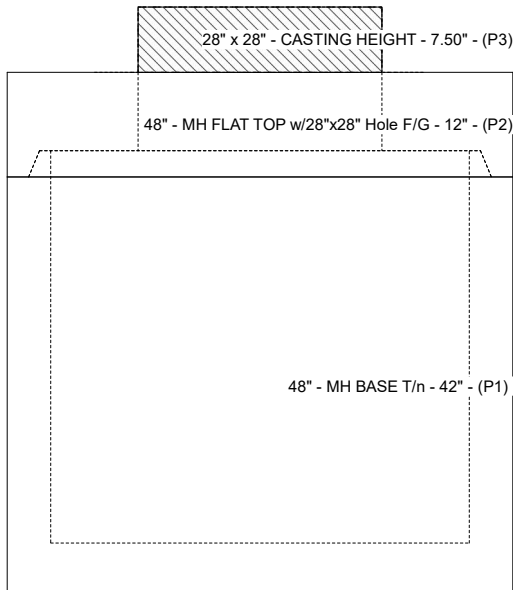

Cast (Int. Dim.) - Interior Dimensions

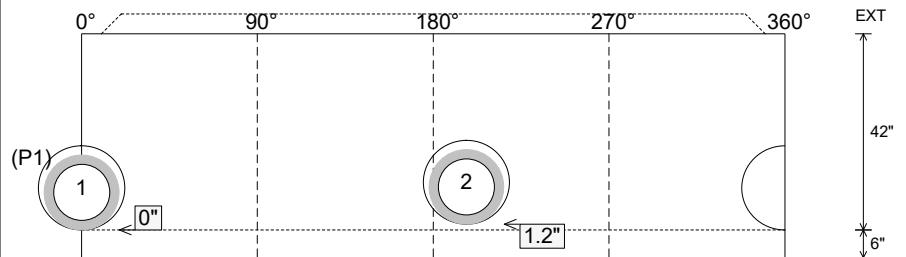

Submittal Drawing
 1/8/2026 7:55:04 AM

SUBMITTAL
 APPROVED BY: