

Job Name: 25-1922 - Reynold's Farm  
 Job Location: Goodlettsville, TN 37072  
 Contractor: Josh King Excavation

Plant: Beaver Dam, KY  
 1/8/2026 9:01:30 AM

Tech: K. Cardwell  
 PC: J. Jarvis



**Structure ID: B3**

**P2 MH060LD13-28SQ**

**MH FLAT TOP w/28"x28" Hole F/G**

- P3) 28" x 28" - CASTING HEIGHT - 7.50"
- P2) 60" - MH FLAT TOP w/28"x28" Hole F/G - 13"
- P1) 60" - MH BASE Custom Ht T/n - 63"
- 1) CASTING - JBS 3300 SET (F/G/H)
- 1) 60" - Conseal CS-102 1.00"
- 1) 28" x 28" - Conseal CS-102 1.00"
- 1) Hole - 26
- 2) Hole - 22
- 5) MH Step ML-10-TDS-NCR - 10"

0 lb  
 2645 lb  
 8635 lb  
 500 lb  
 0 lb  
 0 lb  
 0 lb  
 0 lb  
 0 lb  
 0 lb  
 Structure Total: 11780 lb

- Structure Notes:
1. PER ASTM C-478 SPECS
  2. CONCRETE: 4,000 PSI AT 28 DAYS
  3. REINFORCEMENT: #5 BAR @ 6" C.C. E.W. (GRADE 60) - 2" MIN. REBAR CLEARANCE (TYP)
  4. STEPS AT 256 DEGREES
  5. JBS 3300 FRAME, GRATE, & CURB HOOD SUPPLIED BY ICAST
  6. LIFTERS: 4 EA. WRA016 CONAC WIRE ROPE ANCHORS FOR PLANT & FIELD HANDLING

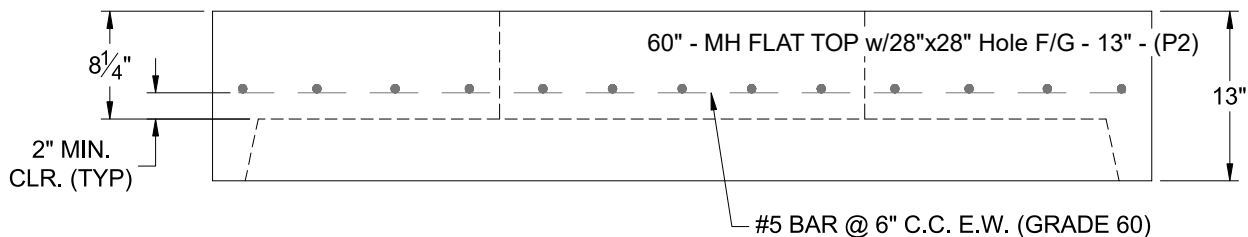
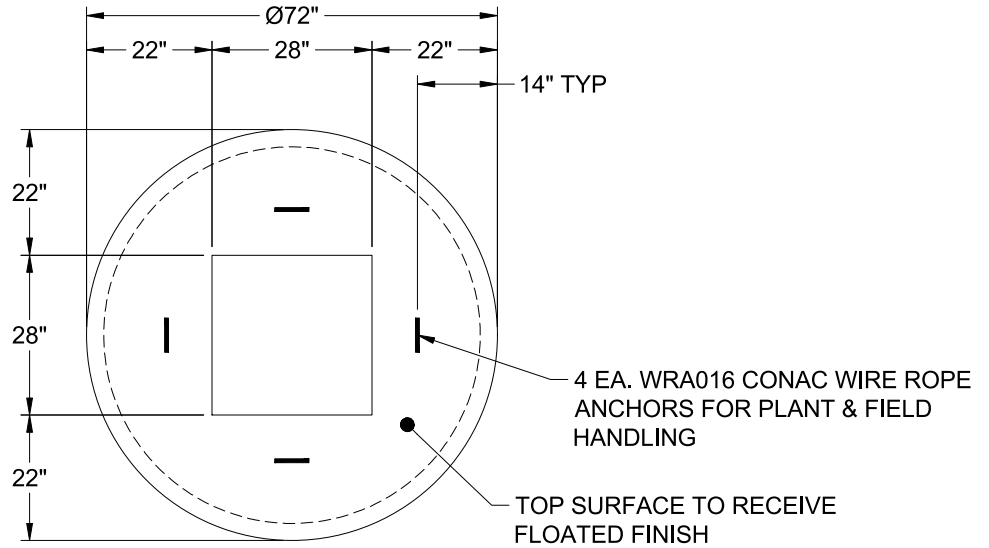

Coating (Int): Coating (Ext):	Seam Up: Flat Seam Dn: Groove	Wall Thickness: 6"	Height (Ext): 13"	Weight (Net): 2645 lb Volume (Net): 0.68cu.yd
----------------------------------	----------------------------------	--------------------	-------------------	--