

Job Name: 25-1922 - Reynold's Farm
 Job Location: Goodlettsville, TN 37072
 Contractor: Josh King Excavation

Plant: Beaver Dam, KY
 1/8/2026 9:00:25 AM

Tech: K. Cardwell
 PC: J. Jarvis



Structure ID: B3

P1 MH060BAVF

MH BASE Custom Ht T/n

- P3) 28" x 28" - CASTING HEIGHT - 7.50"
- P2) 60" - MH FLAT TOP w/28"x28" Hole F/G - 13"
- P1) 60" - MH BASE Custom Ht T/n - 63"
- 1) CASTING - JBS 3300 SET (F/G/H)
- 1) 60" - Conseal CS-102 1.00"
- 1) 28" x 28" - Conseal CS-102 1.00"
- 1) Hole - 26
- 2) Hole - 22
- 5) MH Step ML-10-TDS-NCR - 10"

0 lb
 2645 lb
 8635 lb
 500 lb
 0 lb
 0 lb
 0 lb
 0 lb
 0 lb
 0 lb

 Structure Total: 11780 lb

- Structure Notes:**
1. PER ASTM C-478 SPECS
 2. CONCRETE: 4,000 PSI AT 28 DAYS
 3. REINFORCEMENT: PER ASTM A615
 4. STEPS AT 256 DEGREES
 5. JBS 3300 FRAME, GRATE, & CURB HOOD SUPPLIED BY ICAST
 6. INVERT 3 (15" RCP) OFFSET 9" FROM CENTER

Rim: 526.65' Rim to Invert: 6.8' Slack: 0.6" Sump: 2.5" Step Position: 256°

| Position | Elev | Angle | Ext. (cw) | Pipe | Pipe OD | Connector | Hole | Horz Size | Up () | Offset |
|----------|---------|-------|-----------|----------------|---------|-----------|------|-----------|--------|--------|
| Invert 1 | 519.85' | 0° | 0" | 18" RCP B WALL | 23" | Hole 26 | 26" | 26.891" | 0" | 0" |
| Invert 2 | 520.1' | 116° | 72.885" | 15" RCP B WALL | 19.5" | Hole 22 | 22" | 22.525" | 3.25" | 0" |
| Invert 3 | 520.1' | 150° | 103.344" | 15" RCP B WALL | 19.5" | Hole 22 | 22" | 23.893" | 3.25" | 9" |
| Invert 4 | | | | | | | | | | |
| Invert 5 | | | | | | | | | | |
| Invert 6 | | | | | | | | | | |
| Invert 7 | | | | | | | | | | |
| Invert 8 | | | | | | | | | | |

RIGHT-SIDE UP VIEW (int. dimensions)

UPSIDE-DOWN VIEW (int. dimensions)

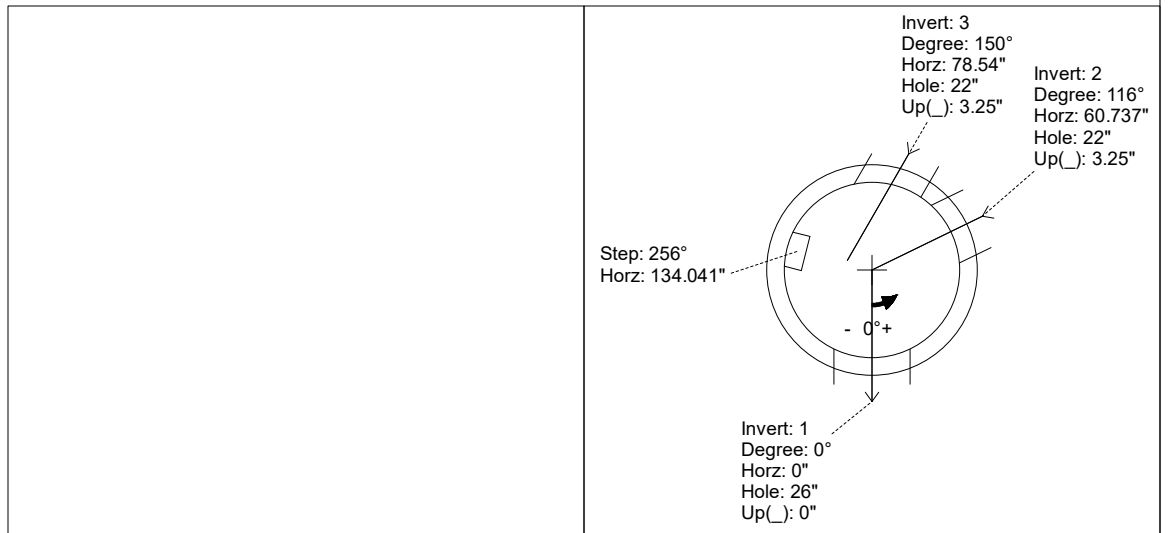
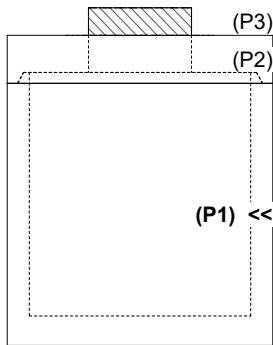

INSIDE WALL DIMENSIONS

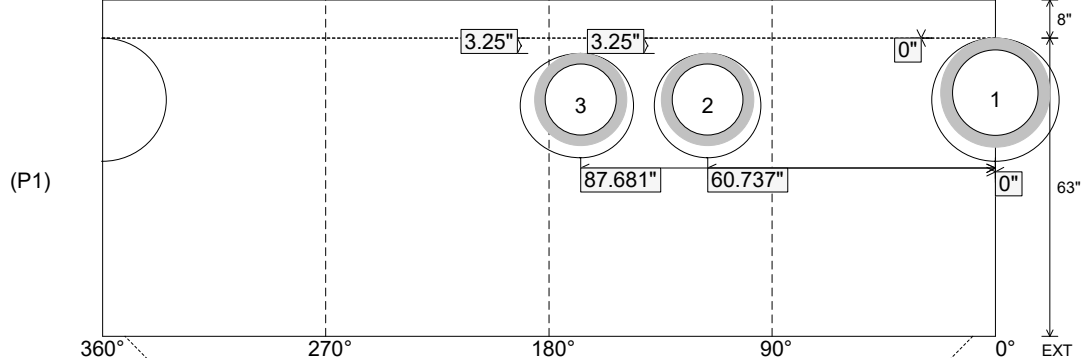

Coating (Int):
 Coating (Ext):

Seam Up: Tongue
 Seam Dn: n/a

Wall Thickness: 6"
 Floor Height: 8"

Height (Int): 63"
 Height (Ext): 71"

Weight (Net): 8635 lb
 Volume (Net): 2.21cu.yd