

Job Name: 25-1922 - Reynold's Farm  
 Job Location: Goodlettsville, TN 37072  
 Contractor: Josh King Excavation

Plant: Beaver Dam, KY  
 10/2/2025 8:39:25 AM

Tech: K. Cardwell  
 PC: J. Jarvis



**Structure ID: B2 (CB)**

**P1 MH048BA60**

**MH BASE T/n**

- P3) 30" x 30" - CASTING HEIGHT - 6"
- P2) 48" - MH FLAT TOP w/30"x30" Hole F/G - 12"
- P1) 48" - MH BASE T/n - 60"
- 1) CASTING - JBS 4310 F/G
- 1) 48" - Conseal CS-102 1.00"
- 1) 30" x 30" - Conseal CS-102 1.00"
- 2) Hole - 26
- 1) Hole - 18
- 5) MH Step ML-10-TDS-NCR - 10"

0 lb  
 1350 lb  
 4946 lb  
 500 lb  
 0 lb  
 0 lb  
 0 lb  
 0 lb  
 0 lb  
 0 lb  
 -----  
 Structure Total: 6796 lb

- Structure Notes:**
1. PER ASTM C-478 SPECS
  2. CONCRETE: 4,000 PSI AT 28 DAYS
  3. REINFORCEMENT: PER ASTM A615
  4. STEPS AT 190 DEGREES
  5. JBS 4310 FRAME & GRATE SUPPLIED BY ICAST

Rim: 525.5' Rim to Invert: 6.48' Slack: 2.26" Sump: 2.5" Step Position: 190°

Position	Elev	Angle	Ext. (cw)	Pipe	Pipe OD	Connector	Hole	Horz Size	Up ( )	Offset
Invert 1	519.02'	312°	157.917"	18" RCP B WALL	23"	Hole 26	26"	27.476"	0"	0"
Invert 2	519.12'	97°	49.096"	18" RCP B WALL	23"	Hole 26	26"	27.476"	1.2"	0"
Invert 3	521.5'	280°	141.721"	12" RCP B WALL	16"	Hole 18	18"	18.451"	30.26"	0"
Invert 4										
Invert 5										
Invert 6										
Invert 7										
Invert 8										

RIGHT-SIDE UP VIEW (int. dimensions)

UPSIDE-DOWN VIEW (int. dimensions)

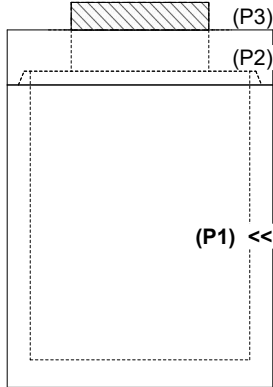
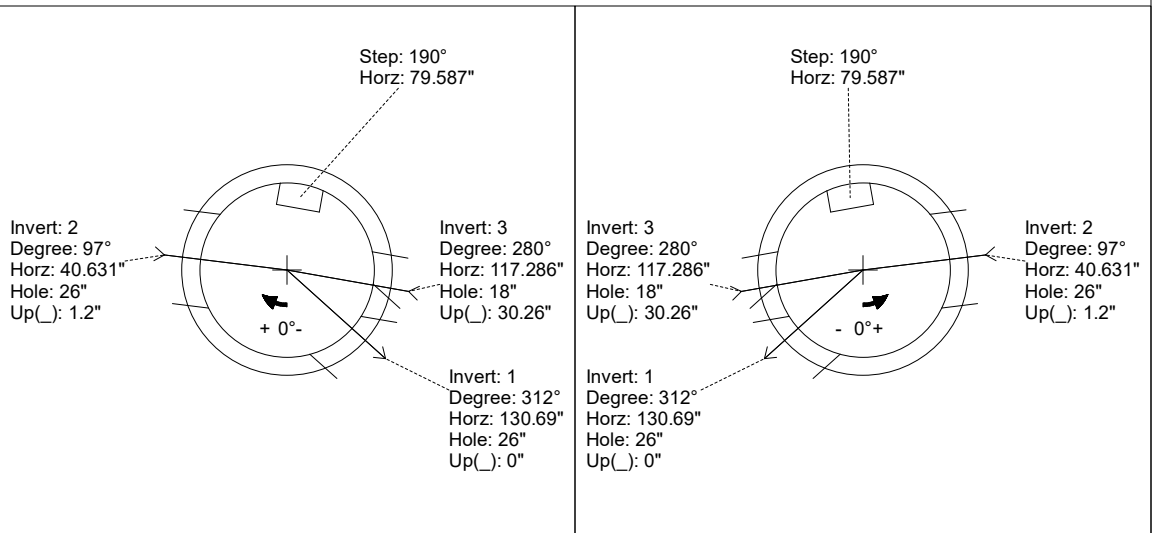

INSIDE WALL DIMENSIONS

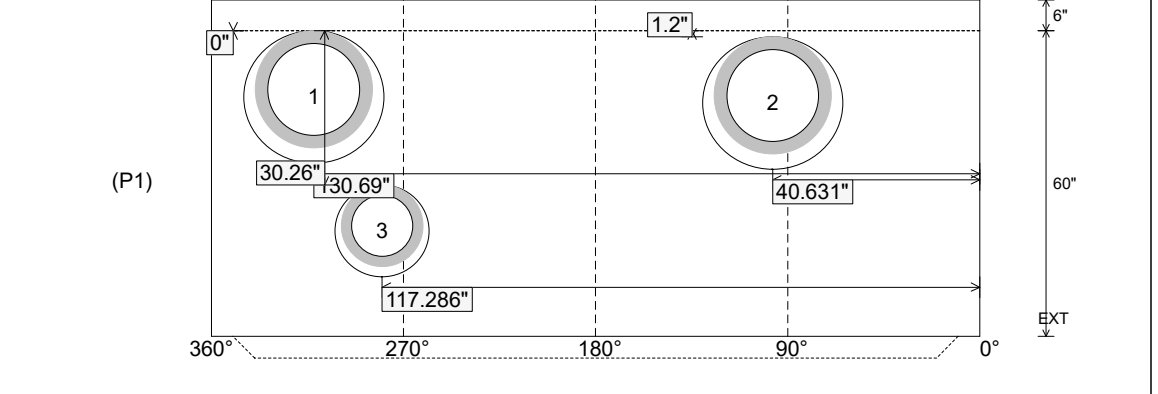

Coating (Int):  
 Coating (Ext):

Seam Up: Tongue  
 Seam Dn: n/a

Wall Thickness: 5"  
 Floor Height: 6"

Height (Int): 60"  
 Height (Ext): 66"

Weight (Net): 4946 lb  
 Volume (Net): 1.26cu.yd