

Job Name: 25-1922 - Reynold's Farm
 Job Location: Goodlettsville, TN 37072
 Contractor: Josh King Excavation

Plant: Beaver Dam, KY
 10/2/2025 8:39:24 AM

Tech: K. Cardwell
 PC: J. Jarvis



Structure ID: B1 (CB)

P1 MH048BA48

MH BASE T/n

- P4) 30" x 30" - CASTING HEIGHT - 6"
- P3) 48" - MH FLAT TOP w/30"x30" Hole F/G - 12"
- P2) 48" - MH RISER T/G - 36"
- P1) 48" - MH BASE T/n - 48"
- 1) CASTING - JBS 4310 F/G
- 2) 48" - Conseal CS-102 1.00"
- 1) 30" x 30" - Conseal CS-102 1.00"
- 1) Hole - 32
- 1) Hole - 26
- 7) MH Step ML-10-TDS-NCR - 10"

0 lb
 1350 lb
 2515 lb
 4087 lb
 500 lb
 0 lb
 0 lb
 0 lb
 0 lb
 0 lb

 Structure Total: 8452 lb

- Structure Notes:**
1. PER ASTM C-478 SPECS
 2. CONCRETE: 4,000 PSI AT 28 DAYS
 3. REINFORCEMENT: PER ASTM A615
 4. STEPS AT 90 DEGREES
 5. JBS 4310 FRAME & GRATE SUPPLIED BY ICAST

Rim: 525.5' Rim to Invert: 8.25' Slack: 0" Sump: 3" Step Position: 90°

Position	Elev	Angle	Ext. (cw)	Pipe	Pipe OD	Connector	Hole	Horz Size	Up ()	Offset
Invert 1	517.25'	336°	170.065"	24" RCP B WALL	30"	Hole 32	32"	35.027"	0"	0"
Invert 2	517.75'	187°	94.649"	18" RCP B WALL	23"	Hole 26	26"	27.476"	6.5"	0"
Invert 3										
Invert 4										
Invert 5										
Invert 6										
Invert 7										
Invert 8										

RIGHT-SIDE UP VIEW (int. dimensions)

UPSIDE-DOWN VIEW (int. dimensions)

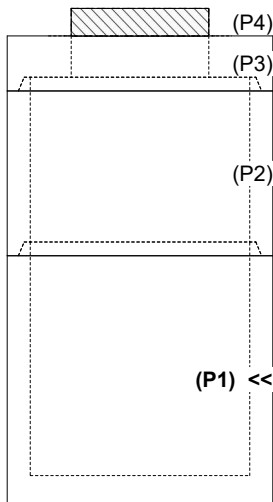
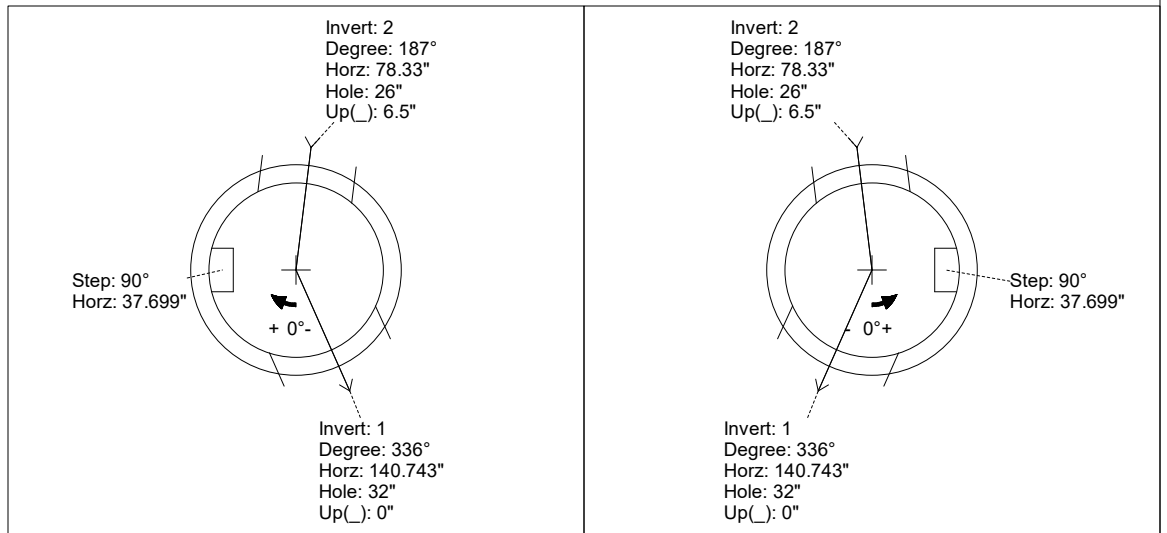

INSIDE WALL DIMENSIONS

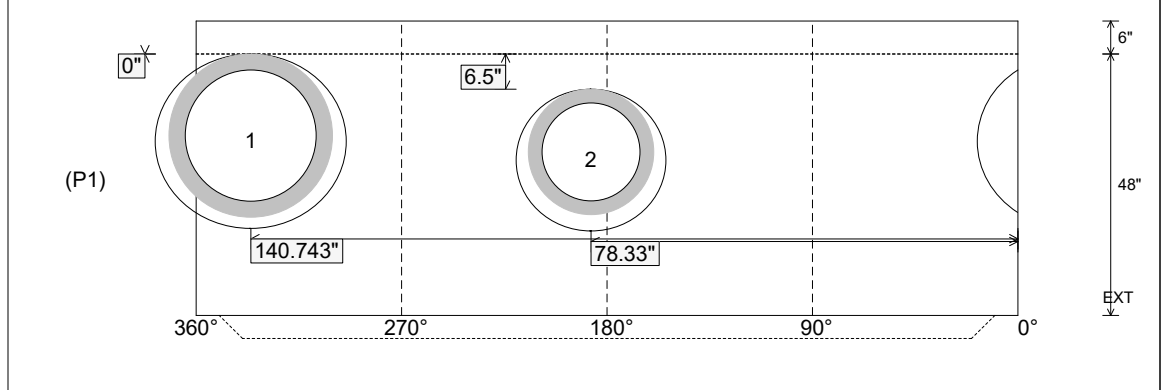

Coating (Int):
 Coating (Ext):

Seam Up: Tongue
 Seam Dn: n/a

Wall Thickness: 5"
 Floor Height: 6"

Height (Int): 48"
 Height (Ext): 54"

Weight (Net): 4087 lb
 Volume (Net): 1.04cu.yd