

Job Name: 25-1922 - Reynold's Farm  
 Job Location: Goodlettsville, TN 37072  
 Contractor: Josh King Excavation

Plant: Beaver Dam, KY  
 1/8/2026 9:01:29 AM

Tech: K. Cardwell  
 PC: J. Jarvis



**Structure ID: A2.3**

**P2 MH048LD07-28SQ**

**MH FLAT TOP w/28"x28" Hole F/F**

- P3) 28" x 28" - CASTING HEIGHT - 7.50"
- P2) 48" - MH FLAT TOP w/28"x28" Hole F/F - 7"
- P1) 48" - MH BASE Custom Ht F/n - 35"
- 1) CASTING - JBS 3300 SET (F/G/H)
- 1) 48" - Conseal CS-102 1.00"
- 1) 28" x 28" - Conseal CS-102 1.00"
- 2) Hole - 26

	0 lb
	1091 lb
	3309 lb
	500 lb
	0 lb
	0 lb
	0 lb
Structure Total:	4900 lb

- Structure Notes:
1. PER ASTM C-478 SPECS
  2. CONCRETE: 4,000 PSI AT 28 DAYS
  3. REINFORCEMENT: #4 BAR @ 10" C.C. E.W. (GRADE 60) - 2" MIN. REBAR CLEARANCE (TYP)
  4. NO STEPS
  5. JBS 3300 FRAME, GRATE, & CURB HOOD SUPPLIED BY ICAST
  6. LIFTERS: 4 EA. WRA016 CONAC WIRE ROPE ANCHORS FOR PLANT & FIELD HANDLING

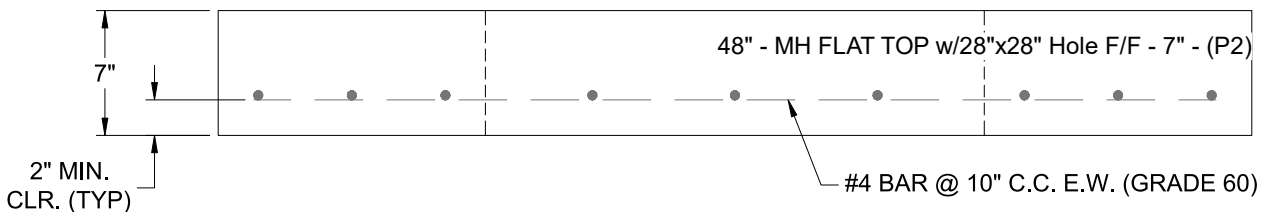
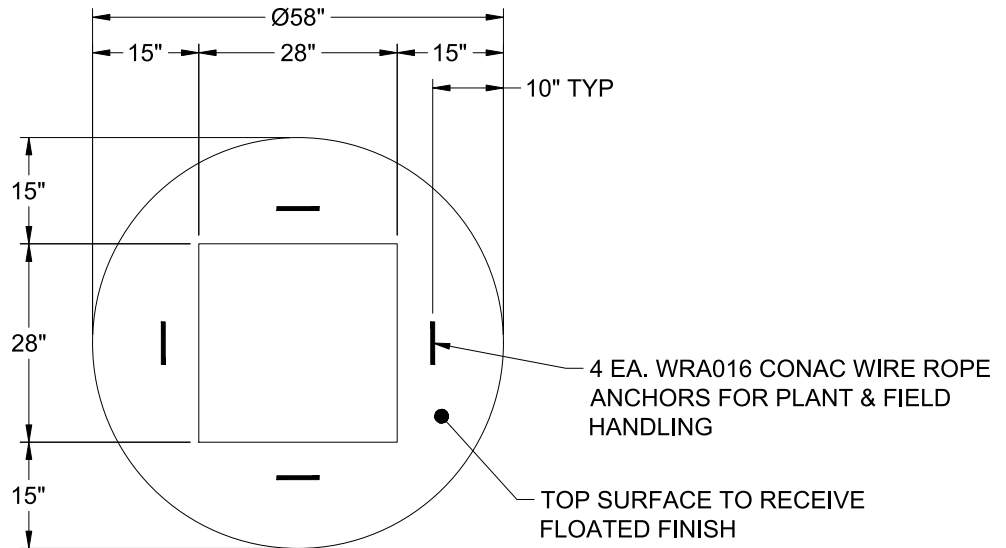

Coating (Int): Coating (Ext):	Seam Up: Flat Seam Dn: Flat	Wall Thickness: 5"	Height (Ext): 7"	Weight (Net): 1091 lb Volume (Net): 0.28cu.yd
----------------------------------	--------------------------------	--------------------	------------------	--