

GENERAL NOTES:

1. MANUFACTURED TO ASTM C-1577-16
2. LOAD REQUIREMENTS: PER AASHTO HL-93
3. REINFORCEMENT PER ASTM C-1577-16 (GRADE 60)
4. COVER DEPTH: 0'-0"
5. CONCRETE: 5,000 PSI AT 28 DAYS
6. JOINT SEALANT: 1" BUTYL MASTIC (CS-102)
EXTERIOR JOINT WRAP: 12" WIDE (CS-212)
7. WEIGHT: 3' X 3' RCBC = 999 LBS / LF
(60" LONG SECTION = 4,994 LBS EA.)
8. GRATING SUPPLIED BY OTHERS

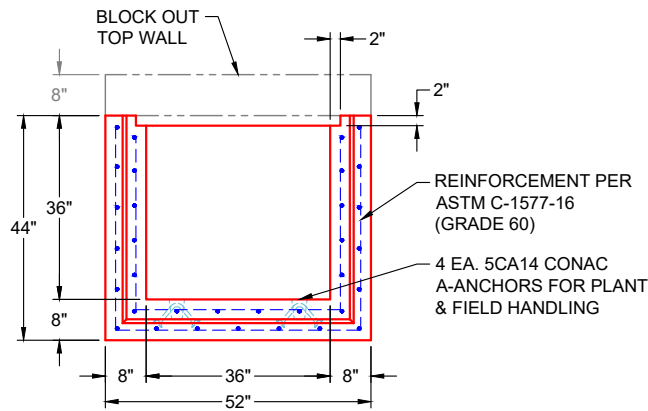

END VIEW
TYPICAL

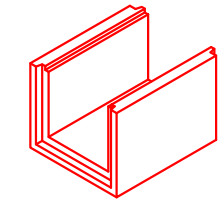
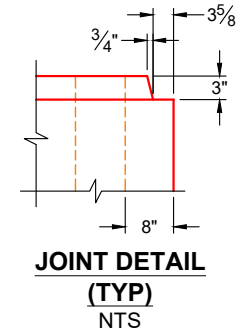

COMPONENT
ISOMETRIC VIEW
NTS

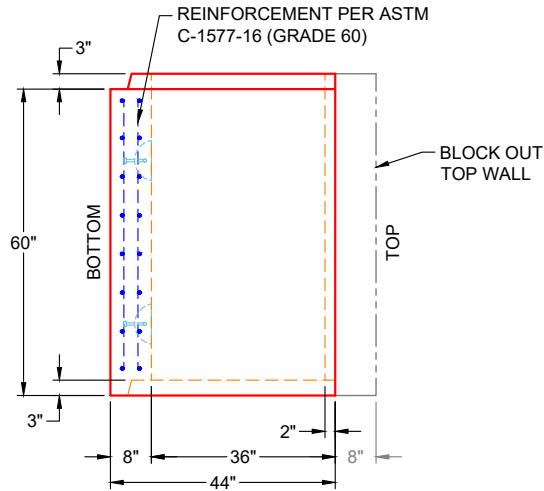

VIEW A
PC 3
(UPRIGHT IN MOLD)

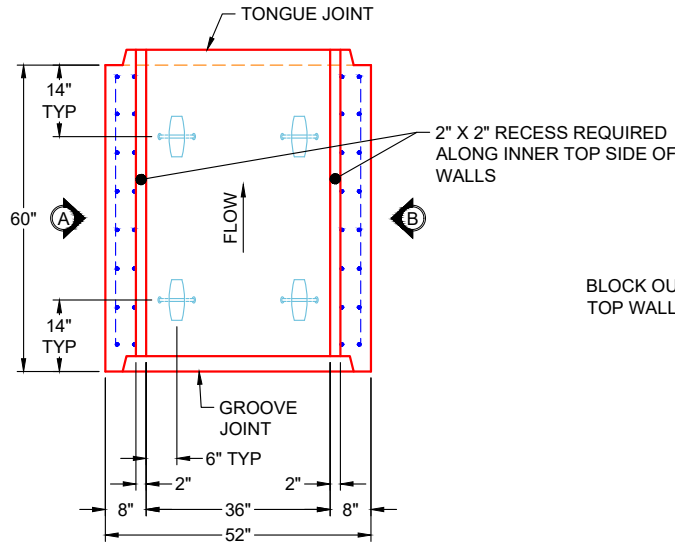

PLAN VIEW
PC 3
(UPRIGHT IN MOLD)

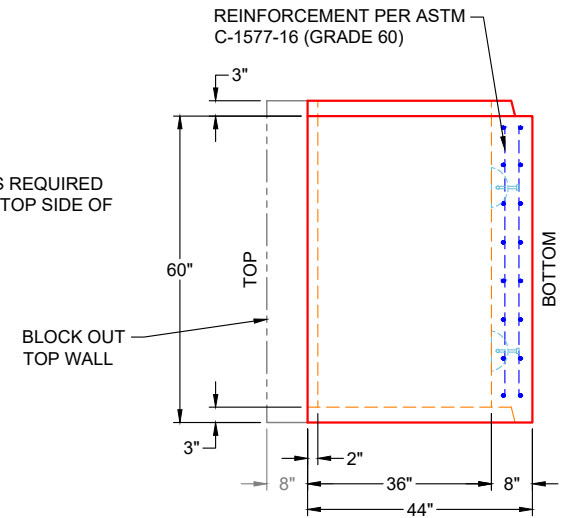

VIEW B
PC 3
(UPRIGHT IN MOLD)

PRODUCTION WORK ORDER

PRODUCT I.D.: BC036036-08WLF

DESCRIPTION: 36" X 36" X 60" BOX CULVERT (8" WALLS & NO HAUNCH)



QUALITY CONTROL CHECKLIST

- ALL DIMENSIONS CORRECT.
- LIFTERS INSTALLED INSIDE.
- RECESS WITH HAUNCHES CORRECT.
- REINFORCING CORRECT.
- SURFACE QUALITY ACCEPTABLE.
- LIFTERS INSTALLED OUTSIDE.
- PRODUCT SQUARE.

PRODUCT VIEW: RIGHT SIDE UP

CUSTOMER: MAC CONSTRUCTION & EXCAVATING, INC.

PLANT: BEAVER DAM, KY

PROJECT: 860 PZ LANDIS RIDGE 3 MG TANK

WEIGHT: 4,994 LBS (EA.)

STRUCTURE: 3 X 3 BC PIECE 3

TOP SECTION JOINT: TONGUE

ORDER NO: 25-1718

BASE SECTION JOINT: GROOVE

PE: J.H. ROSS

DRAWING: K. CARDWELL

QC CHECK INITIALS:

DATE: 01/19/26

SCALE: NTS

PG. 1 OF 1