

**PLAN VIEW**

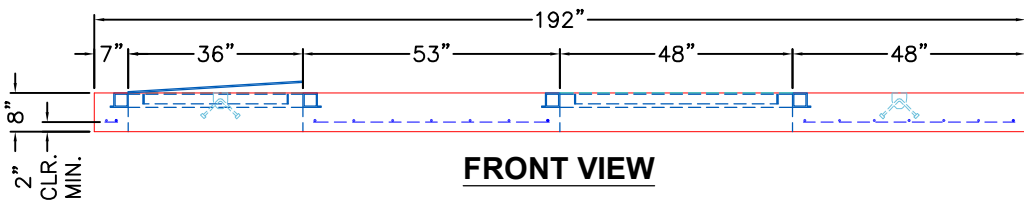

**FRONT VIEW**

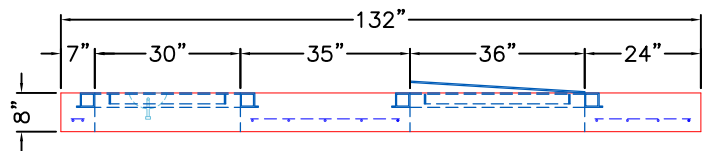

**RIGHT VIEW**

**GENERAL NOTES:**

1. MANUFACTURED TO ASTM C-913 (LATEST REVISION).
2. CONCRETE: 5,000 PSI AT 28 DAYS.
3. REINFORCING: SEE REINFORCEMENT DESIGN PROVIDED BY MATT CHILDS ENGINEERING PER ASTM A615 (GRADE 60).
4. WEIGHT: 13,968 LBS
5. HALLIDAY 36" X 30" H1W HATCH AND 2X HALLIDAY 36" X 48" H1W HATCHES PROVIDED BY ICAST.
6. HATCHES TO BE CAST IN TOP SLAB.

		<b>PRODUCTION WORK ORDER</b> QUALITY CONTROL CHECKLIST <input type="checkbox"/> ALL DIMENSIONS CORRECT. <input type="checkbox"/> LIFTERS INSTALLED. <input type="checkbox"/> HATCHES CORRECT LOCATION. <input type="checkbox"/> REINFORCING CORRECT. <input type="checkbox"/> SURFACE QUALITY ACCEPTABLE. <input type="checkbox"/> EDGES CHAMFERED. <input type="checkbox"/> ALL PATCHWORK ACCEPTABLE.	PRODUCT I.D.: CTS PRODUCT VIEW: RIGHT SIDE UP PLANT: BEAVER DAM, KY. WEIGHT: 13,968 LBS. TOP SECTION JOINT: N/A BASE SECTION JOINT: N/A QC CHECK INITIALS:	DESCRIPTION: 132" X 192" TOP SLAB FOR 120" X 180" VAULT CUSTOMER: CLEARLY CONSTRUCTION PROJECT: WCWD FLOW FOR OUR FUTURE METER VAULTS STRUCTURE: WATER MAIN MASTER METER VAULT ORDER NO: 25-1706 PE: C. GOFF DATE: 10/2/25	DRAWING: J. COPPAGE SCALE: NTS PG. 1 of 1
---	--	--	--	--	---

**DESIGN NOTE:**

HS20 LOADING (OFF-STREET) - ASTM C857  
 CONCRETE 28 DAY COMPRESSIVE STRENGTH - 5000 PSI  
 REINFORCEMENT STEEL - 60,000 PSI  
 REBAR MIN SPLICE LENGTHS: #4-22" #5-28" #6-33"  
 PLACE 4-#4 BAR DIAGONAL AROUND OPENING(S)

# 25-1706 WATER MAIN MASTER METER VAULT

## REINFORCING STEEL SCHEDULE

MARK	NO.	LENGTH	TYPE	lb/EA.	TOTAL LB	BENDING DIAGRAM
6A	27	10'-9"	STR.	16,1465	435,9555	
6B	17	15'-9"	STR.	23,6565	402,1605	
5C	25	28'-7" (2)	BENT	29,8124	1490,6200	
5D	104	11'-7"	BENT	12,0814	1258,4656	
5E	36	10'-10"	STR.	11,2992	406,7712	
5F	14	15'-10"	STR.	16,5142	231,1988	

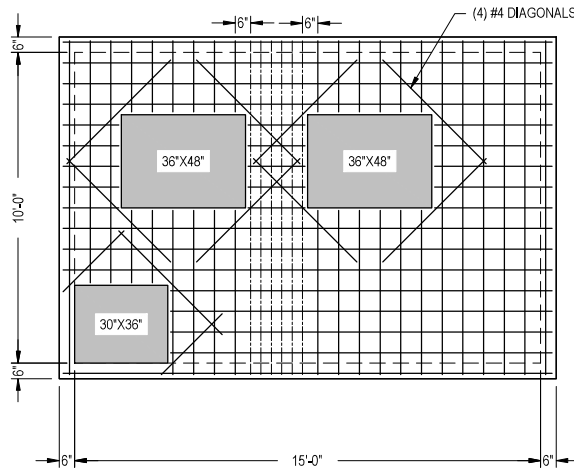

**PLAN VIEW**  
(TOP SLAB)

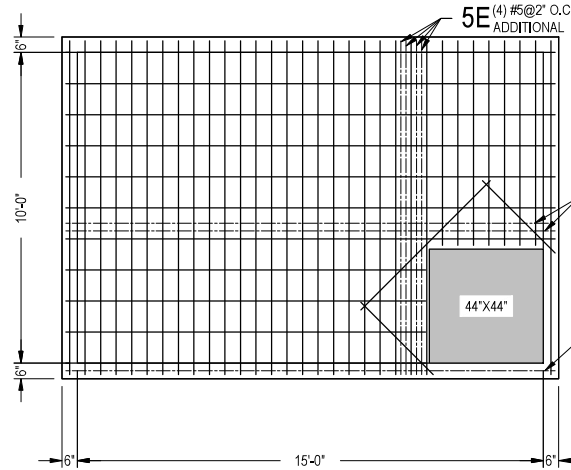

**PLAN VIEW**  
(BASE SECTION - TOP MAT)

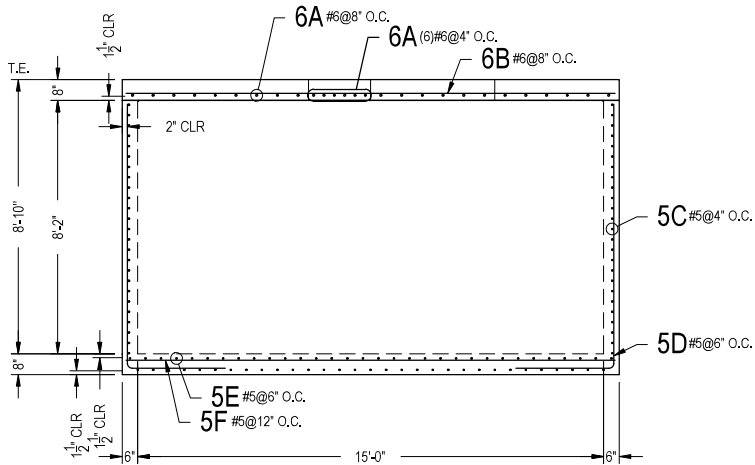

**FRONT VIEW**

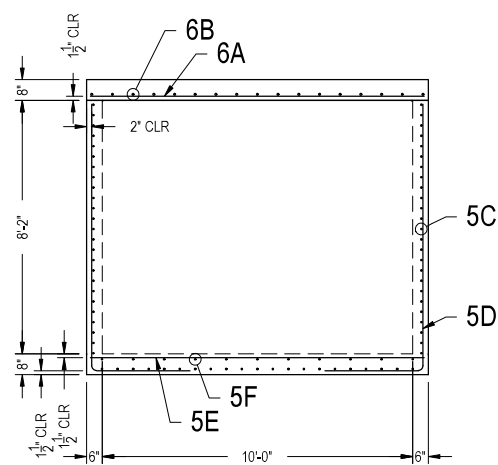

**RIGHT VIEW**

**WATER MAIN MASTER  
METER VAULT**



MATT CHILDS ENGINEERING P.L.L.C.  
 515 E. INTERSTATE 30, #1017  
 ROCKWALL, TX 75087

REVISIONS  
 DRAWN BY: MBJ  
 SCALE: 1/4" = 1'  
 DATE: 6/20/2025  
 METER VAULTS  
 10'-0" x 15'-0"  
 CLEAR CONSTRUCTION  
 W/WD FLOW FOR FUTURE  
 11"x17"  
 PAGE: 1 OF 1