

Job Name: 25-1684P8 KYTC Jefferson Co. Call 200 (251007)
Job Location: I-264 Louisville, KY
Contractor: Cleary Construction, Inc.

PC: J. Jarvis
 TECH: N. Richards
 Plant: Beaver Dam, Ky.



Structure ID: 5111+07 MBI B1

Spec: KYTC
 Type: MBI TYPE 9
 Size: 60" x 60"

Rim: 579.4'
 Invert: 570'
 Rim to Invert: 9.4'

Sump: 0"
 Floor (Top): 570'
 Floor Height: 8"

Floor (Bot): 569.333'
 Overall Height: 9.75'
 Slack: 3.8"

Structure Notes:

- KYTC STATE PROJECT 251007
- REINFORCING: #5 BAR @ 12" C/C E.W. (TYP.)
- CASTING FRAMES & GRATES BY OTHERS.
- CS-102 BUTYL REQUIRED (SUPPLIED BY ICAST).
- KYTC CERTIFICATIONS REQUIRED.
- USE THIS WORK ORDER FOR POURING RISER WALLS ONTO FLOOR WITH WET STICK REBAR-PAGE 2 OF 2.

STRUCTURE SUMMARY:

P4) 24" x 120" - CB MED BAR BOX INLET 9B1 RH F/F - 17"	4000 lb
P3) 24" x 36" - BOX RISER 8inW F/F - 24"	2343 lb
P2) 60" x 60" - CB FT REDUCER 24"X36" HOLE-FT F/F - 8"	3297 lb
P1) 60" x 60" - BOX BASE 8inW, 8inF F/n - 60"	12383 lb
1) 60" x 60" - Conseal CS-102 1.00"	0 lb
2) 24" x 36" - Conseal CS-102 1.00"	0 lb
1) 24" x 120" - Conseal CS-102 1.00"	0 lb
2) Hole - 40	0 lb
1) Hole - 28	0 lb
2) Hole - 10	0 lb
Structure Total:	22024 lb

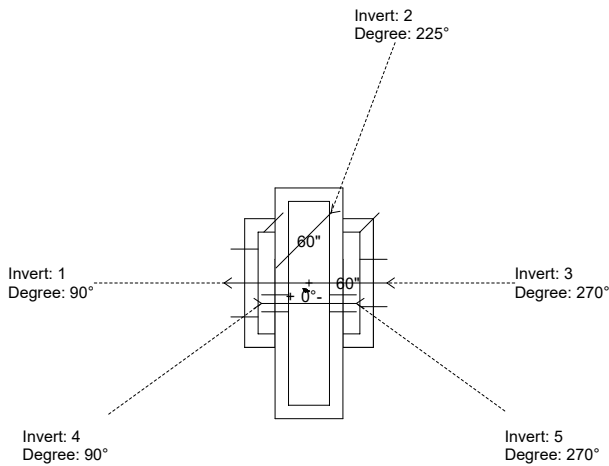

Position	Elev	Angle	Pipe	Pipe OD	Hole	Connector	Up (")	Ref
Rim	579.4'							
Reducer	575'							
Invert 1	570'	90°	36" CMP	37"	40"	Hole 40	-2"	P1
Invert 2	570'	225°	30" RCP B WALL	37"	40"	Hole 40	-5"	P1
Invert 3	570'	270°	24" CMP	25"	28"	Hole 28	-2"	P1
Invert 4	576.67'	90°	6" HDPE	6.9"	10"	Hole 10	10"	P3
Invert 5	576.67'	270°	6" HDPE	6.9"	10"	Hole 10	10"	P3
Invert 6								
Invert 7								
Invert 8								

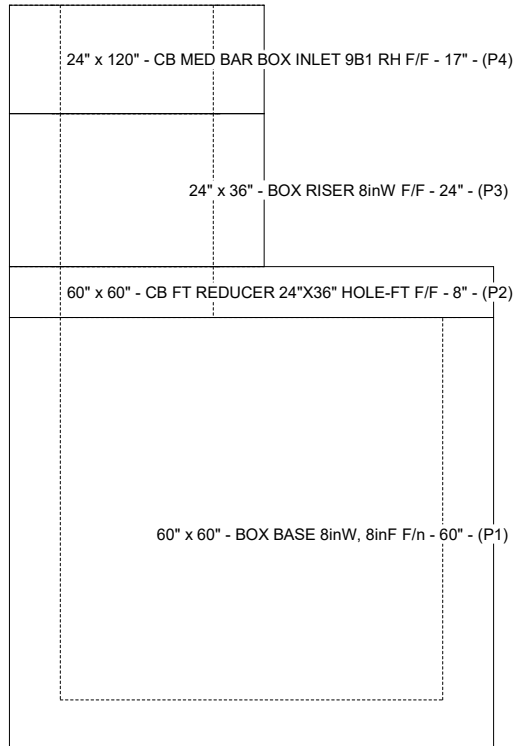

Cast (Int. Dim.) - Interior Dimensions

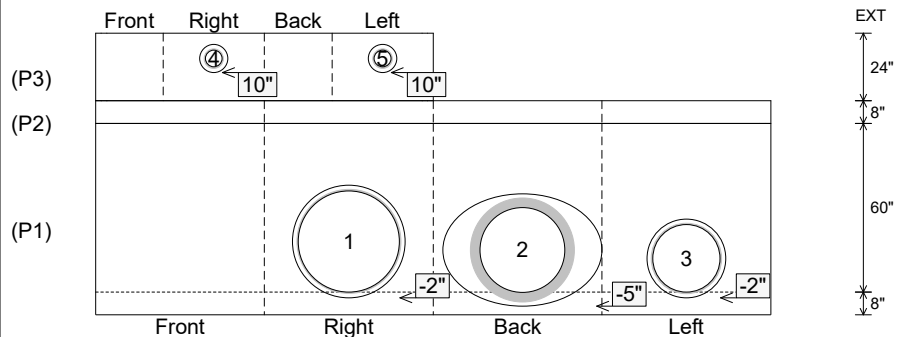

Submittal Drawing
 4/14/2026 3:06:52 PM

SUBMITTAL
 APPROVED BY: