

Job Name: 25-1684P7 KYTC Jefferson Co. Call 200 (251007)
 Job Location: I-264 Louisville, Ky.
 Contractor: Cleary Construction, Inc.

Plant: Beaver Dam, Ky.
 3/19/2026 1:03:59 PM

Tech: J. Coppage
 PC: J. Jarvis



Structure ID: 127+10 LT CBIA INLET 31A

P1 BX2436-08BA36

BOX BASE 8inW, 8inF

- P3) 24" x 120" - CB INLET KY A 10' TOP RIGHT - 10"
- P2) 24" x 120" - CB INLET KY A 10' BOTTOM RIGHT - 18"
- P1) 24" x 36" - BOX BASE 8inW, 8inF - 36"
- 1) 24" x 36" - Conseal CS-102 1.00"
- 2) Hole - 18"

3398 lb
 5270 lb
 4728 lb
 0 lb
 0 lb

Structure Notes:
 -KYTC STATE PROJECT 251007
 -REINFORCING: #5 BAR @ 12" C/C E.W. (TYP.)
 -CS-102 BUTYL REQUIRED (SUPPLIED BY ICAST).
 -KYTC CERTIFICATIONS REQUIRED.

Structure Total: 13396 lb

Rim: 591.59' Rim to Invert: 5.63' Slack: 3.56" Sump: 0" Step Position:

Position	Elev	Angle	Ext. (cw)	Pipe	Pipe OD	Connector	Hole	Horz Size	Up ()	Offset
Invert 1	585.96'	0°	20"	15" CMP	16"	Hole 18	18"	18"	-1.5"	0"
Invert 2	585.96'	180°	20"	15" CMP	16"	Hole 18	18"	18"	-1.5"	0"
Invert 3										
Invert 4										
Invert 5										
Invert 6										
Invert 7										
Invert 8										

RIGHT-SIDE UP VIEW (int. dimensions)

UPSIDE-DOWN VIEW (int. dimensions)

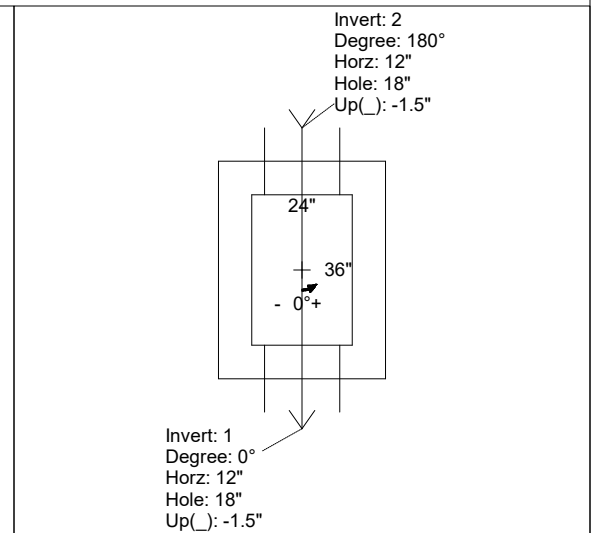
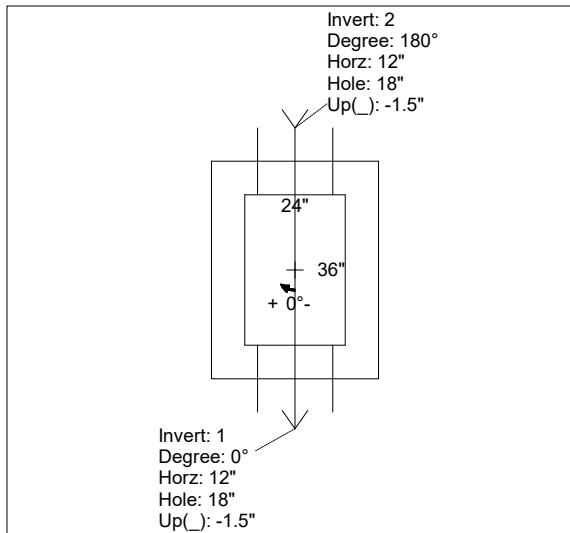
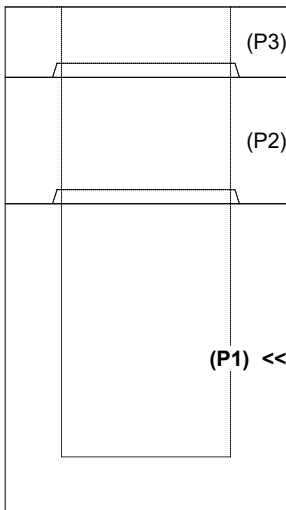

INSIDE WALL DIMENSIONS

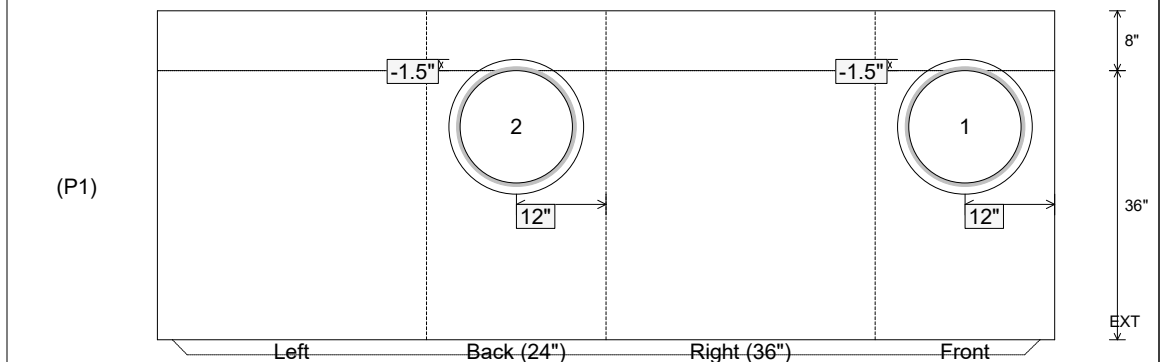

Coating (Int):
 Coating (Ext):

Seam Up: Tongue
 Seam Dn: n/a

Wall Thickness: 8"
 Floor Height: 8"

Height (Int): 36"
 Height (Ext): 44"

Weight (Net): 4728 lb
 Volume (Net): 1.21cu.yd