

KYTC STATE PRODUCT

REINFORCING CUT LIST

BAR	QTY.	MATERIAL	LENGTH	SHAPE	TOTAL WEIGHT
(A)	3	#5 BAR	34"	STR.	9 LBS.
(B)	2	#5 BAR	48"	STR.	8 LBS.
(C)	3	#5 BAR	132"	STR.	34 LBS.
(D)	7	#5 "L" BAR	30"	BENT	44 LBS.
(E)	8	#5 "U" BAR	42"	BENT	30 LBS.
(F)	5	#5 BAR	100"	STR.	44 LBS.
(G)	8	#5 BAR	12"	STR.	8 LBS.

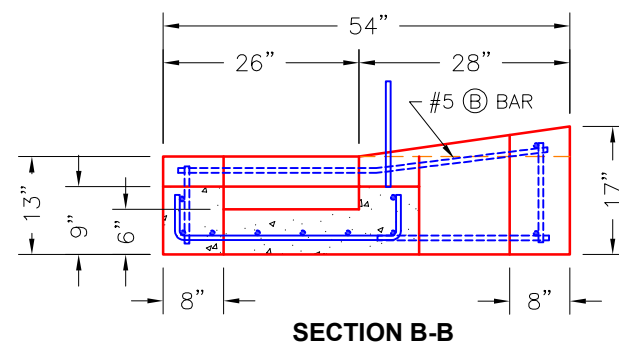
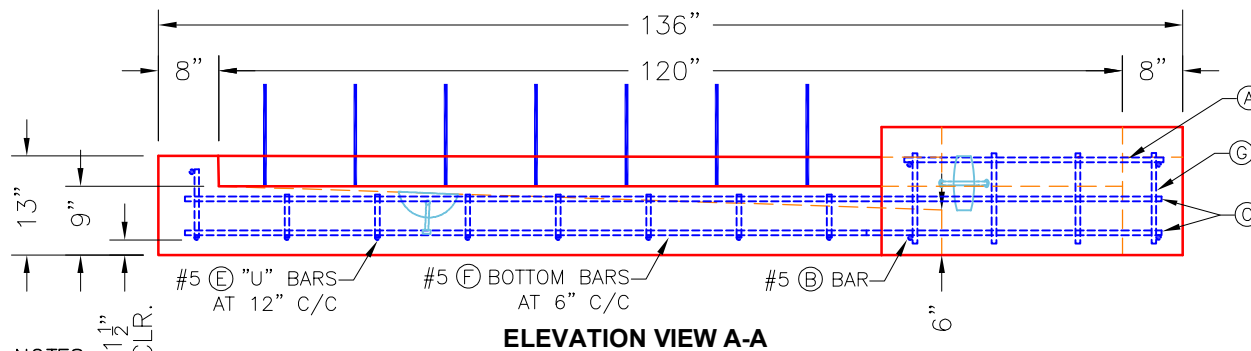
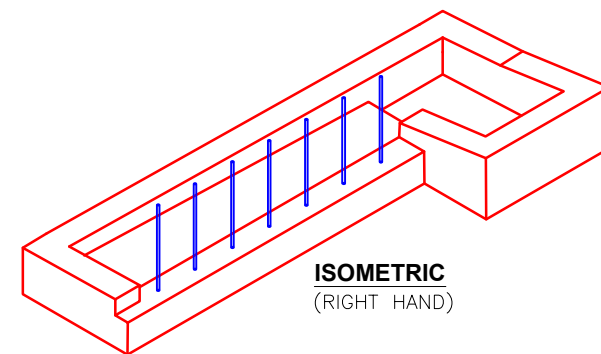
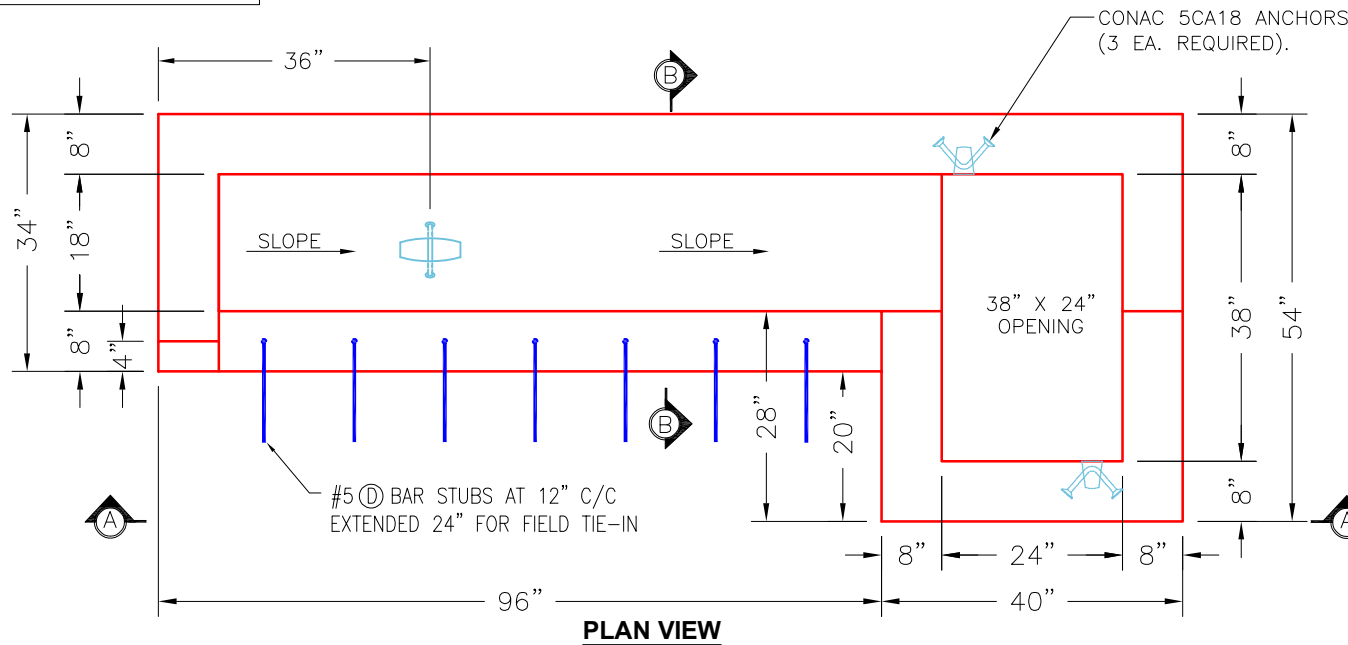

SECTION B-B

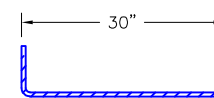

#5 (E) BENT "U" BAR

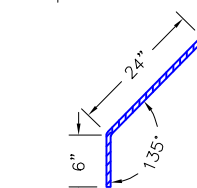

#5 (D) BENT BAR STUB

NOTES:

1. CONCRETE: 4,500 PSI KYTC APPROVED.
2. REINFORCING: #5 BAR-SEE CHART (GRADE 60)
3. REINFORCING BARS TO BE TACK WELDED OR TIED.
4. LIFTING ANCHOR POCKETS TO BE GROUTED AFTER SETTING BY CONTRACTOR.
5. DRAWING TO BE USED IN CONJUNCTION WITH KYTC STD. DRAWINGS RDB-230-09, RDB-231-11, RDB-240-02, AND THE STANDARD SPECIFICATIONS FOR ROAD AND BRIDGE CONSTRUCTION.
6. TOP PHASE CAN BE SUPPLIED AS RIGHT HAND, LEFT HAND & SAG. "A" DESIGNATES SAG & "B" DESIGNATES GRADE CONDITION. "1" DESIGNATES REBAR STUBS ON ONE SIDE AND "2" DESIGNATES REBAR STUBS ON BOTH SIDES AS SHOWN.

PRODUCTION WORK ORDER

PRODUCT I.D.: CMBBIT9-B1RH

DESCRIPTION: KYTC MBI B1 TYPE 9 10' TOP PHASE (RIGHT HAND)

QUALITY CONTROL CHECKLIST

- ALL DIMENSIONS CORRECT.
- LIFTERS INSTALLED.
- CASTING AT CORRECT LOCATION.
- REINFORCING CORRECT.
- LIGHT BRUSH FINISH ACCEPTABLE.
- KYTC STANDARD THROAT CORRECT.
- ALL PATCHWORK ACCEPTABLE.

PRODUCT VIEW: RIGHT SIDE UP

CUSTOMER: CLEARY CONSTRUCTION INC.

PLANT: BEAVER DAM, KY.

PROJECT: JEFFERSON CO. (251007)

WEIGHT: 4,325 LBS.

STRUCTURE ID.: 5077+33 RT MBI B1 (SEC. P2)

TOP SECTION JOINT: N/A

SALES ORDER NO.: 25-1684

BOTTOM SECTION JOINT: SHIP-LAP GROOVE

PC: J. JARVIS

DRAWING: N. RICHARDS

QC CHECK INITIALS:

DATE: 11/19/25

SCALE: NTS

PG. 1 of 1

