

KYTC STATE PRODUCT

REINFORCING CUT LIST

| BAR | QTY. | MATERIAL | LENGTH | SHAPE | TOTAL WEIGHT |
|-----|------|------------|--------|-------|--------------|
| (A) | 3 | #5 BAR | 34" | STR. | 9 LBS. |
| (B) | 2 | #5 BAR | 48" | STR. | 8 LBS. |
| (C) | 3 | #5 BAR | 132" | STR. | 34 LBS. |
| (D) | 7 | #5 "L" BAR | 30" | BENT | 44 LBS. |
| (E) | 8 | #5 "U" BAR | 42" | BENT | 30 LBS. |
| (F) | 5 | #5 BAR | 100" | STR. | 44 LBS. |
| (G) | 8 | #5 BAR | 12" | STR. | 8 LBS. |

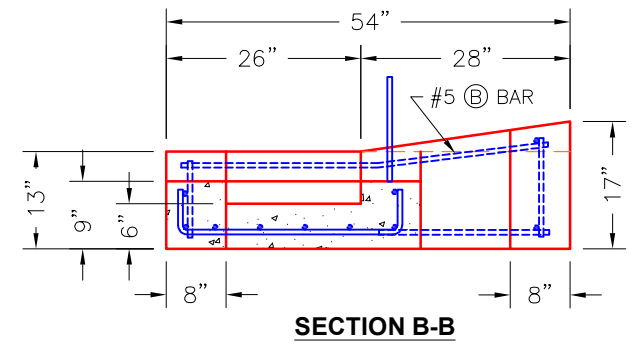
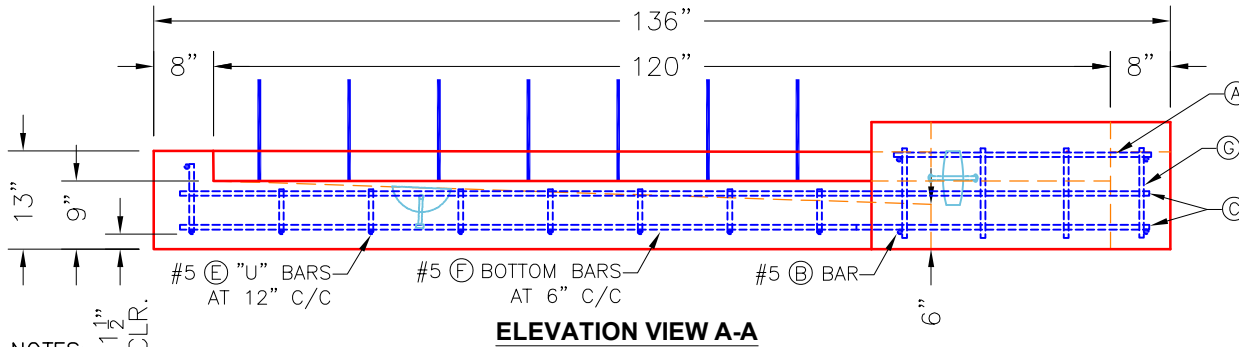
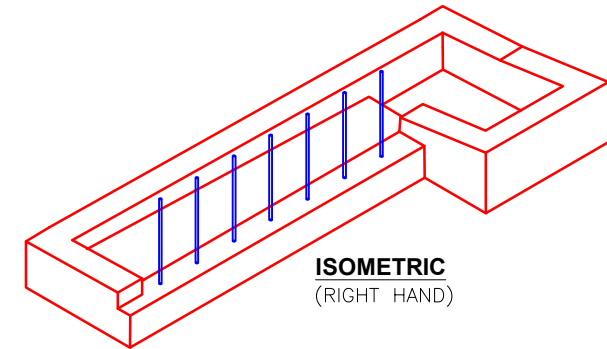
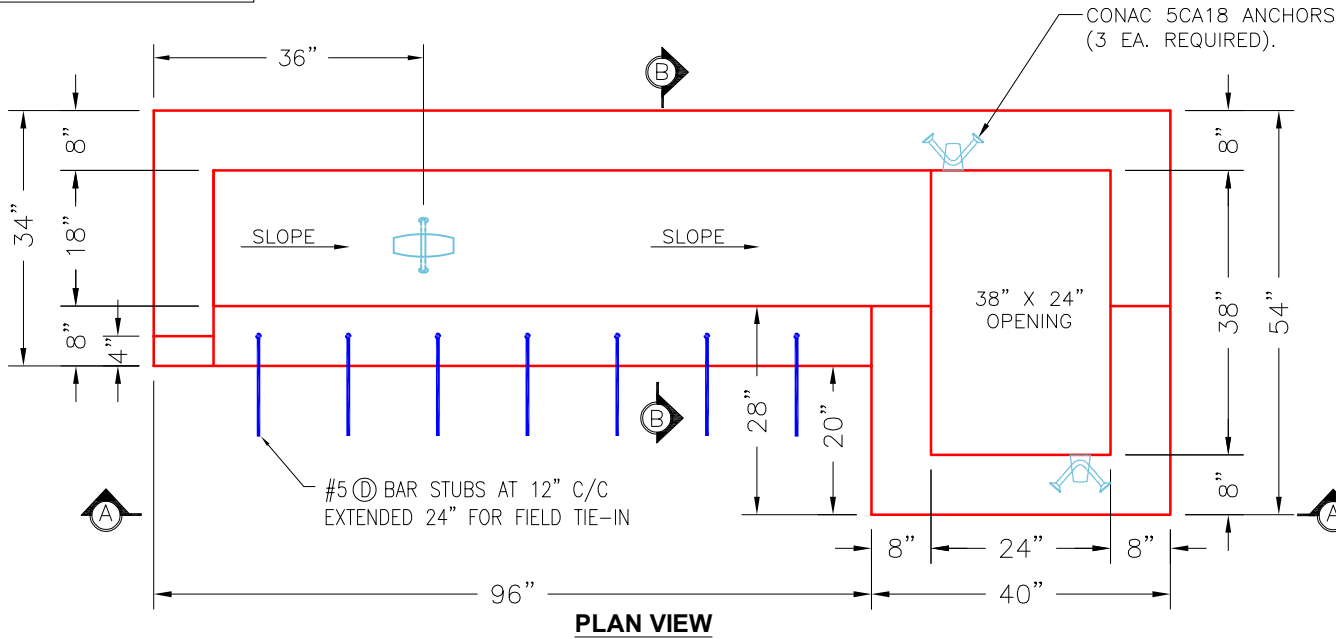

~NOTES:

1. CONCRETE: 4,500 PSI KYTC APPROVED.
2. REINFORCING: #5 BAR-SEE CHART (GRADE 60)
3. REINFORCING BARS TO BE TACK WELDED OR TIED.
4. LIFTING ANCHOR POCKETS TO BE GROUTED AFTER SETTING BY CONTRACTOR.
5. DRAWING TO BE USED IN CONJUNCTION WITH KYTC STD. DRAWINGS RDB-230-09, RDB-231-11, RDB-240-02, AND THE STANDARD SPECIFICATIONS FOR ROAD AND BRIDGE CONSTRUCTION.
6. TOP PHASE CAN BE SUPPLIED AS RIGHT HAND, LEFT HAND & SAG. "A" DESIGNATES SAG & "B" DESIGNATES GRADE CONDITION. "1" DESIGNATES REBAR STUBS ON ONE SIDE AND "2" DESIGNATES REBAR STUBS ON BOTH SIDES AS SHOWN.

| PRODUCTION WORK ORDER | | PRODUCT I.D.: CMBBIT9-B1RH | DESCRIPTION: KYTC MBI B1 TYPE 9 10' TOP PHASE (RIGHT HAND) | |
|-----------------------|--|---------------------------------------|--|----------------------|
| | QUALITY CONTROL CHECKLIST | PRODUCT VIEW: RIGHT SIDE UP | CUSTOMER: CLEARY CONSTRUCTION INC. | |
| | <input type="checkbox"/> ALL DIMENSIONS CORRECT. <input type="checkbox"/> LIFTERS INSTALLED. <input type="checkbox"/> CASTING AT CORRECT LOCATION. <input type="checkbox"/> REINFORCING CORRECT. <input type="checkbox"/> LIGHT BRUSH FINISH ACCEPTABLE. <input type="checkbox"/> KYTC STANDARD THROAT CORRECT. <input type="checkbox"/> ALL PATCHWORK ACCEPTABLE. | PLANT: BEAVER DAM, KY. | PROJECT: JEFFERSON CO. (251007) | |
| | | WEIGHT: 4,325 LBS. | STRUCTURE ID.: 4016+28 LT MBI B1 (SEC. P2) | |
| | | TOP SECTION JOINT: N/A | SALES ORDER NO.: 25-1684 | |
| | | BOTTOM SECTION JOINT: SHIP-LAP GROOVE | PC: J. JARVIS | DRAWING: N. RICHARDS |
| | | QC CHECK INITIALS: | DATE: 11/19/25 | SCALE: NTS |