

Job Name: 25-1675 - Campbellsville Middle School Ph 2  
 Job Location: Campbellsville, KY 72718  
 Contractor: Rising Sun Development Company

Plant: Beaver Dam, KY

Tech: J. Coppage

4/23/2026 3:20:39 PM

PC: J. Jarvis



**Structure ID: 8**

**P4 GR3**

**GRADE RING F/F**

- P5) 24" - CASTING HEIGHT - 7"
- P4) 24" - GRADE RING F/F - 3"
- P3) 60" - MH FLAT TOP w/ 24" ECC Hole F/G - 13"
- P2) 60" - MH RISER T/G - 24"
- P1) 60" - MH BASE T/n - 54"
- 1) CASTING - HOE MCB-315-B Fr./Bar Grate
- 2) 60" - Conseal CS-102 1.00"
- 2) Hole - 38
- 6) MH Step ML-10-TDS-NCR - 10"

0 lb  
 202 lb  
 2869 lb  
 2505 lb  
 7151 lb  
 255 lb  
 0 lb  
 0 lb  
 0 lb  
 -----  
 Structure Total: 12982 lb

Structure Notes:

1. PER ASTM C-478 SPECIFICATIONS
2. CONCRETE: 4,500 PSI AT 28 DAYS
3. REINFORCEMENT: (1) #3 HOOP CENTERED (GRADE 60)

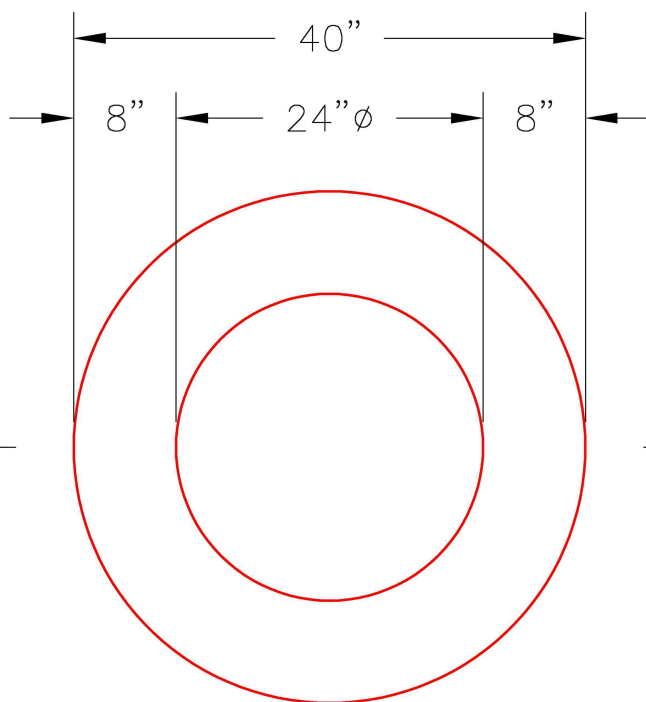

**PLAN VIEW**

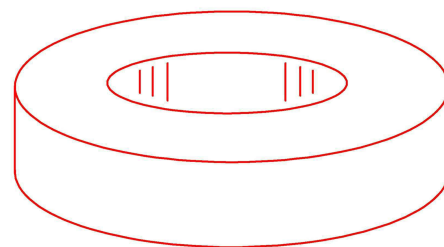

**ISOMETRIC VIEW**

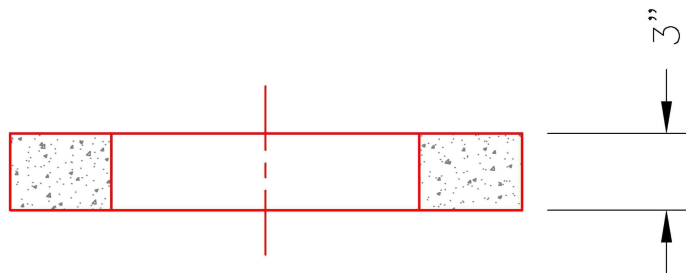

**SECTION A-A**

Coating (Int):  
 Coating (Ext):

Seam Up: Flat  
 Seam Dn: Flat

Wall Thickness: 8"

Height (Ext): 3"

Weight (Net): 202 lb  
 Volume (Net): 0.05cu.yd