

Job Name: 25-1670 Closplint Cluster Sewer System
 Job Location: Baxter, KY
 Contractor: Highland Services

Plant: Beaver Dam
 11/17/2025 9:14:24 AM

Tech: J. Coppage
 PC: T. Ryan



Structure ID: 7000 GAL SEPTIC TANK

P2 CTS

CB FLAT TOP 6"W w/(2) 24" HOLES

- P2) 108" x 192" - CB FLAT TOP 6"W w/(2) 18" HOLES - 8"
- P1) 108" x 192" - BOX BASE 6inW, 6inF, Variable Ht - 96"
- 1) JOINT WRAP - 0.065"x6"x50' CONSEAL CS212
- 1) JOINT WRAP PRIMER - CONSEAL CS-75 (1 gal.)
- 1) SECONDARY POUR
- 1) ASSEMBLY REQUIRED
- 2) PSX - 12-06 NYLO

16091 lb
 42371 lb
 0 lb
 0 lb
 0 lb
 0 lb
 16 lb

 Structure Total: 58478 lb

Structure Notes:

1. (CASTINGS PROVIDED BY OTHERS)
 2. PER ASTM C913 SPECIFICATIONS.
 3. CONCRETE = 4,500 PSI AT 28 DAYS.
 4. REINFORCING PER ASTM A615 (GRADE 60).
- TOP SLAB:
 (As .62) #5 BARS AT 6" C.C.E.W.
- RISER/WALLS:
 HORIZONTALS (As .68) #6 BARS AT 6" C.C.
 VERTICALS (As .14) #4 BARS AT 12" C.C.
- FLOOR
 LONG BAR (As .48) #5 BARS AT 8" C.C.
 SHORT BAR (As .36) #5 BARS AT 10" C.C.

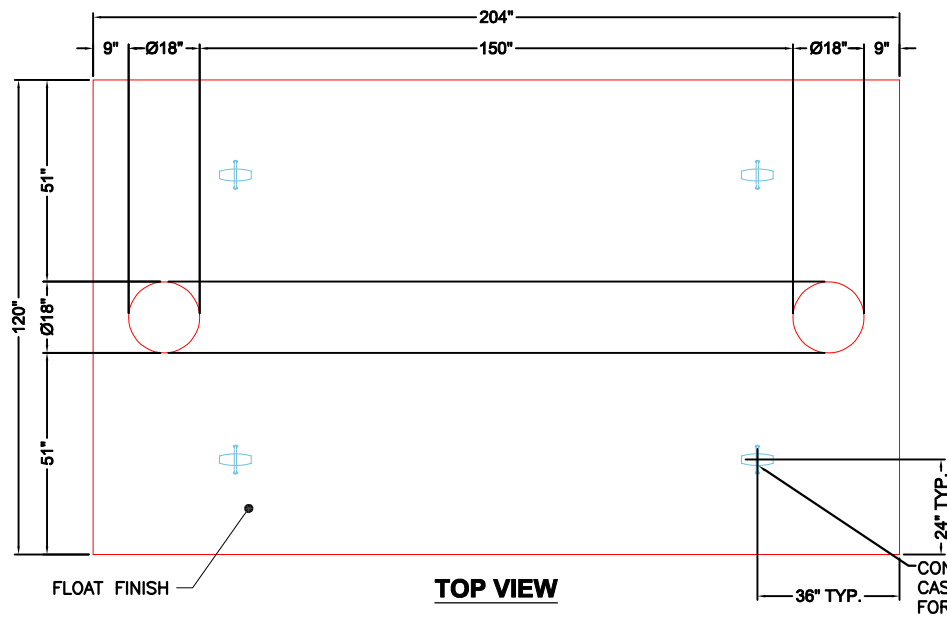

GENERAL NOTES:

1. MANUFACTURED TO ASTM C-913 (LATEST REVISION).
2. CONCRETE: 4,500 PSI AT 28 DAYS.
3. REINFORCING: #5 BAR @ 6" C-C E.W. PER ASTM A615 (GRADE 60).
4. WEIGHT: 16,092 LBS
 CASTINGS: PROVIDED BY OTHERS.

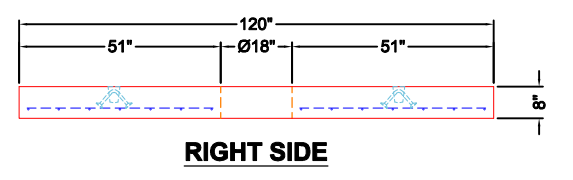
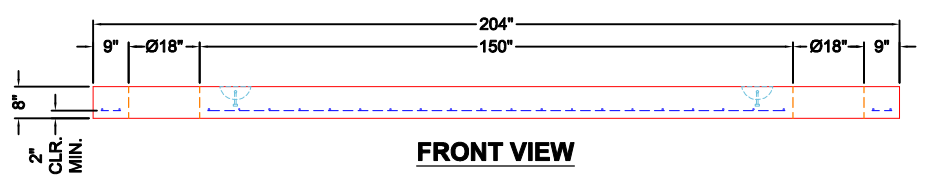

CONAC 5CA14 ANCHORS
 CAST IN EACH SECTION AS SHOWN
 FOR PLANT & FIELD HANDLING.

Coating (Int): Coating (Ext):	Seam Up: Flat Seam Dn: Flat	Wall Thickness: 6"	Height (Ext): 8"	Weight (Net): 16092 lb Volume (Net): 4.11cu.yd
----------------------------------	--------------------------------	--------------------	------------------	---