

Job Name: 25-1664 Springfield WWTP  
 Job Location: Springfield, TN  
 Contractor: Smith Contractors, Inc.

Plant: Beaver Dam  
 2/2/2026 12:06:32 PM

Tech: J. Coppage  
 PC: C. Goff



**Structure ID: SULPHUR-SSMH-2 5+18.88**

**P5 MH048CN36X**

**ECC XYPEX CONE w/ 24" HOLE**

P6)	24" - CASTING HEIGHT - 6"	0 lb
P5)	48" - ECC XYPEX CONE w/ 24" HOLE - 36"	2251 lb
P4)	48" - MH RISER w/XYPEX - 72"	5030 lb
P3)	48" - MH RISER w/XYPEX - 72"	5030 lb
P2)	72" - XYPEX MH FT REDUCER 48" HOLE - 15"	3864 lb
P1)	72" - MH BASE Custom Ht, w/XYPEX - 76"	13736 lb
1)	JOINT WRAP - 0.065"x6"x50' CONSEAL CS212	0 lb
1)	JOINT WRAP PRIMER - CONSEAL CS-75 (1 gal.)	0 lb
1)	72" - MH INVERT CHANNEL w/XYPEX - FULL HEIGHT	5422 lb
1)	72" - Conseal CS-102 1.00" (Double)	0 lb
3)	48" - Conseal CS-102 1.00" (Double)	0 lb
2)	Kor-N-Seal2 - S206-36	13 lb
	446.38 SqFt) MASTERSEAL 610 - Two Coats [EXT]	0 lb
	<b>Structure Total:</b>	<b>35346 lb</b>

Structure Notes:  
 1. JBS-1155 SANITARY BY ICAST.  
 2. PER ASTM C478 SPECIFICATIONS.  
 3. CONCRETE = 4,000 PSI AT 28 DAYS.  
 4. REINFORCING PER ASTM A615 (GRADE 60).  
 - CONE (As .12)  
 - TRANS. SLAB - AS SHOWN BY WINFORD PETRONE  
 - RISER/WALLS (As .12)  
 - FLOOR - AS SHOWN BY WINFORD PETRONE

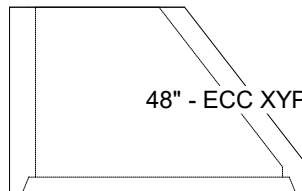
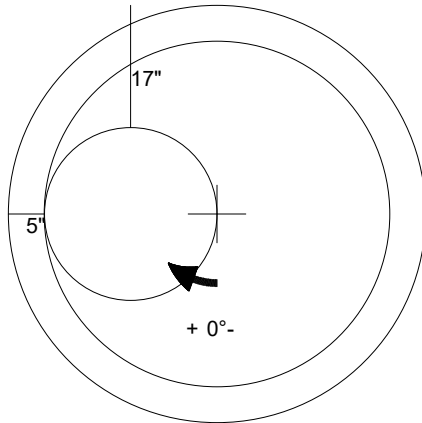

48" - ECC XYPEX CONE w/ 24" HOLE - 36" - (P5)

Coating (Int):  
 Coating (Ext): MASTERSEAL 610

Seam Up: Flat  
 Seam Dn: Groove

Wall Thickness: 5"

Height (Ext): 36"

Weight (Net): 2251 lb  
 Volume (Net): 0.57cu.yd