

Job Name: 25-1664 Springfield WWTP
 Job Location: Springfield, TN
 Contractor: Smith Contractors, Inc.

Plant: Beaver Dam

Tech: J. Coppage

2/2/2026 12:06:31 PM

PC: C. Goff



Structure ID: SULPHUR-SSMH-1 2+56.07

P4 MH048CN36X

ECC XYPEX CONE w/ 24" HOLE

P5)	24" - CASTING HEIGHT - 6"	0 lb
P4)	48" - ECC XYPEX CONE w/ 24" HOLE - 36"	2251 lb
P3)	48" - MH RISER w/XYPEX - 60"	4192 lb
P2)	72" - XYPEX MH FT REDUCER 48" HOLE - 15"	3864 lb
P1)	72" - MH BASE Custom Ht, w/XYPEX - 78"	14027 lb
1)	JOINT WRAP - 0.065"x6"x50' CONSEAL CS212	0 lb
1)	JOINT WRAP PRIMER - CONSEAL CS-75 (1 gal.)	0 lb
1)	72" - MH INVERT CHANNEL w/XYPEX - FULL HEIGHT	5422 lb
1)	72" - Conseal CS-102 1.00" (Double)	0 lb
2)	48" - Conseal CS-102 1.00" (Double)	0 lb
2)	Kor-N-Seal2 - S206-36	13 lb
	343.84 SqFt) MASTERSEAL 610 - Two Coats [EXT]	0 lb
	Structure Total:	29769 lb

Structure Notes:
 1. JBS-1155 SANITARY BY ICAST.
 2. PER ASTM C478 SPECIFICATIONS.
 3. CONCRETE = 4,000 PSI AT 28 DAYS.
 4. REINFORCING PER ASTM A615 (GRADE 60).
 - CONE (As .12)
 - TRANS. SLAB - AS SHOWN BY WINFORD PETRONE
 - RISER/WALLS (As .12)
 - FLOOR - AS SHOWN BY WINFORD PETRONE

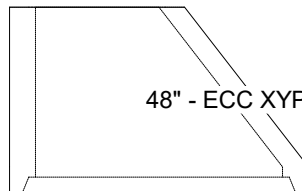
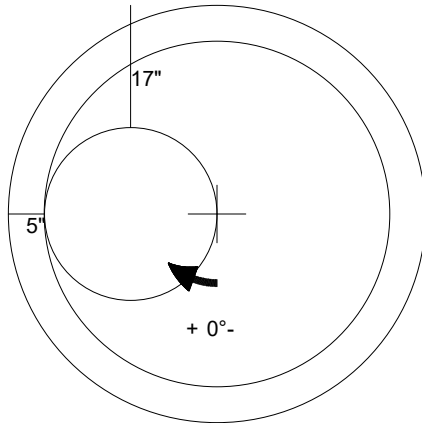

48" - ECC XYPEX CONE w/ 24" HOLE - 36" - (P4)

Coating (Int):
 Coating (Ext): MASTERSEAL 610

Seam Up: Flat
 Seam Dn: Groove

Wall Thickness: 5"

Height (Ext): 36"

Weight (Net): 2251 lb
 Volume (Net): 0.57cu.yd