

Job Name: 25-1664 Springfield WWTP
 Job Location: Springfield, TN
 Contractor: Smith Contractors, Inc.

Plant: Beaver Dam

Tech: J. Coppage

2/2/2026 12:06:30 PM

PC: C. Goff



Structure ID: SULPHUR-SSMH-1 2+56.07

P2 MH072TS15X

XYPEX MH FT REDUCER 48" HOLE

- P5) 24" - CASTING HEIGHT - 6"
- P4) 48" - ECC XYPEX CONE w/ 24" HOLE - 36"
- P3) 48" - MH RISER w/XYPEX - 60"
- P2) 72" - XYPEX MH FT REDUCER 48" HOLE - 15"
- P1) 72" - MH BASE Custom Ht, w/XYPEX - 78"
- 1) JOINT WRAP - 0.065"x6"x50' CONSEAL CS212
- 1) JOINT WRAP PRIMER - CONSEAL CS-75 (1 gal.)
- 1) 72" - MH INVERT CHANNEL w/XYPEX - FULL HEIGHT
- 1) 72" - Conseal CS-102 1.00" (Double)
- 2) 48" - Conseal CS-102 1.00" (Double)
- 2) Kor-N-Seal2 - S206-36
- 343.84 SqFt) MASTERSEAL 610 - Two Coats [EXT]

0 lb	Structure Notes:
2251 lb	1. JBS-1155 SANITARY BY ICAST.
4192 lb	2. PER ASTM C478 SPECIFICATIONS.
3864 lb	3. CONCRETE = 5,000 PSI AT 28 DAYS.
14027 lb	4. REINFORCING PER ASTM A615 (GRADE 60).
0 lb	- CONE (As .12)
5422 lb	- TRANS. SLAB - AS SHOWN BY WINFORD PETRONE
0 lb	- RISER/WALLS (As .12)
0 lb	- FLOOR - AS SHOWN BY WINFORD PETRONE
13 lb	
0 lb	

Structure Total:	29769 lb

NOTES:

1. MANUFACTURED TO ASTM C-478 (LATEST REVISION).
2. CONCRETE: 5,000 PSI AT 28 DAYS.
3. XYPEX ADMIXTURE REQUIRED.
4. TWO EXTERNAL COATS OF MASTERSEAL 612
3. REINFORCING: AS SHOWN BY WINFORD PATRONE.
4. TONGUE REQUIRED OFFSET FOR 48"Ø COMPONENTS.

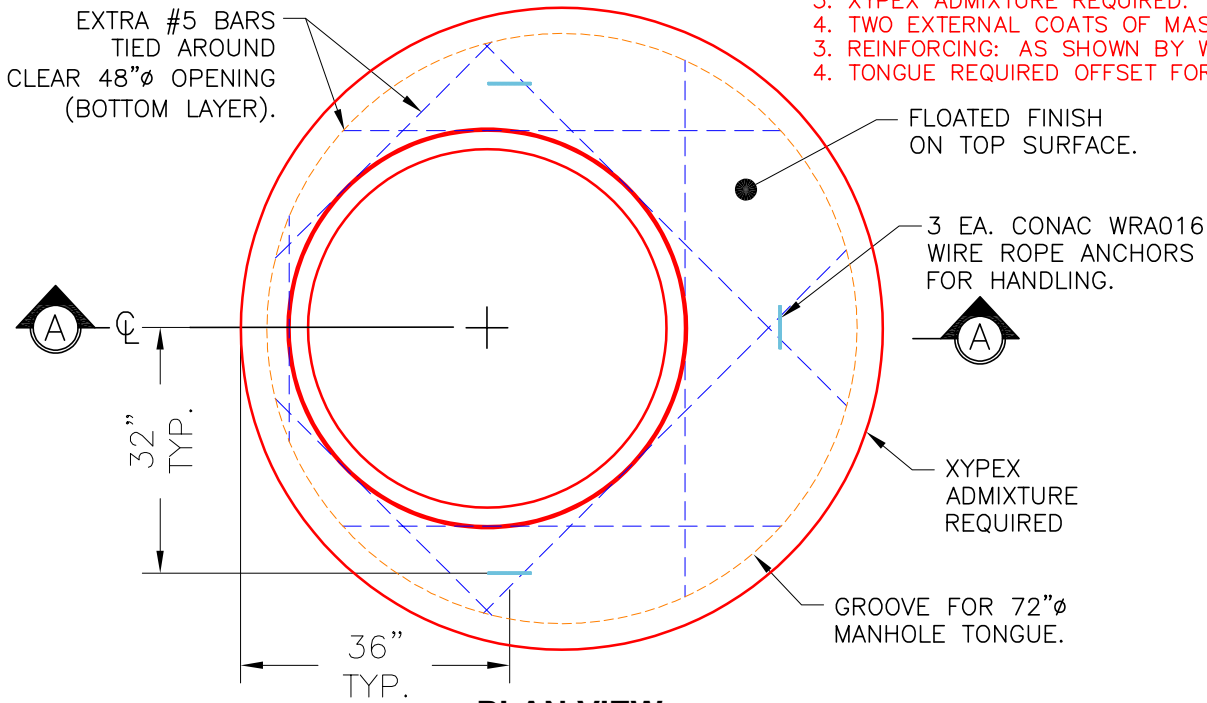

PLAN VIEW

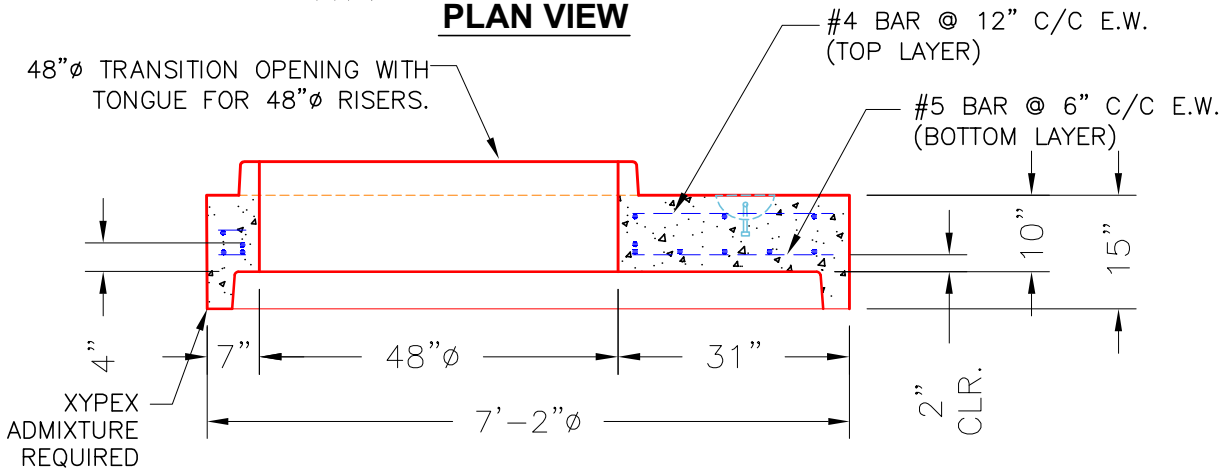

SECTION A-A

Coating (Int):
 Coating (Ext): MASTERSEAL 610

Seam Up: Tongue
 Seam Dn: Groove

Wall Thickness: 7"

Height (Ext): 15"

Weight (Net): 3864 lb
 Volume (Net): 0.99cu.yd

NOTE: SEE "PRECAST DESIGN SUBMITTAL..."
 FOR SUMMARY OF BUILDING AND
 DESIGN CODES, MATERIALS REQUIREMENTS,
 AND DESIGN LOADS.

25-1664 - Springfield WWTP
 Transition Slab Reinforcement Information
 SULPHUR-SSMH-1 2+56.07

NOTE: SEE ICASST WORKING DRAWINGS FOR ADDITIONAL INFORMATION.

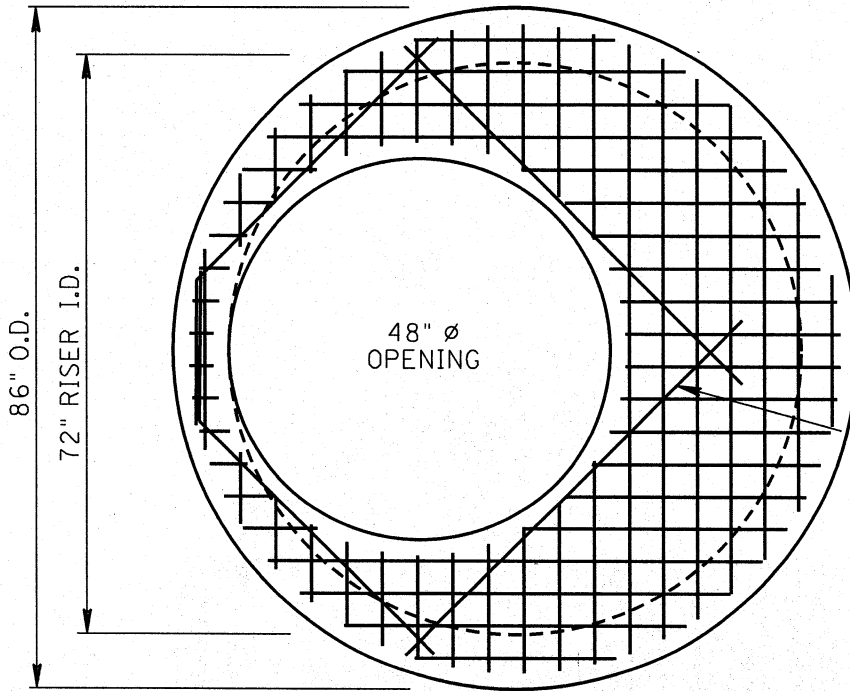

NOTE: PROVIDE #6'S @ 4 1/2" MAX.
 BOTT.-TYP. EACH WAY WITH
 ADDITIONAL #5'S PLACED
 AS SHOWN. PLACE FIRST #6
 ADJACENT TO OPENING AT
 2" CLR. OF OPENING.

#5X5'-0" PLACED OVER
 #6'S. CENTER ON OPENING
 AS SHOWN AND BEND AS
 NEEDED TO MAINTAIN 2"
 CLEAR TO EDGE OF
 SLAB (BOTT.-TYP.)

PLAN

48"Ø RISER STACK
 AND ECCENTRIC CONE
 TO BE IN ACCORDANCE
 WITH ASTM C478

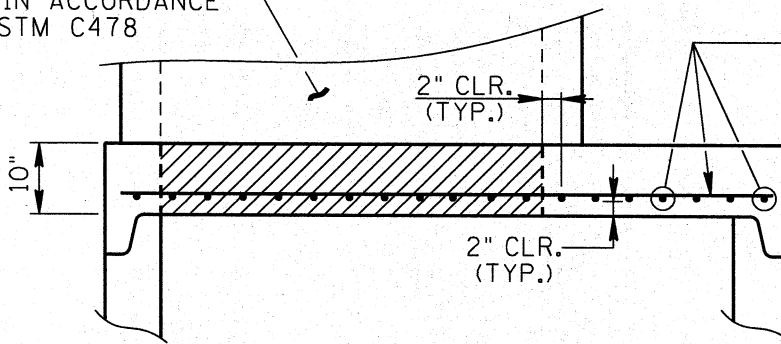

#6'S @ 4 1/2" MAX. EA. WAY:
 PLACE LONGITUDINAL
 LAYER AT 2" CLR.
 AS SHOWN
 (BOTT.-TYP.)

SECTION

TRANSITION SLAB: 72" MANHOLES

THIS DETAIL APPLICABLE TO:
 SULPHUR-SSMH-1, COVER=8.50', OVERALL HT.=16.917'
 SULPHUR-SSMH-2, COVER=15.50', OVERALL HT.=23.75'
 CC SSMH-2, COVER=16.33', OVERALL HT.=24.583'



SK-3