

Job Name: 25-1664 Springfield WWTP
 Job Location: Springfield, TN
 Contractor: Smith Contractors, Inc.

Plant: Beaver Dam

Tech: J. Coppage

3/16/2026 11:58:41 AM

PC: C. Goff



Structure ID: FILTER-UV SAMPLE VAULT

P3 BX036036-08LD08S

CB FLAT TOP 8"W SPEC. (30"x30" HATCH)

- P4) 30" x 30" - HATCH (CAST FLUSH) - 3"
- P3) 36" x 36" - CB FLAT TOP 8"W SPEC. (30"x30" HATCH) - 8"
- P2) 36" x 36" - BOX RISER 8inW, Variable Ht - 47"
- P1) 36" x 36" - P.I.P. BY OTHERS - BTM SLAB - 0"
- 1) 36" x 36" - Conseal CS-102 1.00"
- 3) PSX - 8QRS-S NYLO

100 lb	Structure Notes: 1. MANUFACTURED TO ASTM C-913. 2. CONCRETE: 5,000 PSI AT 28 DAYS 3. REINFORCING: PER ASTM A615 (GRADE 60) 4. (30" X 30" HATCH PROVIDED BY OTHERS) 5. HATCH TO BE CAST INTO THE TOP SLAB.
1215 lb	
5452 lb	
0 lb	
0 lb	
20 lb	
Structure Total:	6786 lb

GENERAL NOTES:

1. MANUFACTURED TO ASTM C-913 (LATEST REVISION).
2. CONCRETE: 5,000 PSI AT 28 DAYS.
3. REINFORCING: #5 BAR @ 4" C-C E.W. PER ASTM A615 (GRADE 60).
4. WEIGHTS:
TOP SLAB = 1,215 LBS
5. HATCH: 30" X 30" HATCH PROVIDED BY OTHERS.
6. HATCH TO BE CAST INTO THE TOP SLAB.
7. VAULT JOINT TO BE SEALED WITH CONCRETE SEALANTS, INC.

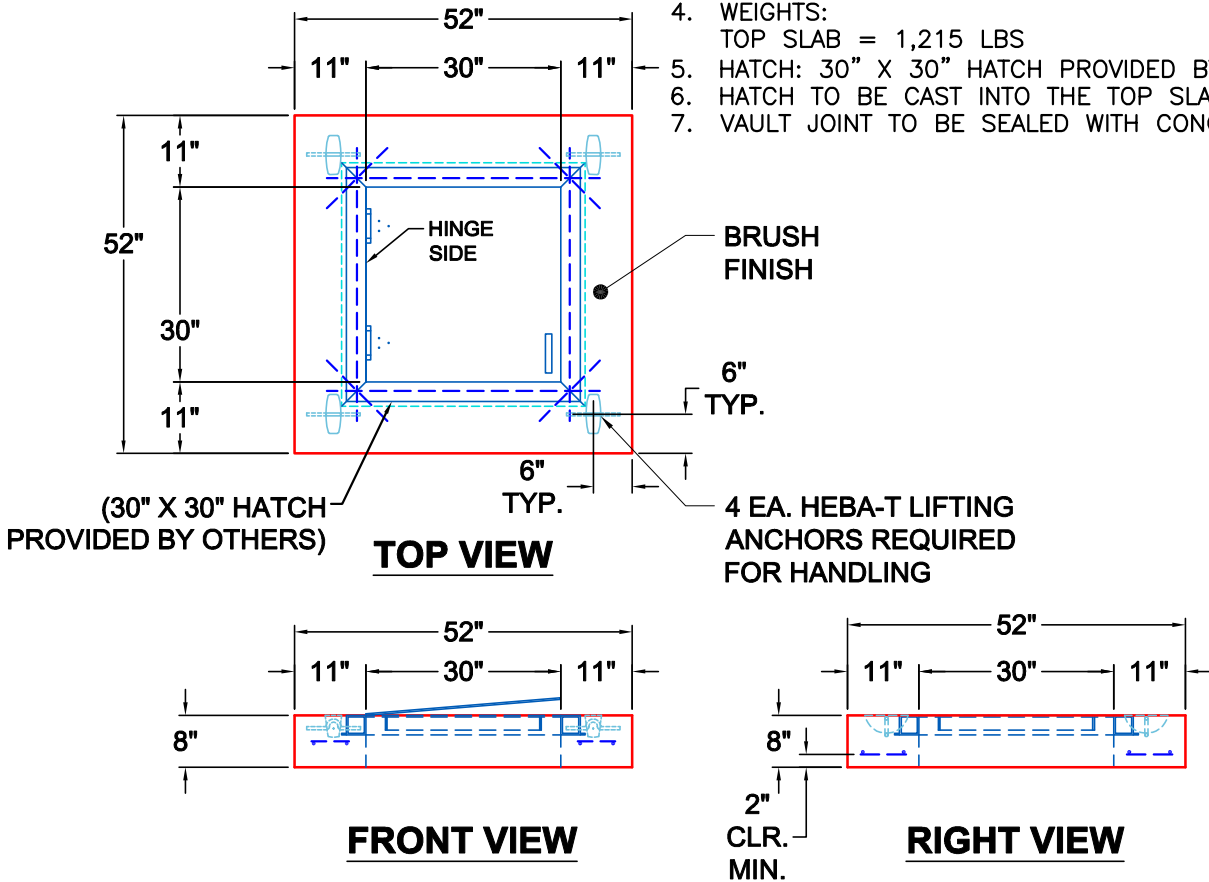

Coating (Int): Coating (Ext):	Seam Up: Flat Seam Dn: Flat	Wall Thickness: 8"	Height (Ext): 8"	Weight (Net): 1215 lb Volume (Net): 0.31cu.yd
----------------------------------	--------------------------------	--------------------	------------------	--