

Job Name: 25-1664 Springfield WWTP
 Job Location: Springfield, TN
 Contractor: Smith Contractors, Inc.

Plant: Beaver Dam

Tech: J. Coppage

3/16/2026 11:59:05 AM

PC: C. Goff



Structure ID: FILTER-UV SAMPLE VAULT

P2 BX363608R-VF

BOX RISER 8inW, Variable Ht

- P4) 30" x 30" - HATCH (CAST FLUSH) - 3"
- P3) 36" x 36" - CB FLAT TOP 8"W SPEC. (30"x30" HATCH) - 8"
- P2) 36" x 36" - BOX RISER 8inW, Variable Ht - 47"
- P1) 36" x 36" - P.I.P. BY OTHERS - BTM SLAB - 0"
- 1) 36" x 36" - Conseal CS-102 1.00"
- 3) PSX - 8QRS-S NYLO

- Structure Notes:**
1. MANUFACTURED TO ASTM C-913.
 2. CONCRETE: 5,000 PSI AT 28 DAYS
 3. REINFORCING: PER ASTM A615 (GRADE 60)
 4. (30" X 30" HATCH PROVIDED BY OTHERS)
 5. HATCH TO BE CAST INTO THE TOP SLAB.

Structure Total: 6786 lb

Rim: 4.58' Rim to Invert: 3.29' Slack: -0.04" Sump: 15.48" Step Position:

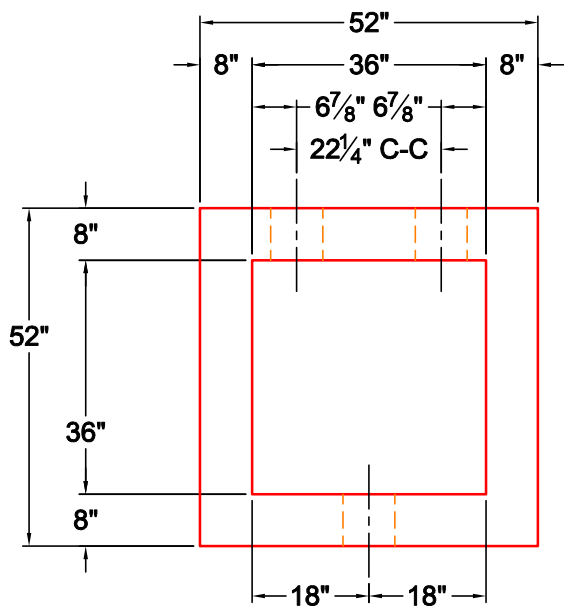

TOP VIEW

GENERAL NOTES:

1. MANUFACTURED TO ASTM C-913 (LATEST REVISION).
2. CONCRETE: 5,000 PSI AT 28 DAYS.
3. REINFORCING: #5 BAR @ 12" C-C E.W. PER ASTM A615 (GRADE 60).
4. WEIGHT:
BASE SECTION = 5,452 LBS
5. VAULT JOINT TO BE SEALED WITH CONCRETE SEALANTS, INC. CS-102 ROLL BUTYL MASTIC. (SUPPLIED BY ICAST)
6. ICAST TO PROVIDE 2X PSX 8QRS-S ND BOOTS FOR 3" PVC PIPE AND 1X PSX 8QRS-S ND BOOT FOR 2" PVC PIPE.

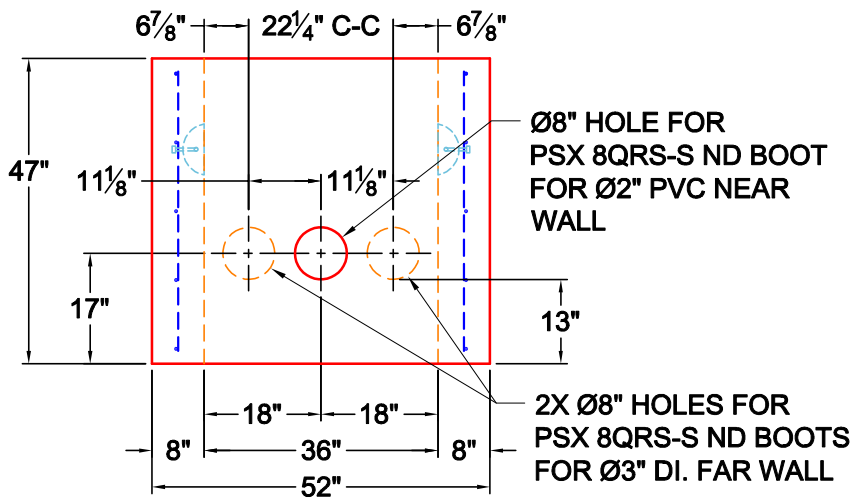

FRONT VIEW

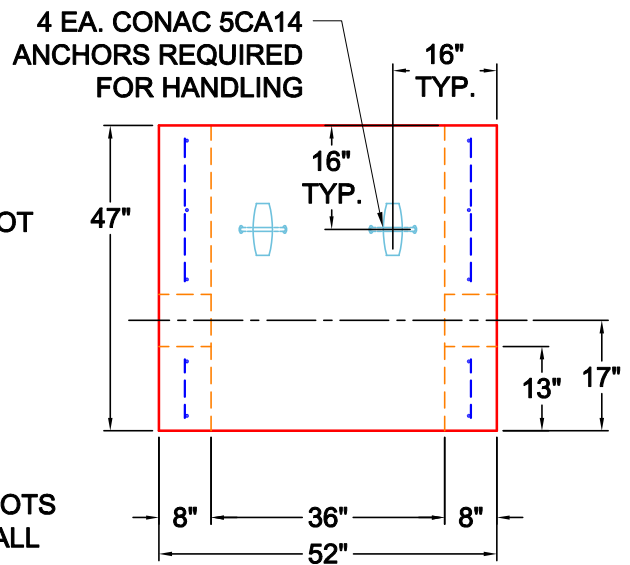

RIGHT VIEW

Coating (Int):
Coating (Ext):

Seam Up: Flat
Seam Dn: Flat

Wall Thickness: 8"
Floor Height: 0"

Height (Int): 47"
Height (Ext): 47"

Weight (Net): 5452 lb
Volume (Net): 1.39cu.yd