

Job Name: 25-1664 Springfield WWTP  
 Job Location: Springfield, TN  
 Contractor: Smith Contractors, Inc.

Plant: Beaver Dam

Tech: J. Coppage

3/16/2026 11:58:41 AM

PC: C. Goff



**Structure ID: 4IN FMV AT FILTER U.V. P.S.**

**P3 BX036036-08LD08S**

**CB FLAT TOP 8"W SPEC. (30"x30" HATCH)**

- P4) 30" x 30" - HATCH (CAST FLUSH) - 3"
- P3) 36" x 36" - CB FLAT TOP 8"W SPEC. (30"x30" HATCH) - 8"
- P2) 36" x 36" - BOX RISER 8inW, Variable Ht - 47"
- P1) 36" x 36" - P.I.P. BY OTHERS - BTM SLAB - 0"
- 1) 36" x 36" - Conseal CS-102 1.00"
- 2) PSX - 8QRS-S NYLO

- |  |   |
|--|---|
| 100 lb<br>1215 lb<br>5485 lb<br>0 lb<br>0 lb<br>13 lb<br>-----<br>Structure Total: 6813 lb | <b>Structure Notes:</b><br>1. MANUFACTURED TO ASTM C-913.<br>2. CONCRETE: 5,000 PSI AT 28 DAYS<br>3. REINFORCING: PER ASTM A615 (GRADE 60)<br>4. (30" X 30" HATCH PROVIDED BY OTHERS)<br>5. HATCH TO BE CAST INTO THE TOP SLAB. |
|--|---|

**GENERAL NOTES:**

1. MANUFACTURED TO ASTM C-913 (LATEST REVISION).
2. CONCRETE: 5,000 PSI AT 28 DAYS.
3. REINFORCING: #5 BAR @ 4" C-C E.W. PER ASTM A615 (GRADE 60).
4. WEIGHTS:  
TOP SLAB = 1,215 LBS
5. HATCH: 30" X 30" HATCH PROVIDED BY OTHERS.
6. HATCH TO BE CAST INTO THE TOP SLAB.
7. VAULT JOINT TO BE SEALED WITH CONCRETE SEALANTS, INC.

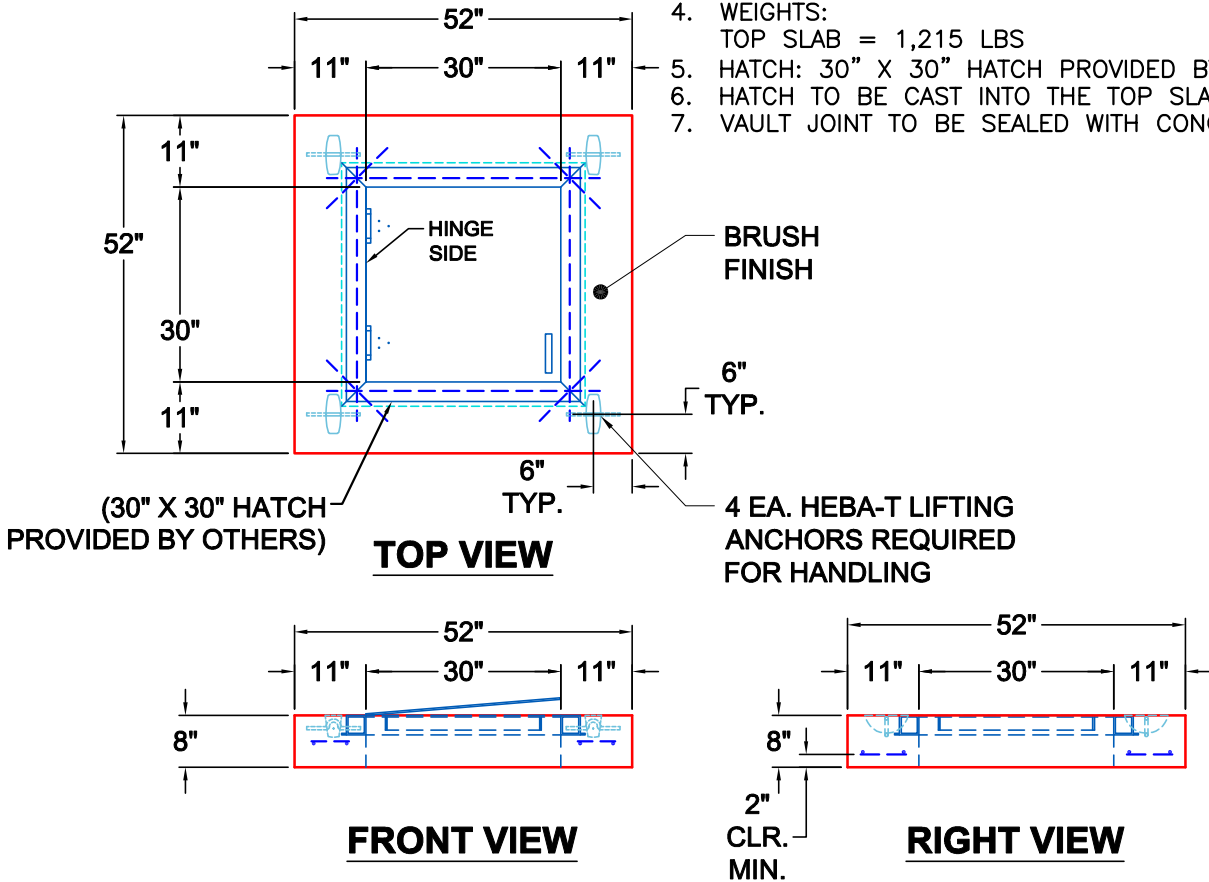

Coating (Int):  
 Coating (Ext):

Seam Up: Flat  
 Seam Dn: Flat

Wall Thickness: 8"

Height (Ext): 8"

Weight (Net): 1215 lb  
 Volume (Net): 0.31cu.yd