

Job Name: 25-1664 Springfield WWTP
 Job Location: Springfield, TN
 Contractor: Smith Contractors, Inc.

Plant: Beaver Dam

Tech: J. Coppage

3/16/2026 11:58:40 AM

PC: C. Goff



Structure ID: 48IN X 48IN FILTER UV VV

P2 BX4848-08LD08X-S

CB FLAT TOP 8"W w/30"X36" HATCH-XYPEX

- P3) 30" x 36" - HATCH (CAST FLUSH) - 3"
- P2) 48" x 48" - CB FLAT TOP 8"W w/30"X36" HATCH-XYPEX - 8"
- P1) 48" x 48" - BOX BASE 8inW, 8inF, Variable Ht.-Xypex - 49"
- 1) 48" x 48" - Conseal CS-102 1.00"
- 1) PSX - 12-06 NYLO
- 2) PSX - 8QRS-S NYLO
- 1) Hole - 4

- Structure Notes:
1. PER ASTM C913 SPECIFICATIONS.
 2. CONCRETE = 5,000 PSI AT 28 DAYS.
 3. NO INVERT CHANNEL.
- REINFORCING PER ASTM A615 (GRADE 60).
- TOP SLAB (As .62) #5 BARS AT 6" C.C.E.W.
 - WALLS (As .31) #5 BARS AT 12" C.C.E.W.
 - FLOOR (As .31) #5 BARS AT 12" C.C.E.W.

Structure Total: 12112 lb

GENERAL NOTES:

1. MANUFACTURED TO ASTM C-913 (LATEST REVISION).
2. CONCRETE: 5,000 PSI AT 28 DAYS.
3. XYPEX ADMIXTURE REQUIRED.
4. REINFORCING: #5 BAR @ 6" C-C E.W. PER ASTM A615 (GRADE 60).
5. WEIGHTS:
TOP SLAB = 2,025 LBS
6. HATCH: 30" X 36" HATCH PROVIDED BY OTHERS.
7. HATCH TO BE CAST INTO THE TOP SLAB.
8. VAULT JOINT TO BE SEALED WITH CONCRETE SEALANTS, INC.

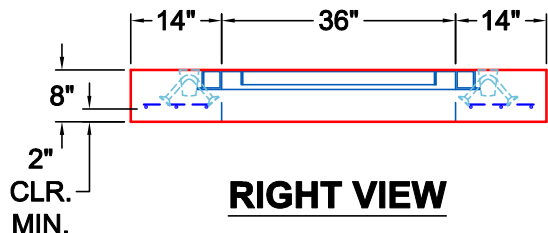
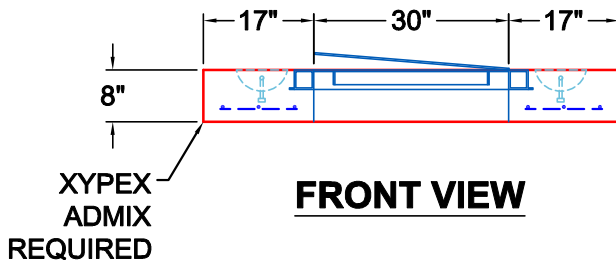
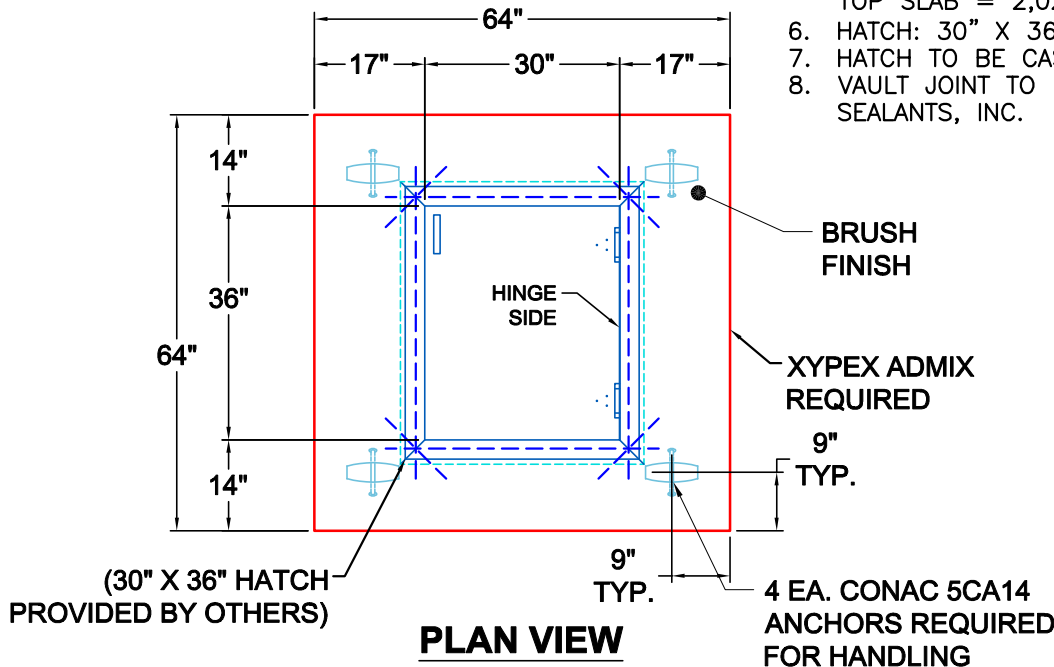

Coating (Int):
 Coating (Ext):

Seam Up: Flat
 Seam Dn: Flat

Wall Thickness: 8"

Height (Ext): 8"

Weight (Net): 2025 lb
 Volume (Net): 0.52cu.yd