

Job Name: 25-1601B Spring Creek Parkway Phase 2 (Sanitary)
 Job Location: Clarksville, TN
 Contractor: Byard Construction, LLC

Plant: Beaver Dam

Tech: S. Felletter

2/18/2026 11:03:46 AM

PC: A. Chambers



Structure ID: B5

P1 MH048BA30X

MH BASE w/XYPEX T/n

- P5) 24" - CASTING HEIGHT - 7"
- P4) 24" - XYPEX GRADE RING F/F - 4"
- P3) 48" - ECC XYPEX CONE w/ 24" HOLE F/G - 30"
- P2) 48" - MH RISER w/XYPEX T/G - 48"
- P1) 48" - MH BASE w/XYPEX T/n - 30"
- 1) JOINT WRAP PRIMER - CONSEAL CS-75 (1 gal.)
- 1) Conseal CS-102 1.00" (Double)
- 1) JOINT WRAP - 0.065"x12"x50' CONSEAL CS212
- 1) 48" - MH INVERT CHANNEL w/XYPEX - FULL HEIGHT
- 2) 48" - Conseal CS-102 1.00" (Double)
- 3) PSX - 12-08 NYLO

0 lb
 270 lb
 1981 lb
 3353 lb
 3282 lb
 0 lb
 0 lb
 0 lb
 1440 lb
 0 lb
 24 lb

 Structure Total: 10350 lb

Structure Notes:

1. PER ASTM C478 SPECIFICATIONS.
 2. CONCRETE = 4,000 PSI AT 28 DAYS.
 3. CASTING BY OTHERS. (JBS-1155 F/C)
 4. EXTERIOR STAINLESS STEEL JOINT STRAPS TO BE PROVIDED BY OTHERS.
 5. NO STEPS.
- REINFORCING PER ASTM A615 (GRADE 60).
 - CONE (As .12)
 - RISER (As .12)
 - FLOOR (As .31) #5 BARS AT 12" C.C.E.W.

Rim: 511.95' Rim to Invert: 9.8' Slack: 0.6" Sump: 2" Step Position:

Position	Elev	Angle	Ext. (cw)	Pipe	Pipe OD	Connector	Hole	Horz Size	Up ()	Offset
Invert 1	502.15'	0°	0"	8" PVC SDR26	8.5"	PSX 12-08 NYLO	12"	12.129"	0"	0"
Invert 2	502.25'	130°	65.799"	8" PVC SDR26	8.5"	PSX 12-08 NYLO	12"	12.129"	1.2"	0"
Invert 3	502.25'	270°	136.659"	8" PVC SDR26	8.5"	PSX 12-08 NYLO	12"	12.129"	1.2"	0"
Invert 4										
Invert 5										
Invert 6										
Invert 7										
Invert 8										

RIGHT-SIDE UP VIEW (int. dimensions)

UPSIDE-DOWN VIEW (int. dimensions)

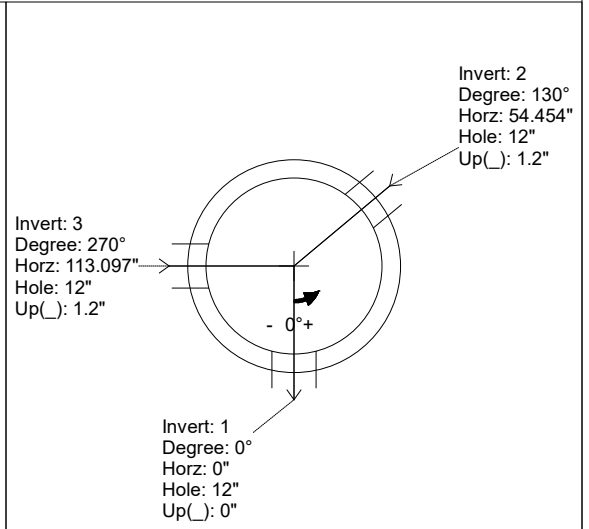
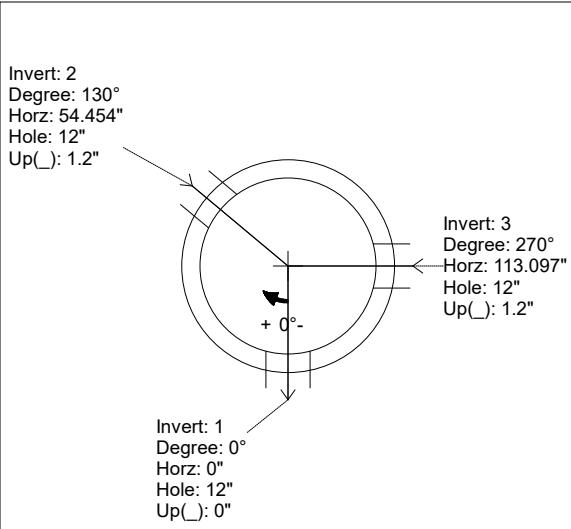
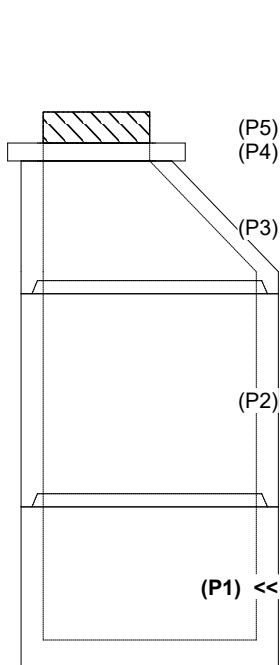

INSIDE WALL DIMENSIONS

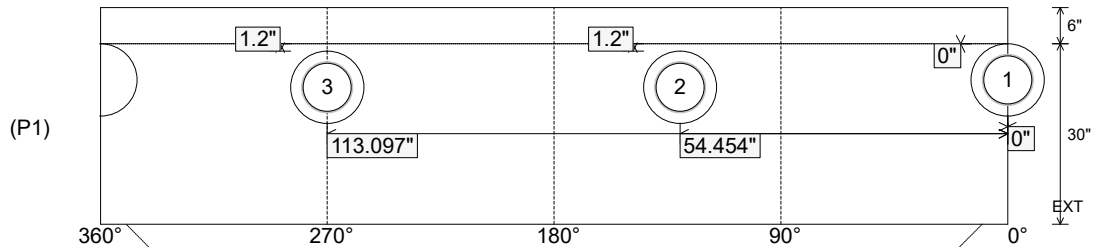

Coating (Int):
 Coating (Ext):

Seam Up: Tongue
 Seam Dn: n/a

Wall Thickness: 5"
 Floor Height: 6"

Height (Int): 30"
 Height (Ext): 36"

Weight (Net): 3282 lb
 Volume (Net): 0.84cu.yd

Job Name: 25-1601B Spring Creek Parkway Phase 2 (Sanitary)
 Job Location: Clarksville, TN
 Contractor: Byard Construction, LLC

Plant: Beaver Dam

Tech: S. Felletter

2/18/2026 11:03:46 AM

PC: A. Chambers



Structure ID: B5

P1 MH048BA30X

MH BASE w/XYPEX T/n

- P5) 24" - CASTING HEIGHT - 7"
- P4) 24" - XYPEX GRADE RING F/F - 4"
- P3) 48" - ECC XYPEX CONE w/ 24" HOLE F/G - 30"
- P2) 48" - MH RISER w/XYPEX T/G - 48"
- P1) 48" - MH BASE w/XYPEX T/n - 30"
- 1) JOINT WRAP PRIMER - CONSEAL CS-75 (1 gal.)
- 1) Conseal CS-102 1.00" (Double)
- 1) JOINT WRAP - 0.065"x12"x50' CONSEAL CS212
- 1) 48" - MH INVERT CHANNEL w/XYPEX - FULL HEIGHT
- 2) 48" - Conseal CS-102 1.00" (Double)
- 3) PSX - 12-08 NYLO

0 lb
 270 lb
 1981 lb
 3353 lb
 3282 lb
 0 lb
 0 lb
 0 lb
 1440 lb
 0 lb
 24 lb

 Structure Total: 10350 lb

Structure Notes:

1. PER ASTM C478 SPECIFICATIONS.
 2. CONCRETE = 4,000 PSI AT 28 DAYS.
 3. CASTING BY OTHERS. (JBS-1155 F/C)
 4. EXTERIOR STAINLESS STEEL JOINT STRAPS TO BE PROVIDED BY OTHERS.
 5. NO STEPS.
- REINFORCING PER ASTM A615 (GRADE 60).
 - CONE (As .12)
 - RISER (As .12)
 - FLOOR (As .31) #5 BARS AT 12" C.C.E.W.

Invert channel drawing - full height invert

Rim: 511.95' Rim to Invert: 9.8' Slack: 0.6" Sump: 2' Step Position:

Position	Elev	Angle	Ext. (cw)	Pipe	Pipe OD	Connector	Hole	Horz Size	Up ()	Offset
Invert 1	502.15'	0°	0"	8" PVC SDR26	8.5"	PSX 12-08 NYLO	12"	12.129"	0"	0"
Invert 2	502.25'	130°	65.799"	8" PVC SDR26	8.5"	PSX 12-08 NYLO	12"	12.129"	1.2"	0"
Invert 3	502.25'	270°	136.659"	8" PVC SDR26	8.5"	PSX 12-08 NYLO	12"	12.129"	1.2"	0"
Invert 4										
Invert 5										
Invert 6										
Invert 7										
Invert 8										

RIGHT-SIDE UP VIEW (int. dimensions)

UPSIDE-DOWN VIEW (int. dimensions)

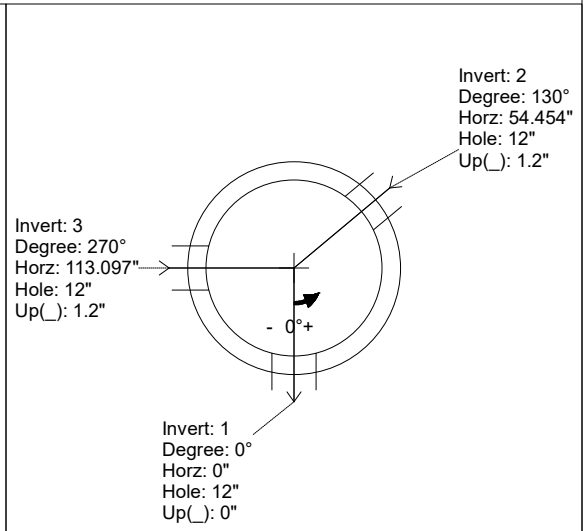
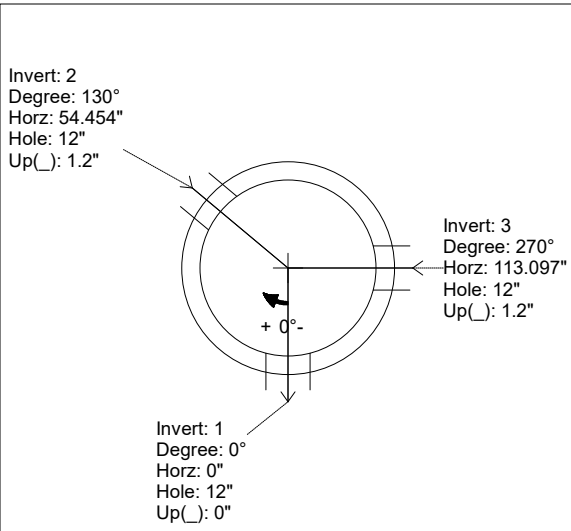
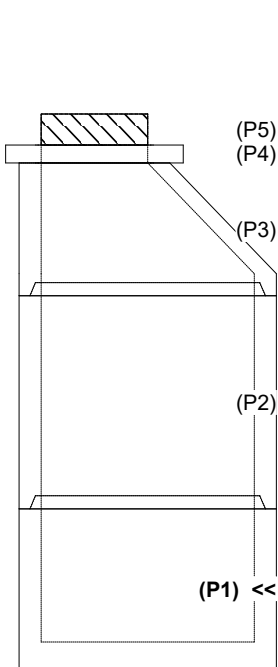

INSIDE WALL DIMENSIONS

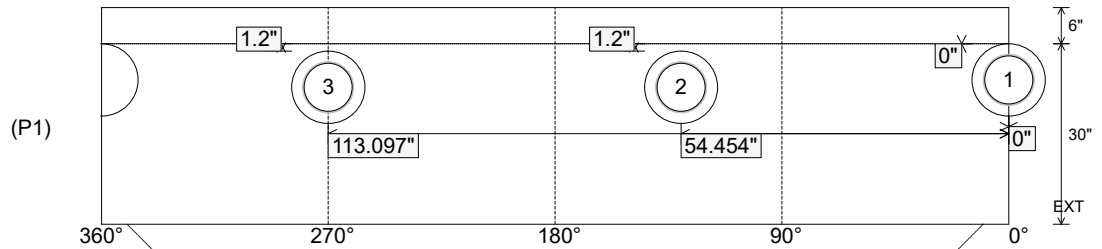

Coating (Int):
 Coating (Ext):

Seam Up: Tongue
 Seam Dn: n/a

Wall Thickness: 5"
 Floor Height: 6"

Height (Int): 30"
 Height (Ext): 36"

Weight (Net): 3282 lb
 Volume (Net): 0.84cu.yd