

- GENERAL NOTES:**
1. MANUFACTURED TO ASTM C-913 (LATEST REVISION).
 2. CONCRETE: 5,000 PSI AT 28 DAYS.
 3. XYPEX ADMIXTURE REQUIRED.
 4. REINFORCING: PER REINFORCEMENT DESIGN PROVIDED BY MATT CHILDS ENGINEERING PER ASTM A615 (GRADE 60).
 5. WEIGHT: 15,386 LBS
 6. HATCHES: HALLIDAY H2W 48" X 48" HATCH AND HALLIDAY H1W 30" X 30" HATCH PROVIDED BY ICAST.
 7. HATCHES TO BE CAST IN TOP SLAB.
 8. TOP SLAB SHALL BE CROWNED OR SLOPED TO DRAIN, 1/4" PER FOOT.

TOP VIEW

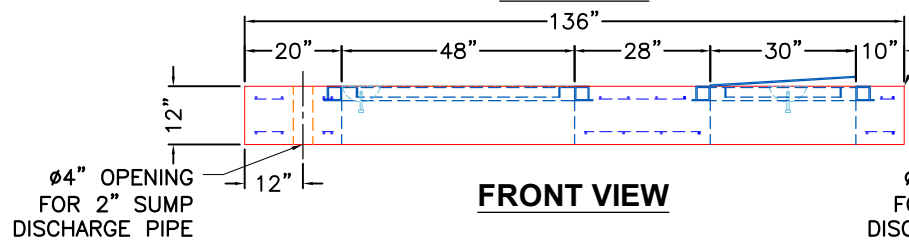

FRONT VIEW

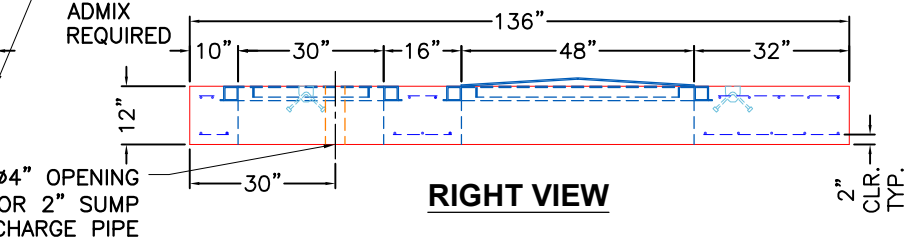

RIGHT VIEW

PRODUCTION WORK ORDER		PRODUCT I.D.: CTS-X	DESCRIPTION: 136" X 136" X 12" THICK TOP SLAB W/ XYPEX	
	QUALITY CONTROL CHECKLIST	PRODUCT VIEW: RIGHT SIDE UP	CUSTOMER: CUMBERLAND VALLEY CONSTRUCTORS, INC.	
	<input type="checkbox"/> ALL DIMENSIONS CORRECT.	PLANT: BEAVER DAM, KY.	PROJECT: STONES RIVER WTP ISOLATION VALVE REPLACEMENT	
	<input type="checkbox"/> LIFTERS INSTALLED.	WEIGHT: 15,386 LBS.	STRUCTURE: 120IN X 120IN VAULT	
	<input type="checkbox"/> XYPEX ADMIXTURE USED.	TOP SECTION JOINT: N/A	ORDER NO: 25-1549	
	<input type="checkbox"/> REINFORCING CORRECT.	BASE SECTION JOINT: N/A	PC: J. JARVIS	DRAWING: J. COPPAGE
<input type="checkbox"/> SURFACE QUALITY ACCEPTABLE.	QC CHECK INITIALS:	DATE: 9/8/25	SCALE: NTS	PG. 1 of 1
<input type="checkbox"/> EDGES CHAMFERED.				
<input type="checkbox"/> ALL PATCHWORK ACCEPTABLE.				

DESIGN NOTE:

HS20 LOADING - ASTM C890
 CONCRETE 28 DAY COMPRESSIVE STRENGTH - 5000 PSI
 REINFORCEMENT STEEL - 60,000 PSI
 REBAR MIN SPLICE LENGTHS: #4-22" #5-28" #6-33"
 PLACE 4-#4 BAR DIAGONAL AROUND OPENING(S)

STEEL REINFORCEMENT SHOWN BELOW SHALL BE CUT AS REQUIRED FOR WALL PENETRATIONS AND PRECAST JOINT LOCATIONS.
 PLEASE NOTE: DUE TO PRECAST PRODUCTION CONSTRAINTS, NO REINFORCING WILL BE CONTINUOUS ACROSS PRECAST JOINTS.

**25-1549
 STONES RIVER WTP ISOLATION VALVE REPLACEMENT
 120IN X 120IN VAULT**

REINFORCING STEEL SCHEDULE

MARK	NO.	LENGTH	TYPE	lb/EA	TOTAL LB	BENDING DIAGRAM	
						Diagram 1	Diagram 2
5A	12	11'-1"	STR.	11,5599	138,719		
5B	12	11'-1"	STR.	11,5599	138,719		
5C	18	11'-1"	STR.	11,5599	208,0782		
5D	18	11'-1"	STR.	11,5599	208,0782		
5E	8	24'-0" (2)	BENT	25,032	400,512		
5F	56	9'-1"	BENT	9,4739	530,5393		
5G	14	11'-2"	STR.	11,6468	163,0552		
5H	14	11'-2"	STR.	11,6468	163,0552		

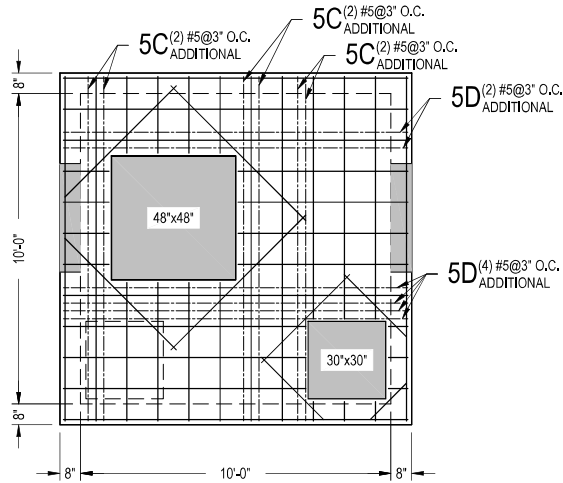

PLAN VIEW
 (TOP SLAB - BOTTOM MAT)

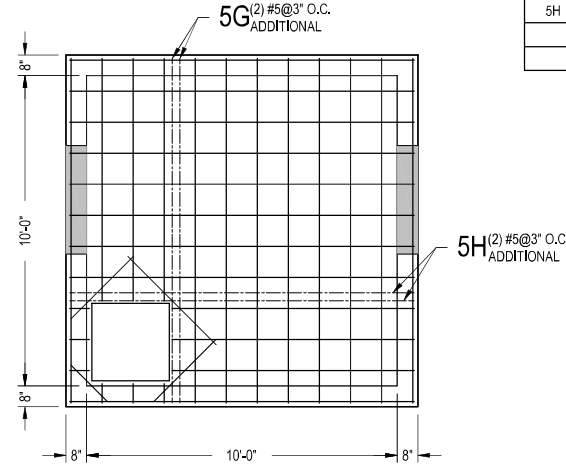

PLAN VIEW
 (BOTTOM SLAB - TOP MAT)

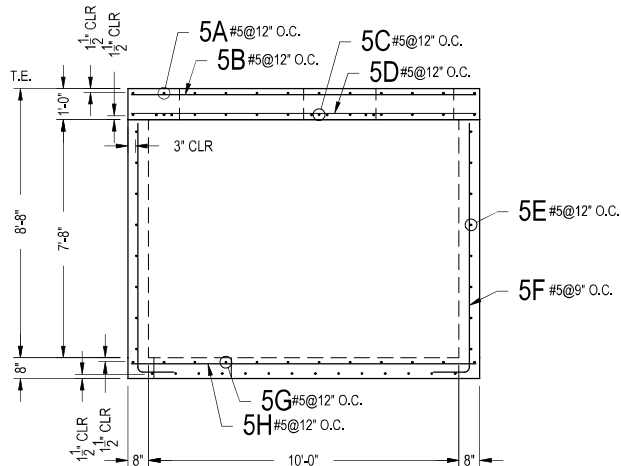

FRONT VIEW

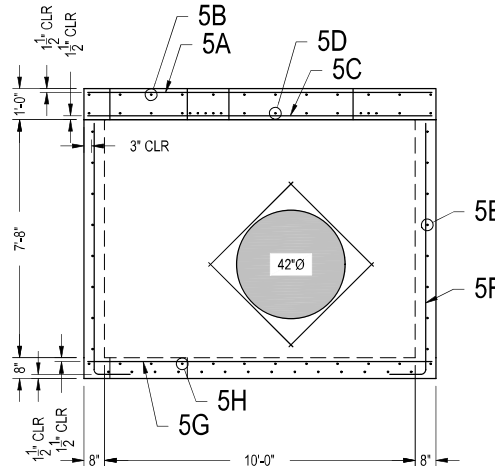

RIGHT VIEW

VAULT
 10'-0" x 10'-0"
 INFRASTRUCTURE PRECAST
 STONES RIVER ISOLATION
 DATE: 9/12/25
 PAGE: 1 OF 1

DRAWN BY: MBJ
 SCALE: 1/4" = 1'

REVISIONS	
NO.	DESCRIPTION
A	
B	
C	
D	

V-01

MATT PHILLOS ENGINEERING, PLLC
 519 E. INVERFAIRLE DR., #017
 ROCKWALL, TX 75087