

Job Name: 25-1511 Halfhill Estates Ph.3  
 Job Location: Nicholasville, KY  
 Contractor: Perdue Environmental Contracting Co., Inc.

Plant: Beaver Dam

Tech: J. Horsley

12/16/2025 4:35:35 PM

PC: J. Jarvis



**Structure ID: MH N7**

**P1 MH048BA30CDARED**

**MH BASE w/ConBlock-CDA Red T/n**

P3) 24" - CASTING HEIGHT - 7"	0 lb
P2) 48" - ECC CONE w/ 24" HOLE, w/ConBlock-CDA Red F/G - 36"	2251 lb
P1) 48" - MH BASE w/ConBlock-CDA Red T/n - 30"	3378 lb
1) 48" - MH INVERT CHANNEL w/ConBlock-CDA Red - FULL HEIGHT	1440 lb
1) JOINT WRAP - 0.065"x6"x50' CONSEAL CS212	0 lb
1) JOINT WRAP PRIMER - CONSEAL CS-75 (1 gal.)	0 lb
1) CASTING - HOE MC-350 F/C Sanitary	305 lb
1) 48" - Conseal CS-102 1.00" (Double)	0 lb
1) PSX - 12-08 NYLO	8 lb
2) MH Step ML-10-TDS-NCR - 10"	0 lb
<b>Structure Total:</b>	<b>7382 lb</b>

**Structure Notes:**  
 1. PER ASTM C478 SPECIFICATIONS.  
 2. CONCRETE = 4,000 PSI AT 28 DAYS.  
 3. ADMIXTURE = CONBLOCK CDA RED.  
 4. CASTING BY ICAST (HOE MC-350 F/C)

REINFORCING PER ASTM A615 (GRADE 60).  
 - CONE (As .12)  
 - RISER/WALLS (As .12)  
 - FLOOR (As .31) #5 BARS AT 12" C.C.E.W.

Rim: 898.88' Rim to Invert: 5.94' Slack: 0.28" Sump: 2" Step Position: 0°

Position	Elev	Angle	Ext. (cw)	Pipe	Pipe OD	Connector	Hole	Horz Size	Up ( )	Offset
Invert 1	892.94'	0°	0"	8" PVC SDR35	8.5"	PSX 12-08 NYLO	12"	12.129"	0"	0"
Invert 2										
Invert 3										
Invert 4										
Invert 5										
Invert 6										
Invert 7										
Invert 8										

RIGHT-SIDE UP VIEW (int. dimensions)

UPSIDE-DOWN VIEW (int. dimensions)

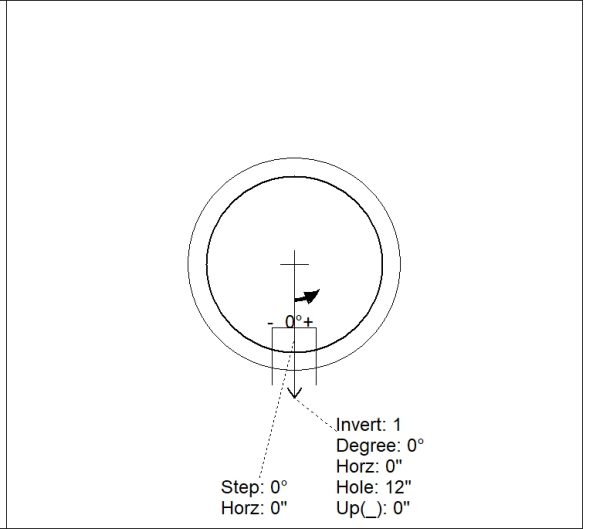
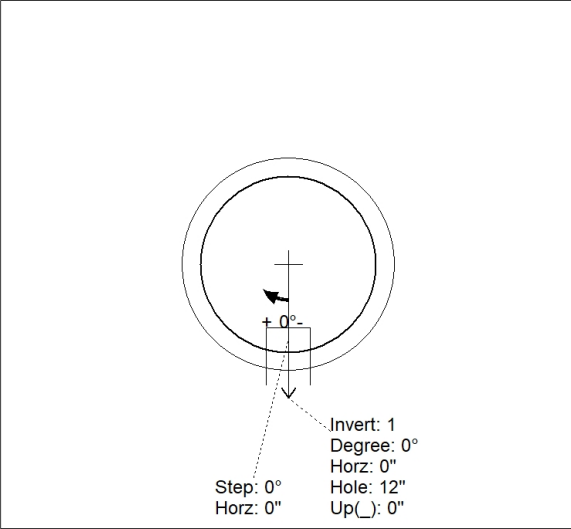
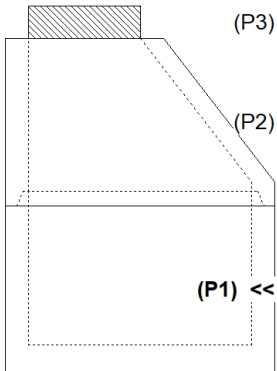

INSIDE WALL DIMENSIONS

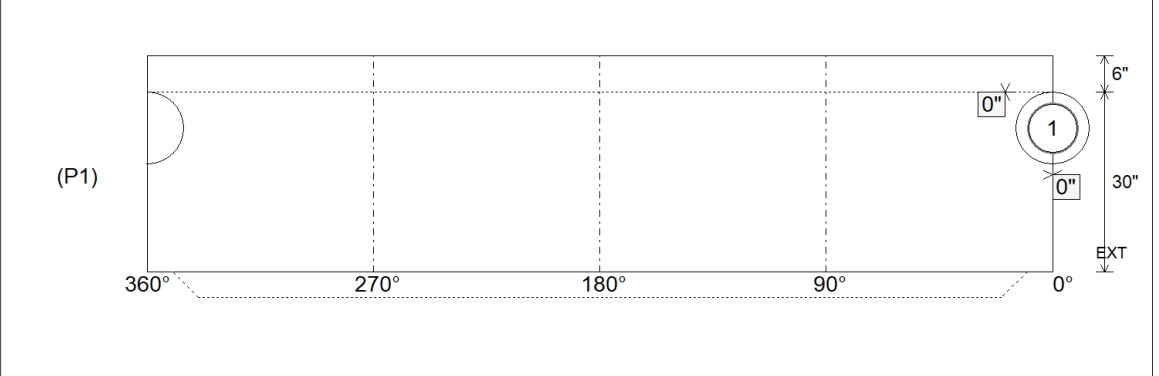

Coating (Int): Coating (Ext):	Seam Up: Tongue Seam Dn: n/a	Wall Thickness: 5" Floor Height: 6"	Height (Int): 30" Height (Ext): 36"	Weight (Net): 3378 lb Volume (Net): 0.86cu.yd
----------------------------------	---------------------------------	--	--	--

Job Name: 25-1511 Halfhill Estates Ph.3  
 Job Location: Nicholasville, KY  
 Contractor: Perdue Environmental Contracting Co., Inc.

Plant: Beaver Dam  
 12/16/2025 4:35:35 PM

Tech: J. Horsley  
 PC: J. Jarvis



**Structure ID: MH N7**

**P1A MH048BA30CDARED**

**MH BASE w/ConBlock-CDA Red T/n**

P3) 24" - CASTING HEIGHT - 7"	0 lb
P2) 48" - ECC CONE w/ 24" HOLE, w/ConBlock-CDA Red F/G - 36"	2251 lb
P1) 48" - MH BASE w/ConBlock-CDA Red T/n - 30"	3378 lb
1) 48" - MH INVERT CHANNEL w/ConBlock-CDA Red - FULL HEIGHT	1440 lb
1) JOINT WRAP - 0.065"x6"x50' CONSEAL CS212	0 lb
1) JOINT WRAP PRIMER - CONSEAL CS-75 (1 gal.)	0 lb
1) CASTING - HOE MC-350 F/C Sanitary	305 lb
1) 48" - Conseal CS-102 1.00" (Double)	0 lb
1) PSX - 12-08 NYLO	8 lb
2) MH Step ML-10-TDS-NCR - 10"	0 lb
<b>Structure Total:</b>	<b>7382 lb</b>

Structure Notes:  
 1. PER ASTM C478 SPECIFICATIONS.  
 2. CONCRETE = 4,000 PSI AT 28 DAYS.  
 3. ADMIXTURE = CONBLOCK CDA RED.  
 4. CASTING BY ICAST (HOE MC-350 F/C)

REINFORCING PER ASTM A615 (GRADE 60).  
 - CONE (As .12)  
 - RISER/WALLS (As .12)  
 - FLOOR (As .31) #5 BARS AT 12" C.C.E.W.

Rim: 898.88' Rim to Invert: 5.94' Slack: 0.28" Sump: 2" Step Position: 0°

Position	Elev	Angle	Ext. (cw)	Pipe	Pipe OD	Connector	Hole	Horz Size	Up ( )	Offset
Invert 1	892.94'	0°	0"	8" PVC SDR35	8.5"	PSX 12-08 NYLO	12"	12.129"	0"	0"
Invert 2										
Invert 3										
Invert 4										
Invert 5										
Invert 6										
Invert 7										
Invert 8										

RIGHT-SIDE UP VIEW (int. dimensions)

UPSIDE-DOWN VIEW (int. dimensions)

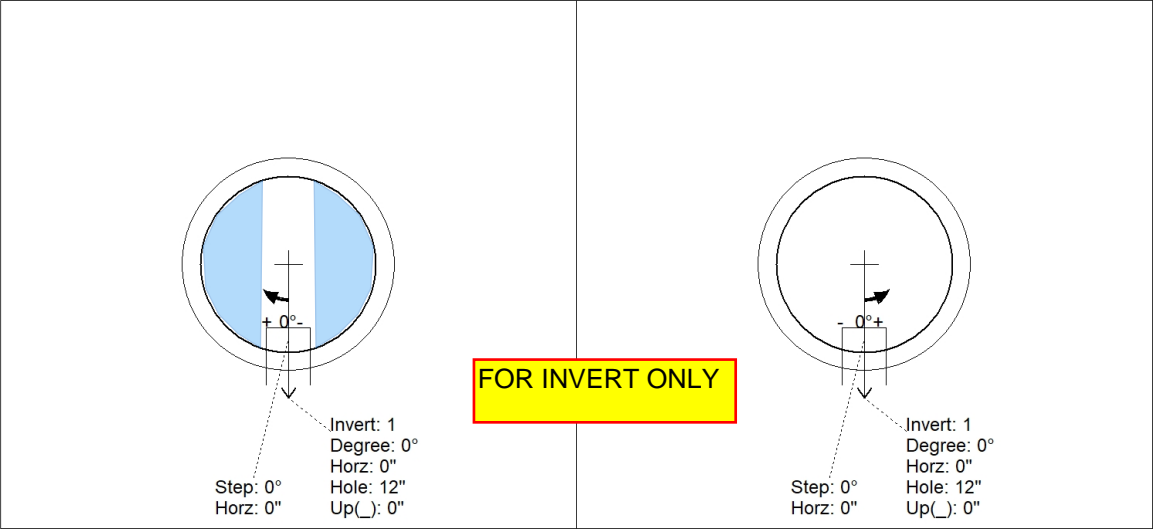
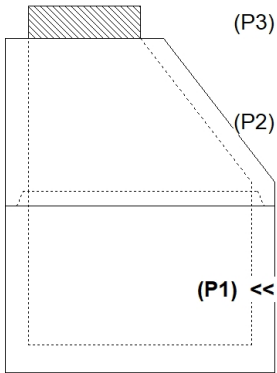

INSIDE WALL DIMENSIONS

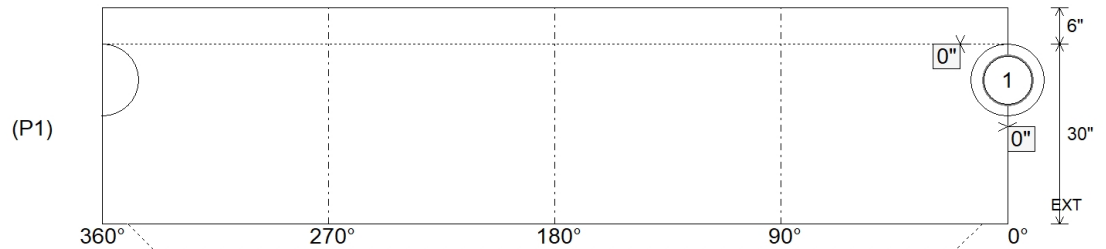

Coating (Int): Coating (Ext):	Seam Up: Tongue Seam Dn: n/a	Wall Thickness: 5" Floor Height: 6"	Height (Int): 30" Height (Ext): 36"	Weight (Net): 3378 lb Volume (Net): 0.86cu.yd
----------------------------------	---------------------------------	--	--	--