

Job Name: 25-1511 Halfhill Estates Ph.3
Job Location: Nicholasville, KY
Contractor: Perdue Environmental Contracting Co., Inc.

PC: J. Jarvis
 TECH: J. Horsley
 Plant: Beaver Dam



Structure ID: MH K4

Spec: Sanitary
 Type: SAN.MH w/ConBlock-CDA Red
 Size: 48"

Rim: 891.21'
 Invert: 885.11'
 Rim to Invert: 6.1'

Sump: 2"
 Floor (Top): 884.943'
 Floor Height: 6"

Floor (Bot): 884.443'
 Overall Height: 6.75'
 Slack: 0.2"

Structure Notes:

1. PER ASTM C478 SPECIFICATIONS.
2. CONCRETE = 4,000 PSI AT 28 DAYS.
3. ADMIXTURE = CONBLOCK CDA RED.
4. CASTING BY ICAST (HOE MC-350 F/C)

REINFORCING PER ASTM A615 (GRADE 60).
 - CONE (As .12)
 - RISER/WALLS (As .12)
 - FLOOR (As .31) #5 BARS AT 12" C.C.E.W.

STRUCTURE SUMMARY:

P3) 24" - CASTING HEIGHT - 7"	0 lb
P2) 48" - ECC CONE w/ 24" HOLE, w/ConBlock-CDA Red F/G - 36"	2251 lb
P1) 48" - MH BASE Custom Ht, w/ConBlock-CDA Red T/n - 32"	3422 lb
1) 48" - MH INVERT CHANNEL w/ConBlock-CDA Red - FULL HEIGHT	1440 lb
1) JOINT WRAP - 0.065"x6"x50' CONSEAL CS212	0 lb
1) JOINT WRAP PRIMER - CONSEAL CS-75 (1 gal.)	0 lb
1) CASTING - HOE MC-350 F/C Sanitary	305 lb
1) 48" - Con Seal CS-102 1.00" (Double)	0 lb
3) PSX - 12-08 NYLO	24 lb
6) MH Step ML-10-TDS-NCR - 10"	0 lb
Structure Total:	7442 lb

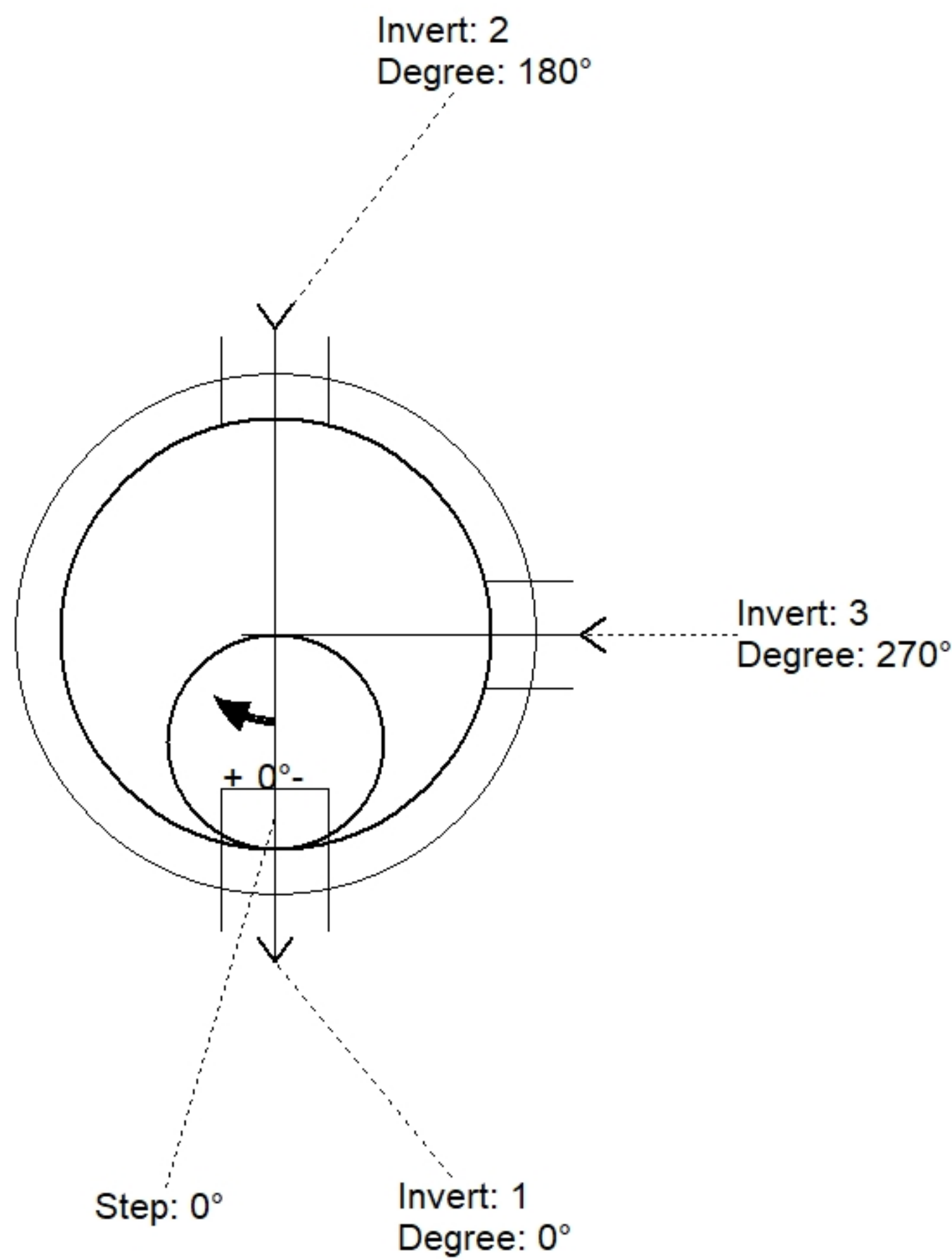

Position	Elev	Angle	Pipe	Pipe OD	Hole	Connector	Up (")	Ref
Rim	891.21'							
Reducer								
Invert 1	885.11'	0°	8" PVC SDR35	8.5"	12"	PSX 12-08 NYLO	0"	P1
Invert 2	885.21'	180°	8" PVC SDR35	8.5"	12"	PSX 12-08 NYLO	1.25"	P1
Invert 3	885.21'	270°	8" PVC SDR35	8.5"	12"	PSX 12-08 NYLO	1.25"	P1
Invert 4								
Invert 5								
Invert 6								
Invert 7								
Invert 8								

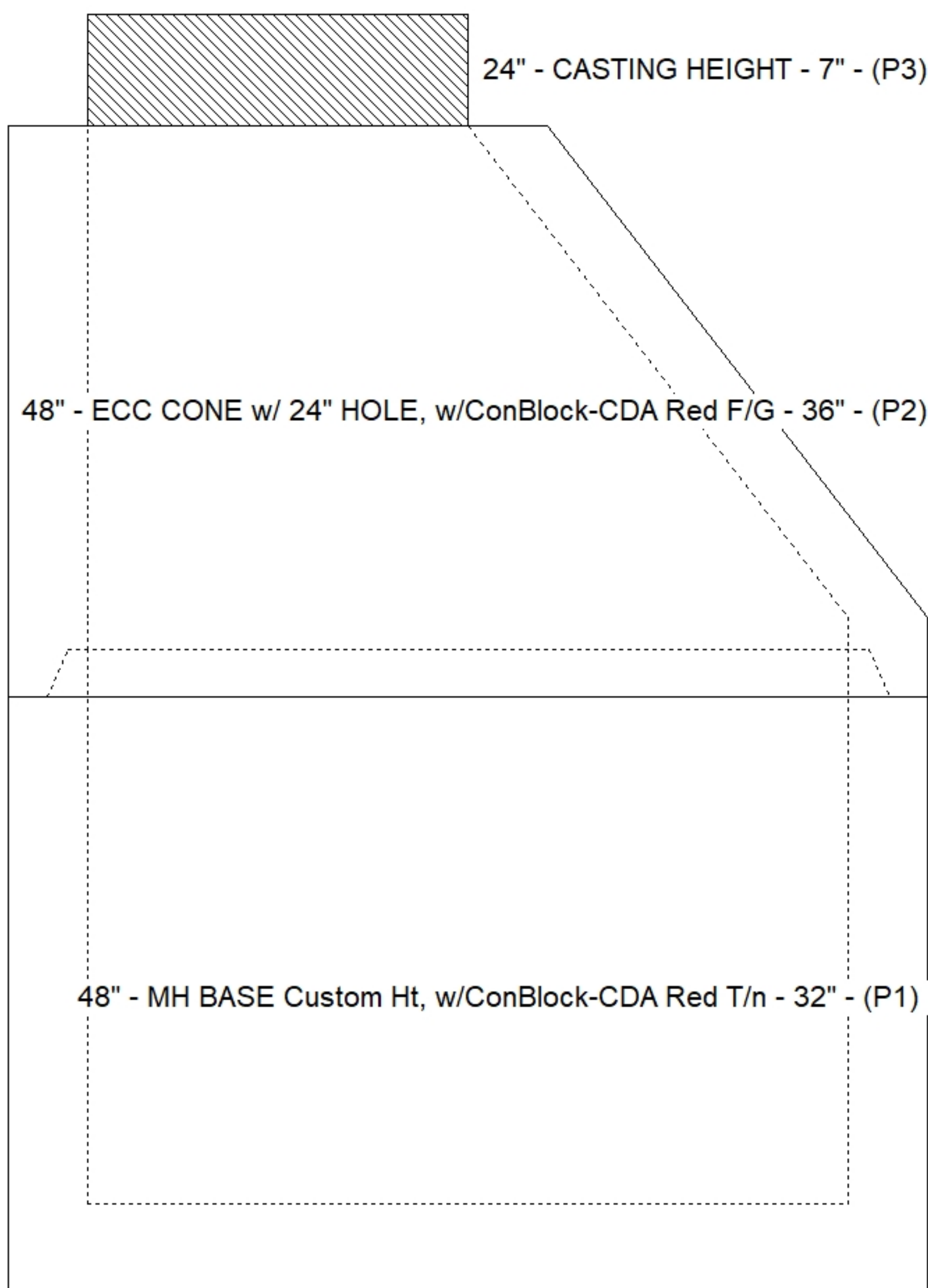

Cast (Int. Dim.) - Interior Dimensions

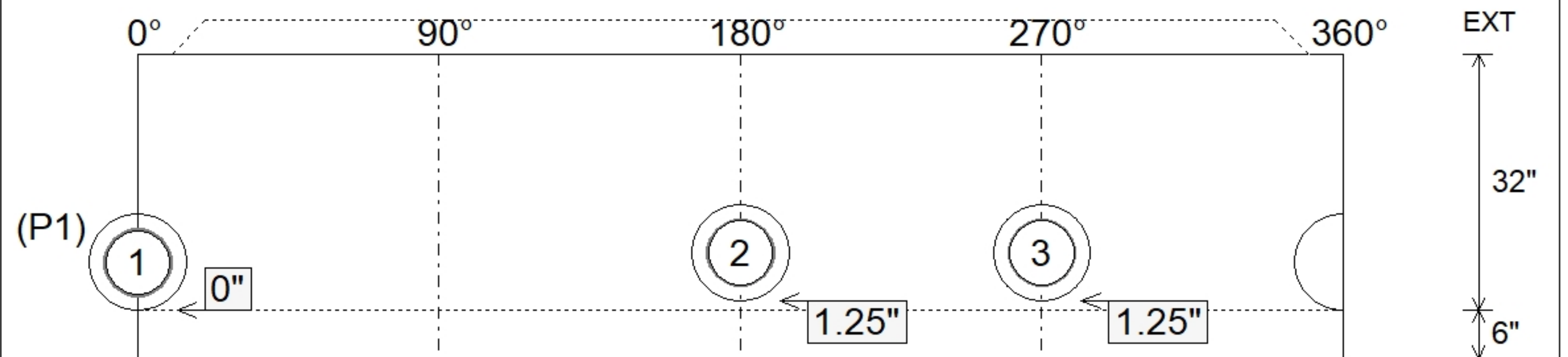

Submittal Drawing
 12/16/2025 4:34:55 PM

SUBMITTAL
 APPROVED BY: