

Job Name: 25-1511 Halfhill Estates Ph.3
Job Location: Nicholasville, KY
Contractor: Perdue Environmental Contracting Co., Inc.

PC: J. Jarvis
 TECH: J. Horsley
 Plant: Beaver Dam



Structure ID: **CBI 2001**
 Spec: KYTC
 Type: CBI TYPE A (10')
 Size: 36" x 36"

Rim: 881.15'
 Invert: 871.04'
 Rim to Invert: 10.11'

Sump: 0"
 Floor (Top): 871.04'
 Floor Height: 8"

Floor (Bot): 870.373'
 Overall Height: 10.75'
 Slack: 0.32"

Structure Notes:

- ** KYTC STATE PROJECT **
- PER KYTC CBI TYPE A / ASTM C913 SPEC'S.
 - CONCRETE = 4,000 PI AT 28 DAYS.
 - NO INVERT CHANNEL.
- REINFORCING PER ASTM A615 (GRADE 60).
 - TOP PHASE (As .62) #5 BARS AT 6" C.C.E.W.
 - TRANS. SLAB (As .62) #5 BARS AT 6" C.C.E.W (DBL MAT)
 - WALLS (As .31) #5 BARS AT 12" C.C.E.W.
 - FLOOR (As .31) #5 BARS AT 12" C.C.E.W.

STRUCTURE SUMMARY:

P5) 24" x 120" - CB INLET KY A 10' TOP LEFT F/G - 10"	3400 lb
P4) 24" x 120" - CB INLET KY A 10' BOTTOM LEFT T/G - 18"	5270 lb
P3) 24" x 36" - BOX RISER 8inW, Variable Ht T/G - 25"	2551 lb
P2) 36" x 36" - CB TRANSITION SLAB 24"X36" HOLE T/F - 8"	1235 lb
P1) 36" x 36" - BOX BASE 8inW, 8inF F/n - 60"	7925 lb
1) CASTING - HOE KY-206 F/C (KY TY1)	206 lb
1) 36" x 36" - Conseal CS-102 1.00"	0 lb
2) 24" x 36" - Conseal CS-102 1.00"	0 lb
2) Hole - 30	0 lb
Structure Total:	20586 lb

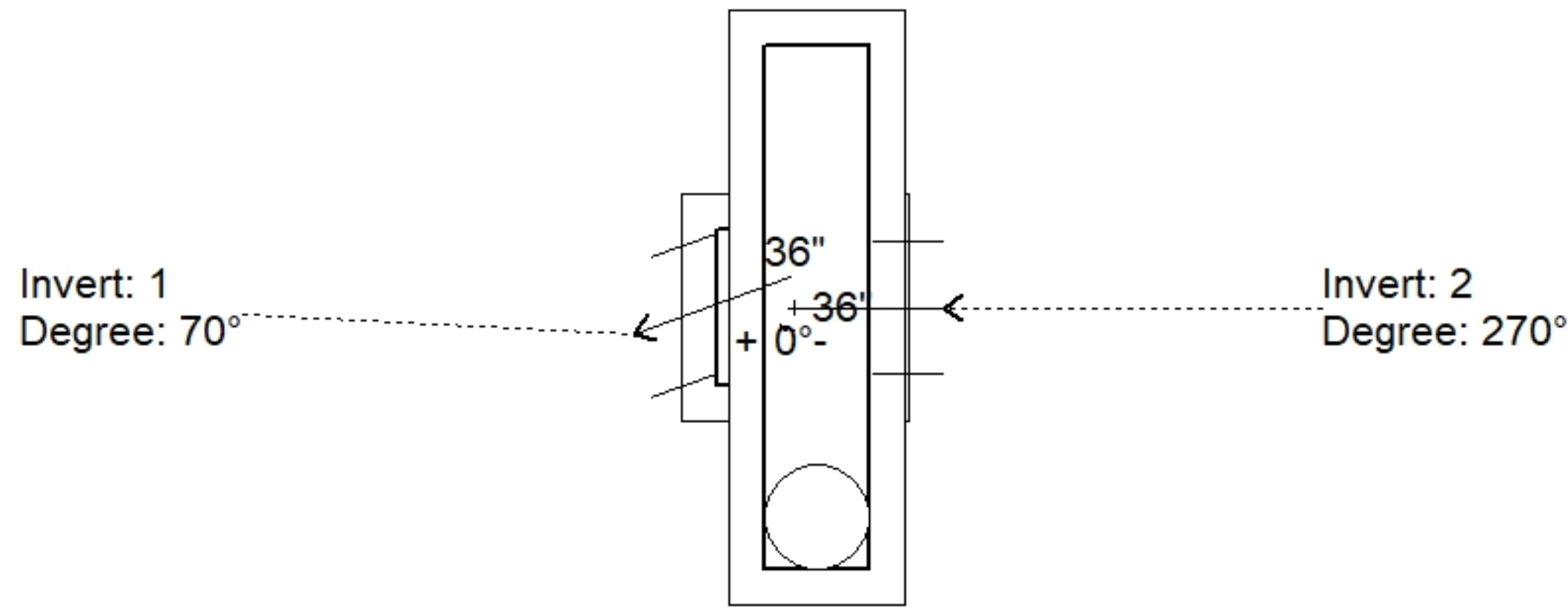

Position	Elev	Angle	Pipe	Pipe OD	Hole	Connector	Up ()	Ref
Rim	881.15'							
Reducer	876.04'							
Invert 1	871.04'	70°	24" HDPE	27.8"	30"	Hole 30	-3"	P1
Invert 2	871.04'	270°	24" HDPE	27.8"	30"	Hole 30	-3"	P1
Invert 3								
Invert 4								
Invert 5								
Invert 6								
Invert 7								
Invert 8								

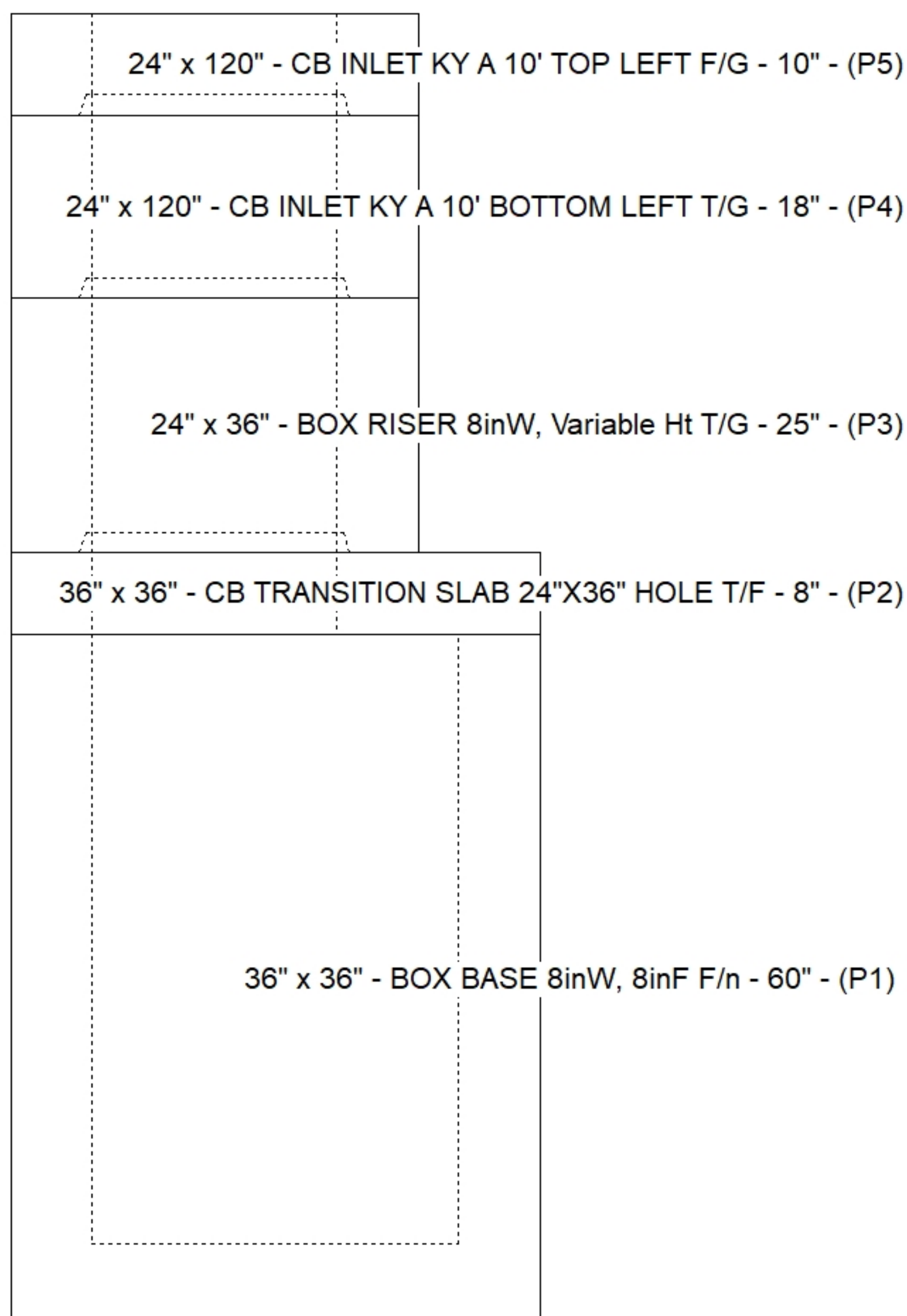

Cast (Int. Dim.) - Interior Dimensions

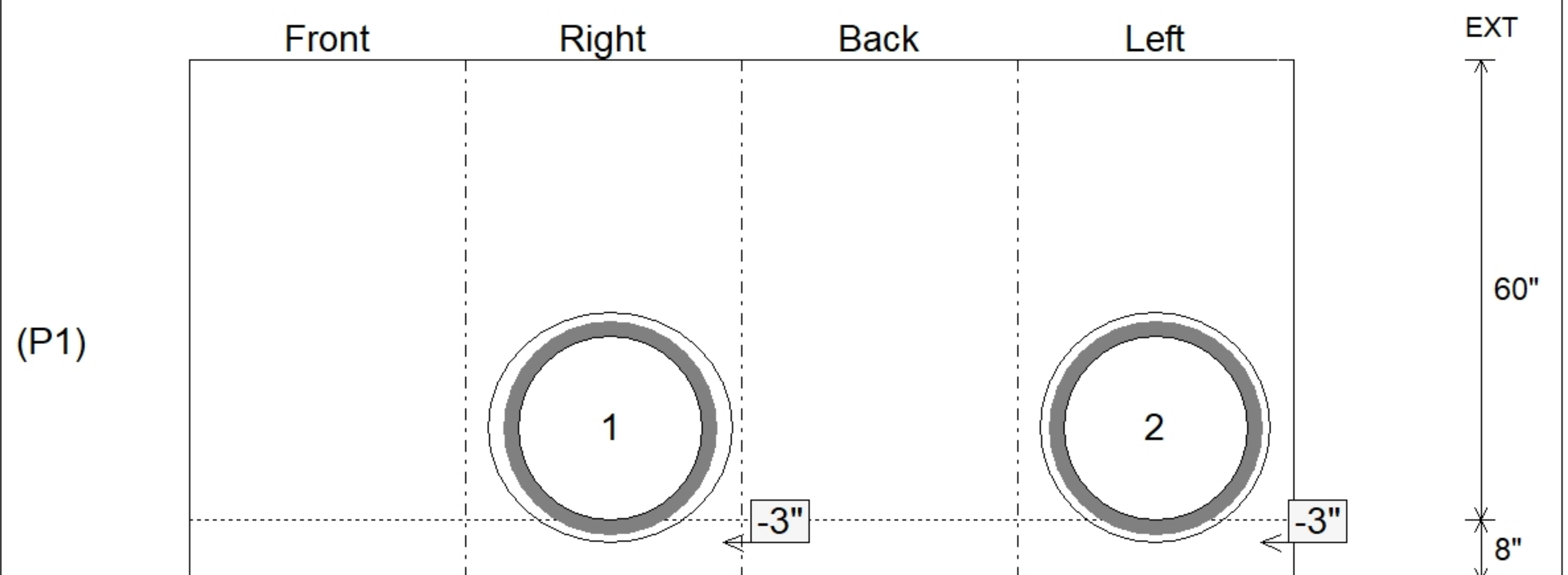

Submittal Drawing
 12/16/2025 4:34:48 PM

SUBMITTAL
 APPROVED BY: