

**Job Name: 25-1511 Halfhill Estates Ph.2**  
**Job Location: Nicholasville, KY**  
**Contractor: Perdue Environmental Contracting Co., Inc.**

PC: T. Ryan  
 TECH: J. Horsley  
 Plant: Beaver Dam



Structure ID: MH F-1  
 Spec: Sanitary  
 Type: SAN.MH w/Xypex  
 Size: 48"

Rim: 891.16'  
 Invert: 885.65'  
 Rim to Invert: 5.51'

Sump: 2"  
 Floor (Top): 885.483'  
 Floor Height: 6"

Floor (Bot): 884.983'  
 Overall Height: 6.083'  
 Slack: 1.12"

**Structure Notes:**

1. PER ASTM C478 SPECIFICATIONS.
2. CONCRETE = 4,000 PSI AT 28 DAYS.
3. CASTING SHIPPED LOOSE (HOE MC-350 F/C).

REINFORCING PER ASTM A615 (GRADE 60).  
 - CONE (As .12)  
 - RISER/WALLS (As .12)  
 - FLOOR (As .31) #5 BARS AT 12" C.C.E.W.

**STRUCTURE SUMMARY:**

P3) 24" - CASTING HEIGHT - 7"	0 lb
P2) 48" - ECC XYPEX CONE w/ 24" HOLE F/G - 36"	2251 lb
P1) 48" - MH BASE w/XYPEX T/n - 24"	2911 lb
1) 48" - SAN. INV. CHANNEL - FULL HEIGHT	1440 lb
1) JOINT WRAP - 0.065"x6"x50' CONSEAL CS212	0 lb
1) JOINT WRAP PRIMER - CONSEAL CS-75 (1 gal.)	0 lb
1) ADMIXTURE XYPEX C-500 NF RED	0 lb
1) CASTING - HOE MC-350 F/C Sanitary	305 lb
1) 48" - DBL 1"x14.5' Butyl (2x)	0 lb
2) PSX - 12-08 NYLO	16 lb
5) MH Step ML-10-TDS-NCR - 10"	0 lb
<b>Structure Total:</b>	<b>6923 lb</b>

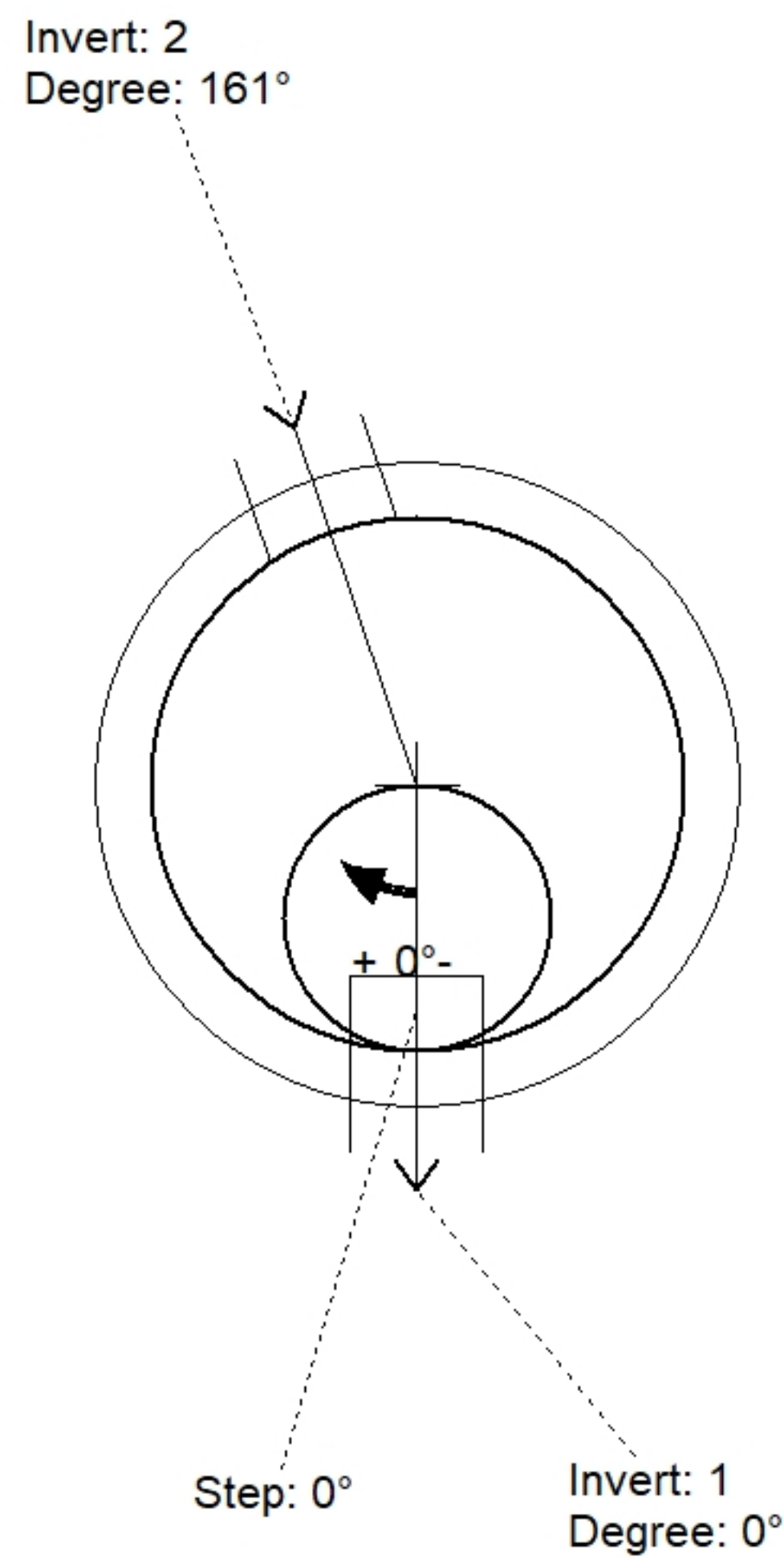

Position	Elev	Angle	Pipe	Pipe OD	Hole	Connector	Up (")	Ref
Rim	891.16'							
Reducer								
Invert 1	885.65'	0°	8" PVC SDR35	8.5"	12"	PSX 12-08 NYLO	0"	P1
Invert 2	885.75'	161°	8" PVC SDR35	8.5"	12"	PSX 12-08 NYLO	1.25"	P1
Invert 3								
Invert 4								
Invert 5								
Invert 6								
Invert 7								
Invert 8								

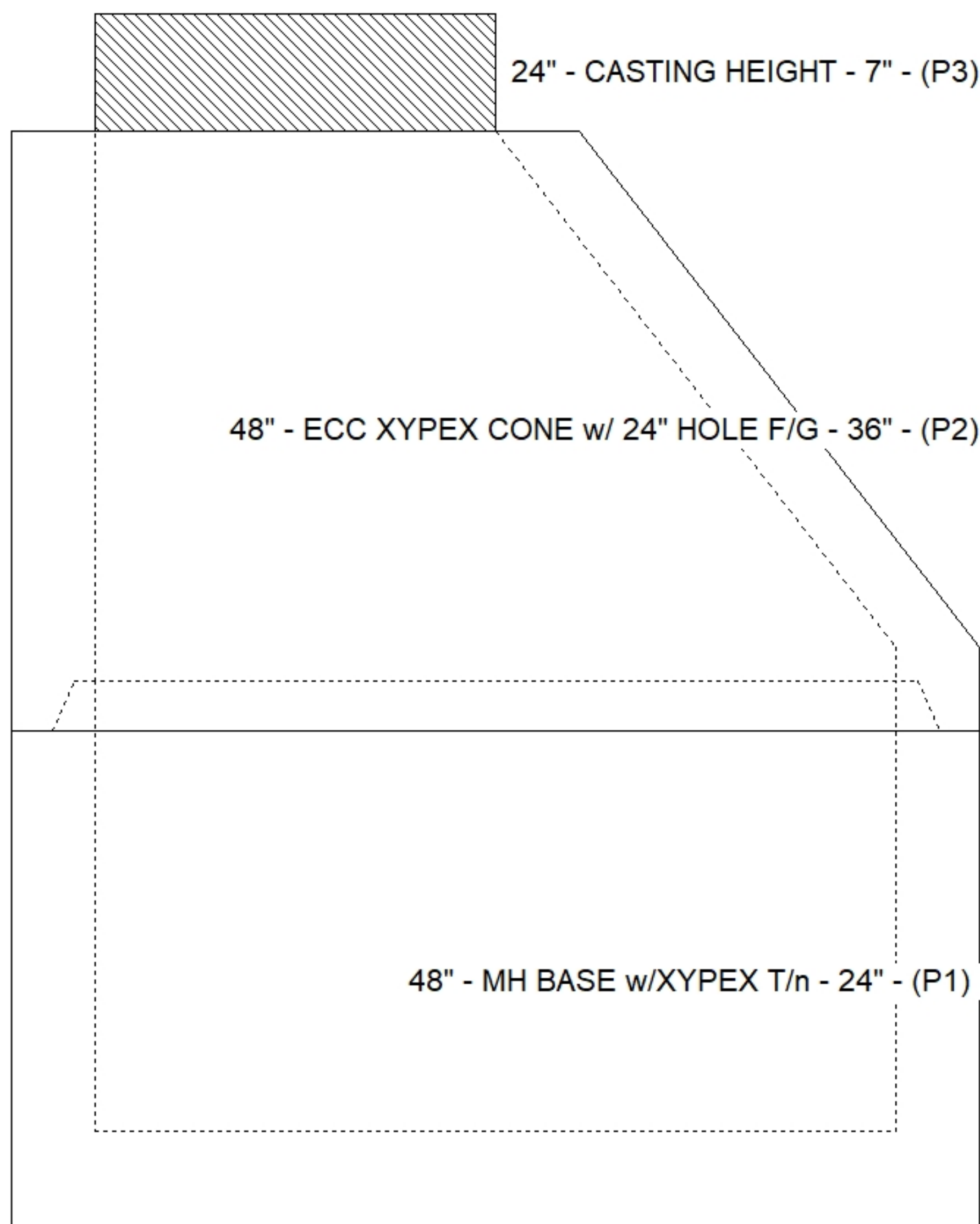

**Cast (Int. Dim.) - Interior Dimensions**

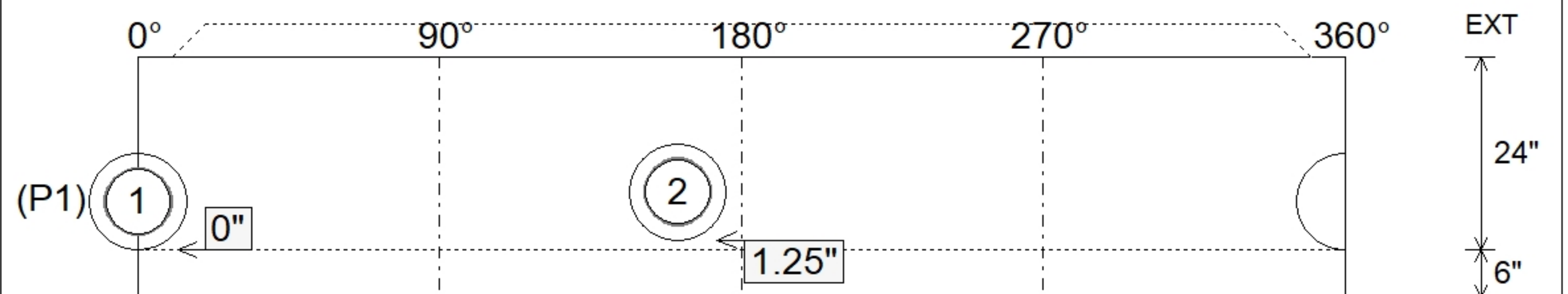

Submittal Drawing  
 11/11/2025 4:04:17 PM

SUBMITTAL  
 APPROVED BY: