

Job Name: 25-1511 Halfhill Estates Ph.2
Job Location: Nicholasville, KY
Contractor: Perdue Environmental Contracting Co., Inc.

PC: T. Ryan
 TECH: J. Horsley
 Plant: Beaver Dam



Structure ID: **MH A-9**
 Spec: Sanitary
 Type: SAN.MH w/Xypex
 Size: 48"

Rim: 885.19'
 Invert: 876.1'
 Rim to Invert: 9.09'

Sump: 2"
 Floor (Top): 875.933'
 Floor Height: 6"

Floor (Bot): 875.433'
 Overall Height: 9.583'
 Slack: 2.08"

Structure Notes:

1. PER ASTM C478 SPECIFICATIONS.
2. CONCRETE = 4,000 PSI AT 28 DAYS.
3. CASTING SHIPPED LOOSE (HOE MC-350 F/C).
4. SWEEP INVERT

REINFORCING PER ASTM A615 (GRADE 60).
 - CONE (As .12)
 - RISER/WALLS (As .12)
 - FLOOR (As .31) #5 BARS AT 12" C.C.E.W.

STRUCTURE SUMMARY:

P4) 24" - CASTING HEIGHT - 7"	0 lb
P3) 48" - ECC XYPEX CONE w/ 24" HOLE F/G - 36"	2251 lb
P2) 48" - MH RISER w/XYPEX T/G - 24"	1677 lb
P1) 48" - MH BASE w/XYPEX T/n - 42"	4121 lb
1) 48" - SAN. INV. CHANNEL - FULL HEIGHT	1440 lb
1) JOINT WRAP - 0.065"x6"x50' CONSEAL CS212	0 lb
1) JOINT WRAP PRIMER - CONSEAL CS-75 (1 gal.)	0 lb
1) ADMIXTURE XYPEX C-500 NF RED	0 lb
1) CASTING - HOE MC-350 F/C Sanitary	305 lb
2) 48" - DBL 1"x14.5' Butyl (2x)	0 lb
3) PSX - 12-08 NYLO	24 lb
8) MH Step ML-10-TDS-NCR - 10"	0 lb
Structure Total:	9817 lb

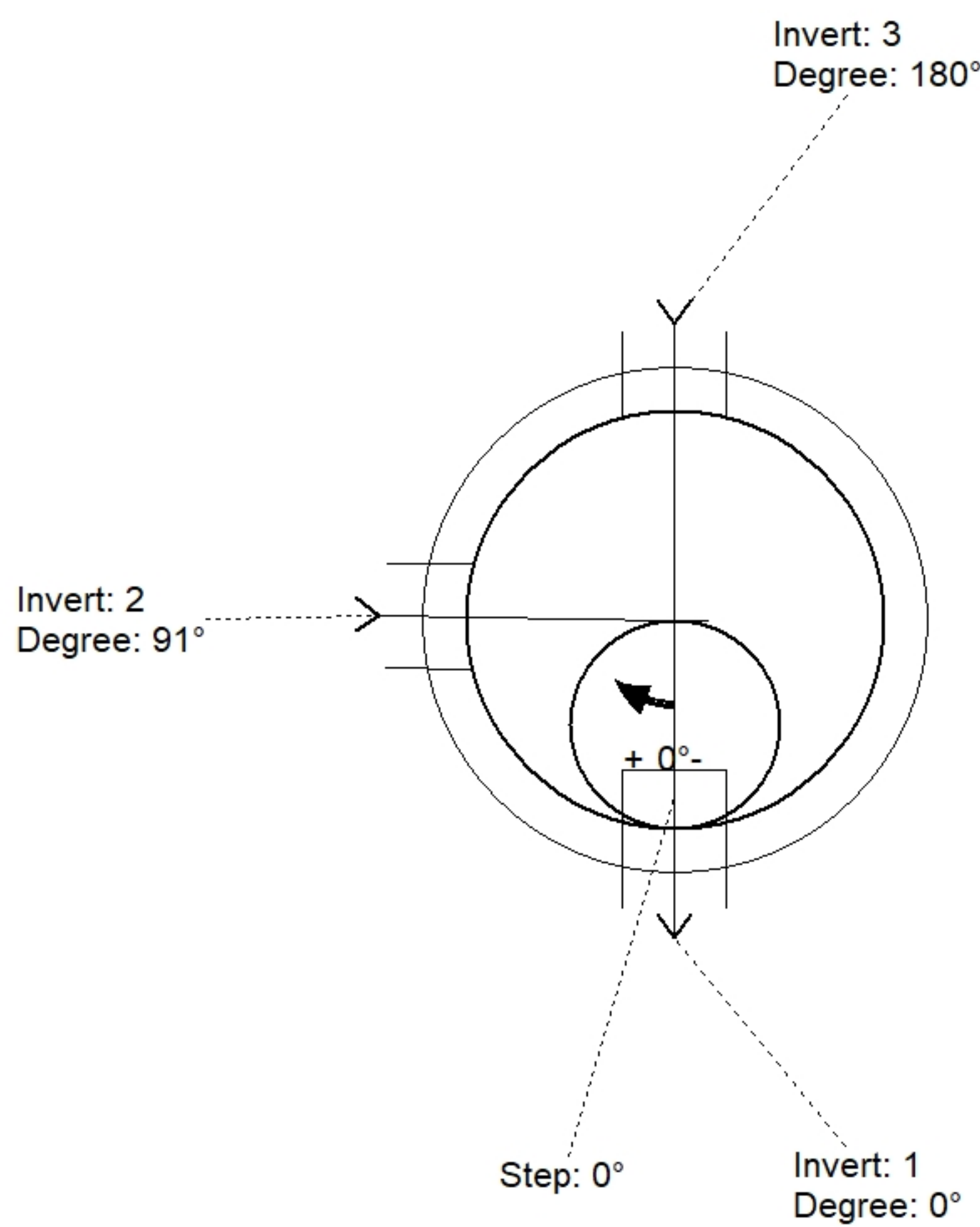

Position	Elev	Angle	Pipe	Pipe OD	Hole	Connector	Up (")	Ref
Rim	885.19'							
Reducer								
Invert 1	876.1'	0°	8" PVC SDR35	8.5"	12"	PSX 12-08 NYLO	0"	P1
Invert 2	876.2'	91°	8" PVC SDR35	8.5"	12"	PSX 12-08 NYLO	1.25"	P1
Invert 3	878.12'	180°	8" PVC SDR35	8.5"	12"	PSX 12-08 NYLO	24.25"	P1
Invert 4								
Invert 5								
Invert 6								
Invert 7								
Invert 8								

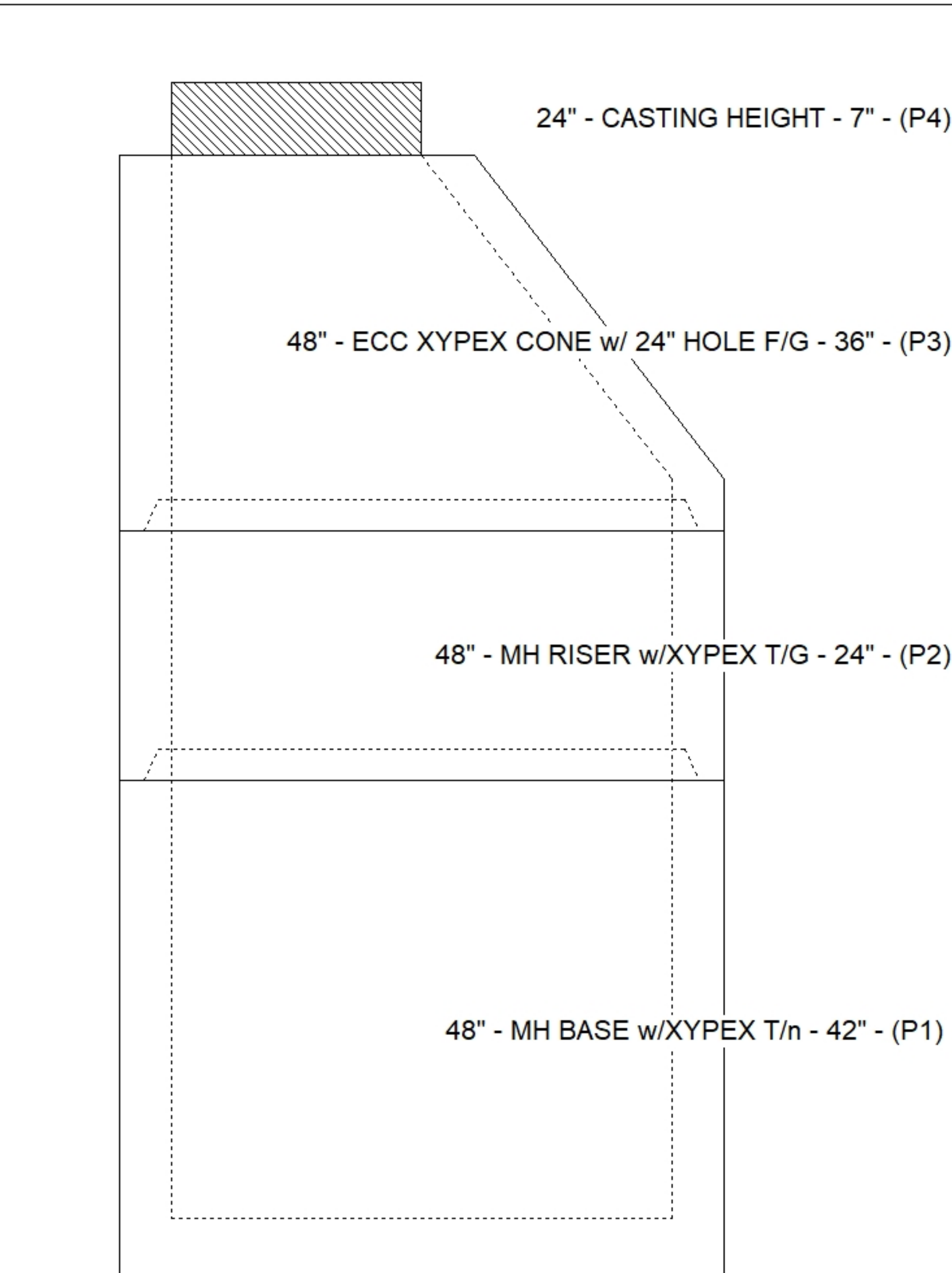

Cast (Int. Dim.) - Interior Dimensions

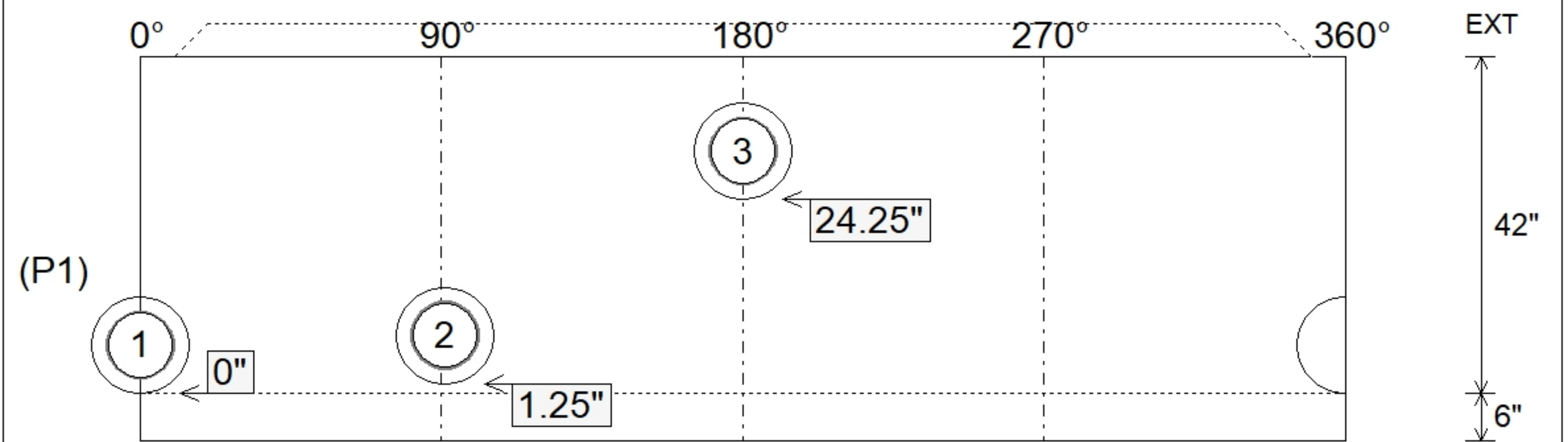

Submittal Drawing
 11/11/2025 4:04:15 PM

SUBMITTAL
 APPROVED BY: