

Job Name: 25-1511 Halfhill Estates Ph.2
 Job Location: Nicholasville, KY
 Contractor: Perdue Environmental Contracting Co., Inc.

Plant: Beaver Dam
 11/11/2025 4:05:05 PM

Tech: J. Horsley
 PC: T. Ryan



Structure ID: MH A-9

P1 MH048BA42X

MH BASE w/XYPEX T/n

P4) 24" - CASTING HEIGHT - 7"	0 lb
P3) 48" - ECC XYPEX CONE w/ 24" HOLE F/G - 36"	2251 lb
P2) 48" - MH RISER w/XYPEX T/G - 24"	1677 lb
P1) 48" - MH BASE w/XYPEX T/n - 42"	4121 lb
1) 48" - SAN. INV. CHANNEL - FULL HEIGHT	1440 lb
1) JOINT WRAP - 0.065"x6"x50' CONSEAL CS212	0 lb
1) JOINT WRAP PRIMER - CONSEAL CS-75 (1 gal.)	0 lb
1) ADMIXTURE XYPEX C-500 NF RED	0 lb
1) CASTING - HOE MC-350 F/C Sanitary	305 lb
2) 48" - DBL 1"x14.5' Butyl (2x)	0 lb
3) PSX - 12-08 NYLO	24 lb
8) MH Step ML-10-TDS-NCR - 10"	0 lb
Structure Total:	9817 lb

Structure Notes:
 1. PER ASTM C478 SPECIFICATIONS.
 2. CONCRETE = 4,000 PSI AT 28 DAYS.
 3. CASTING SHIPPED LOOSE (HOE MC-350 F/C).
 4. SWEEP INVERT

REINFORCING PER ASTM A615 (GRADE 60).
 - CONE (As .12)
 - RISER/WALLS (As .12)
 - FLOOR (As .31) #5 BARS AT 12" C.C.E.W.

Rim: 885.19' Rim to Invert: 9.09' Slack: 2.08" Sump: 2" Step Position: 0°

Position	Elev	Angle	Ext. (cw)	Pipe	Pipe OD	Connector	Hole	Horz Size	Up ()	Offset
Invert 1	876.1'	0°	0"	8" PVC SDR35	8.5"	PSX 12-08 NYLO	12"	12.129"	0"	0"
Invert 2	876.2'	91°	46"	8" PVC SDR35	8.5"	PSX 12-08 NYLO	12"	12.129"	1.25"	0"
Invert 3	878.12'	180°	91.125"	8" PVC SDR35	8.5"	PSX 12-08 NYLO	12"	12.129"	24.25"	0"
Invert 4										
Invert 5										
Invert 6										
Invert 7										
Invert 8										

RIGHT-SIDE UP VIEW (int. dimensions)

UPSIDE-DOWN VIEW (int. dimensions)

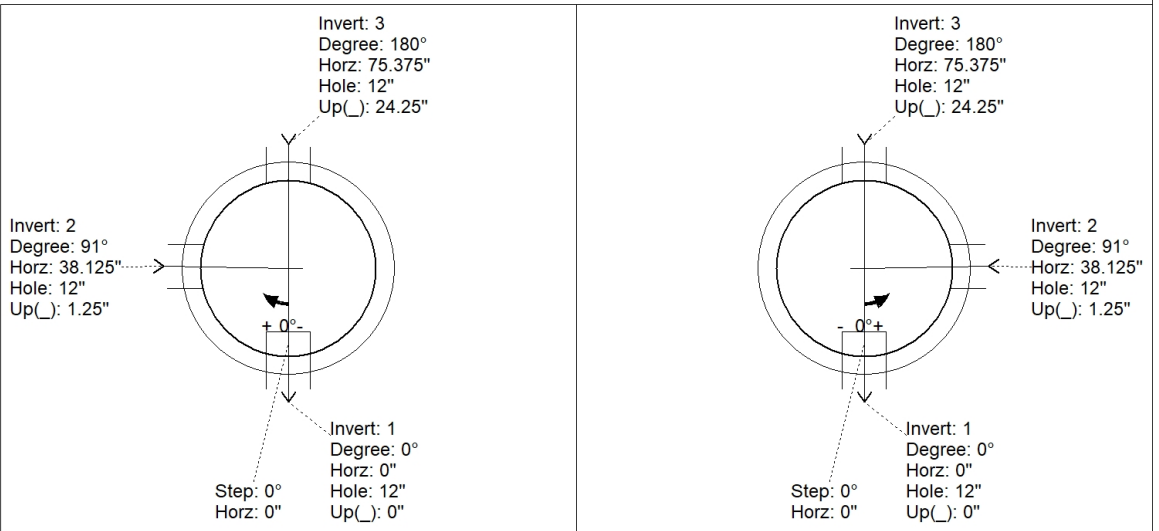

INSIDE WALL DIMENSIONS

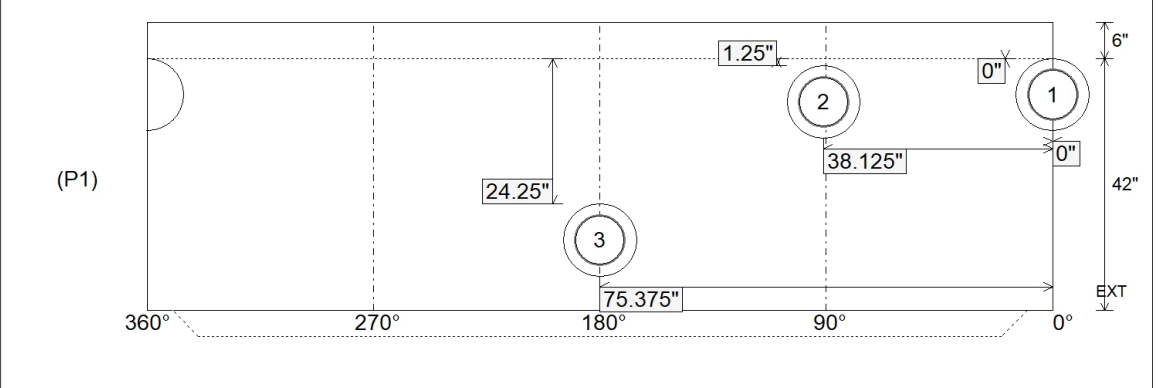

Coating (Int): Coating (Ext):	Seam Up: Tongue Seam Dn: n/a	Wall Thickness: 5" Floor Height: 6"	Height (Int): 42" Height (Ext): 48"	Weight (Net): 4121 lb Volume (Net): 1.05cu.yd
----------------------------------	---------------------------------	--	--	--

Job Name: 25-1511 Halfhill Estates Ph.2
 Job Location: Nicholasville, KY
 Contractor: Perdue Environmental Contracting Co., Inc.

Plant: Beaver Dam
 11/11/2025 4:05:05 PM

Tech: J. Horsley
 PC: T. Ryan



Structure ID: MH A-9

P1A MH048BA42X

MH BASE w/XYPEX T/n

P4) 24" - CASTING HEIGHT - 7"	0 lb
P3) 48" - ECC XYPEX CONE w/ 24" HOLE F/G - 36"	2251 lb
P2) 48" - MH RISER w/XYPEX T/G - 24"	1677 lb
P1) 48" - MH BASE w/XYPEX T/n - 42"	4121 lb
1) 48" - SAN. INV. CHANNEL - FULL HEIGHT	1440 lb
1) JOINT WRAP - 0.065"x6"x50' CONSEAL CS212	0 lb
1) JOINT WRAP PRIMER - CONSEAL CS-75 (1 gal.)	0 lb
1) ADMIXTURE XYPEX C-500 NF RED	0 lb
1) CASTING - HOE MC-350 F/C Sanitary	305 lb
2) 48" - DBL 1"x14.5' Butyl (2x)	0 lb
3) PSX - 12-08 NYLO	24 lb
8) MH Step ML-10-TDS-NCR - 10"	0 lb
Structure Total:	9817 lb

Structure Notes:
 1. PER ASTM C478 SPECIFICATIONS.
 2. CONCRETE = 4,000 PSI AT 28 DAYS.
 3. CASTING SHIPPED LOOSE (HOE MC-350 F/C).
 4. SWEEP INVERT

REINFORCING PER ASTM A615 (GRADE 60).
 - CONE (As .12)
 - RISER/WALLS (As .12)
 - FLOOR (As .31) #5 BARS AT 12" C.C.E.W.

Rim: 885.19' Rim to Invert: 9.09' Slack: 2.08" Sump: 2" Step Position: 0°

Position	Elev	Angle	Ext. (cw)	Pipe	Pipe OD	Connector	Hole	Horz Size	Up ()	Offset
Invert 1	876.1'	0°	0"	8" PVC SDR35	8.5"	PSX 12-08 NYLO	12"	12.129"	0"	0"
Invert 2	876.2'	91°	46"	8" PVC SDR35	8.5"	PSX 12-08 NYLO	12"	12.129"	1.25"	0"
Invert 3	878.12'	180°	91.125"	8" PVC SDR35	8.5"	PSX 12-08 NYLO	12"	12.129"	24.25"	0"
Invert 4										
Invert 5										
Invert 6										
Invert 7										
Invert 8										

RIGHT-SIDE UP VIEW (int. dimensions)

UPSIDE-DOWN VIEW (int. dimensions)

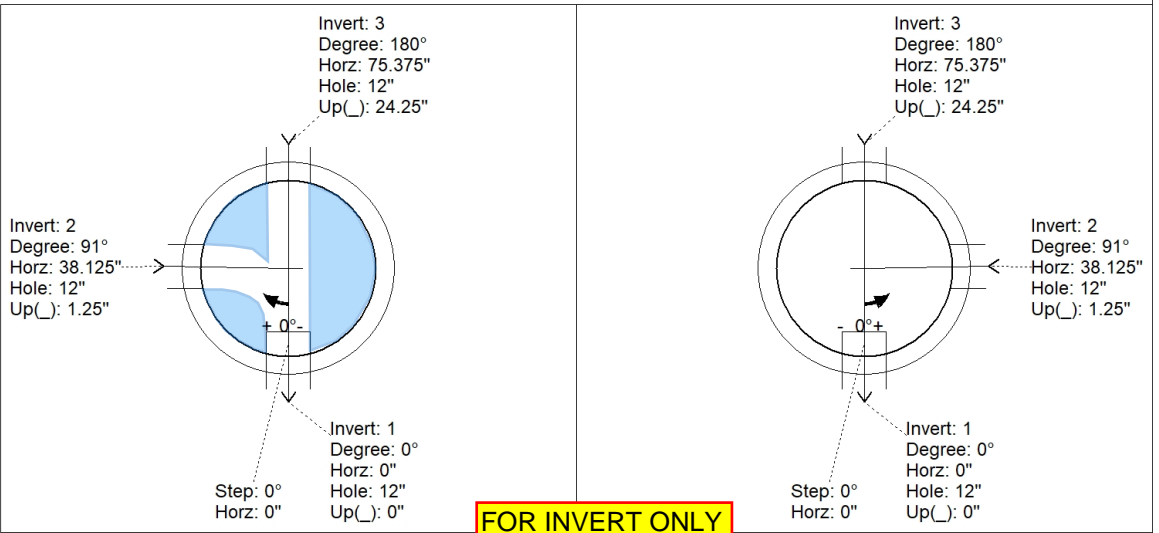

FOR INVERT ONLY

INSIDE WALL DIMENSIONS

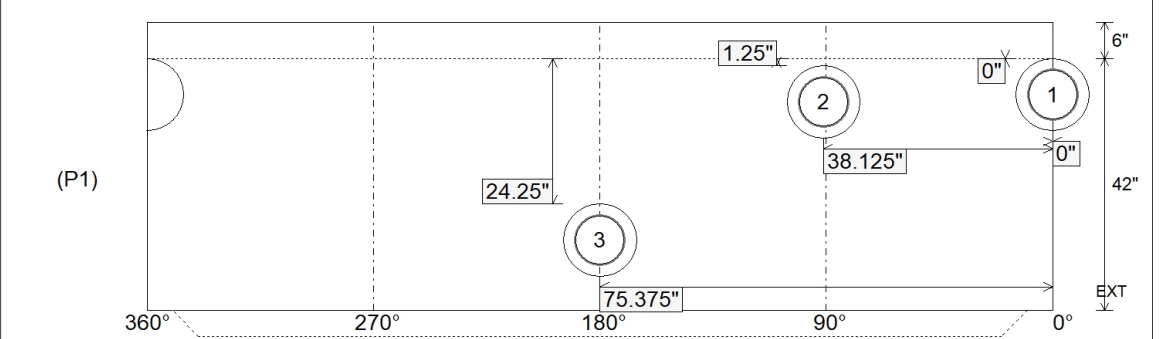

Coating (Int): Coating (Ext):	Seam Up: Tongue Seam Dn: n/a	Wall Thickness: 5" Floor Height: 6"	Height (Int): 42" Height (Ext): 48"	Weight (Net): 4121 lb Volume (Net): 1.05cu.yd
----------------------------------	---------------------------------	--	--	--