

Job Name: 25-1511 Halfhill Estates Ph.2
 Job Location: Nicholasville, KY
 Contractor: Perdue Environmental Contracting Co., Inc.

Plant: Beaver Dam
 11/11/2025 4:05:06 PM

Tech: J. Horsley
 PC: T. Ryan



Structure ID: MH A-11

P1 MH048BA24X

MH BASE w/XYPEX T/n

P3) 24" - CASTING HEIGHT - 7"	0 lb
P2) 48" - ECC XYPEX CONE w/ 24" HOLE F/G - 30"	1981 lb
P1) 48" - MH BASE w/XYPEX T/n - 24"	2959 lb
1) 48" - SAN. INV. CHANNEL - FULL HEIGHT	1440 lb
1) JOINT WRAP - 0.065"x6"x50' CONSEAL CS212	0 lb
1) JOINT WRAP PRIMER - CONSEAL CS-75 (1 gal.)	0 lb
1) ADMIXTURE XYPEX C-500 NF RED	0 lb
1) CASTING - HOE MC-350 F/C Sanitary	305 lb
1) 48" - DBL 1"x14.5' Butyl (2x)	0 lb
1) PSX - 12-08 NYLO	8 lb
5) MH Step ML-10-TDS-NCR - 10"	0 lb
Structure Total:	6693 lb

Structure Notes:
 1. PER ASTM C478 SPECIFICATIONS.
 2. CONCRETE = 4,000 PSI AT 28 DAYS.
 3. CASTING SHIPPED LOOSE (HOE MC-350 F/C).

 REINFORCING PER ASTM A615 (GRADE 60).
 - CONE (As .12)
 - RISER/WALLS (As .12)
 - FLOOR (As .31) #5 BARS AT 12" C.C.E.W.

Rim: 891.89' Rim to Invert: 4.97' Slack: 0.64" Sump: 2" Step Position: 0°

Position	Elev	Angle	Ext. (cw)	Pipe	Pipe OD	Connector	Hole	Horz Size	Up ()	Offset
Invert 1	886.92'	0°	0"	8" PVC SDR35	8.5"	PSX 12-08 NYLO	12"	12.129"	0"	0"
Invert 2										
Invert 3										
Invert 4										
Invert 5										
Invert 6										
Invert 7										
Invert 8										

RIGHT-SIDE UP VIEW (int. dimensions)

UPSIDE-DOWN VIEW (int. dimensions)

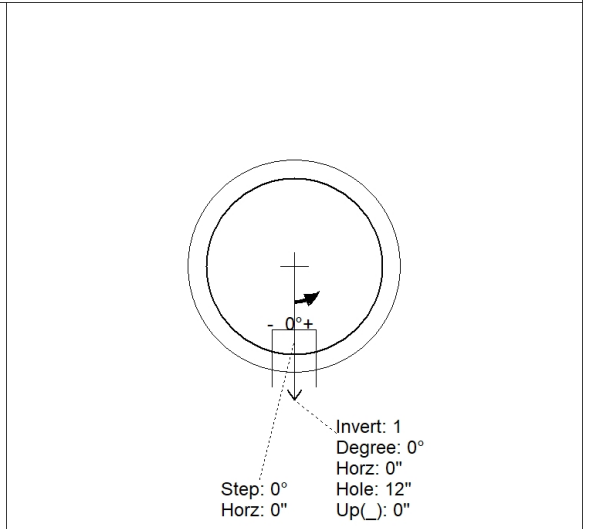
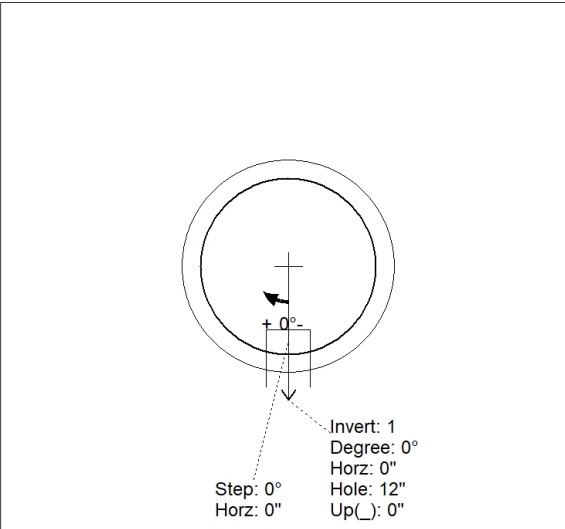
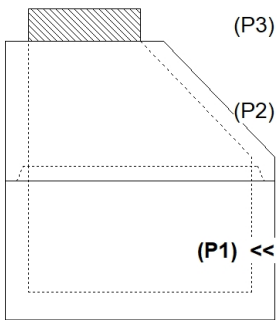

INSIDE WALL DIMENSIONS

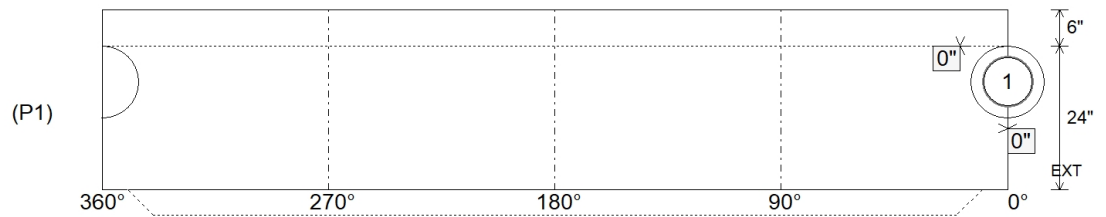

Coating (Int):
 Coating (Ext):

Seam Up: Tongue
 Seam Dn: n/a

Wall Thickness: 5"
 Floor Height: 6"

Height (Int): 24"
 Height (Ext): 30"

Weight (Net): 2959 lb
 Volume (Net): 0.76cu.yd

Job Name: 25-1511 Halfhill Estates Ph.2
 Job Location: Nicholasville, KY
 Contractor: Perdue Environmental Contracting Co., Inc.

Plant: Beaver Dam

Tech: J. Horsley

11/11/2025 4:05:06 PM

PC: T. Ryan



Structure ID: MH A-11

P1A MH048BA24X

MH BASE w/XYPEX T/n

P3) 24" - CASTING HEIGHT - 7"	0 lb
P2) 48" - ECC XYPEX CONE w/ 24" HOLE F/G - 30"	1981 lb
P1) 48" - MH BASE w/XYPEX T/n - 24"	2959 lb
1) 48" - SAN. INV. CHANNEL - FULL HEIGHT	1440 lb
1) JOINT WRAP - 0.065"x6"x50' CONSEAL CS212	0 lb
1) JOINT WRAP PRIMER - CONSEAL CS-75 (1 gal.)	0 lb
1) ADMIXTURE XYPEX C-500 NF RED	0 lb
1) CASTING - HOE MC-350 F/C Sanitary	305 lb
1) 48" - DBL 1"x14.5' Butyl (2x)	0 lb
1) PSX - 12-08 NYLO	8 lb
5) MH Step ML-10-TDS-NCR - 10"	0 lb
Structure Total:	6693 lb

Structure Notes:
 1. PER ASTM C478 SPECIFICATIONS.
 2. CONCRETE = 4,000 PSI AT 28 DAYS.
 3. CASTING SHIPPED LOOSE (HOE MC-350 F/C).

 REINFORCING PER ASTM A615 (GRADE 60).
 - CONE (As .12)
 - RISER/WALLS (As .12)
 - FLOOR (As .31) #5 BARS AT 12" C.C.E.W.

Rim: 891.89' Rim to Invert: 4.97' Slack: 0.64" Sump: 2" Step Position: 0°

Position	Elev	Angle	Ext. (cw)	Pipe	Pipe OD	Connector	Hole	Horz Size	Up ()	Offset
Invert 1	886.92'	0°	0"	8" PVC SDR35	8.5"	PSX 12-08 NYLO	12"	12.129"	0"	0"
Invert 2										
Invert 3										
Invert 4										
Invert 5										
Invert 6										
Invert 7										
Invert 8										

RIGHT-SIDE UP VIEW (int. dimensions)

UPSIDE-DOWN VIEW (int. dimensions)

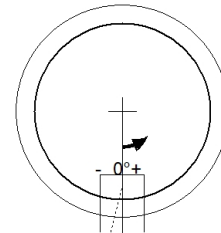
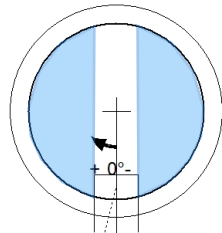
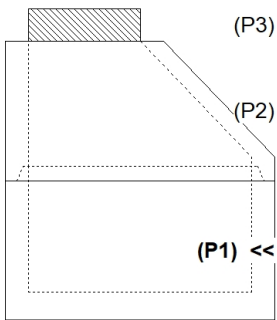

FOR INVERT ONLY

INSIDE WALL DIMENSIONS

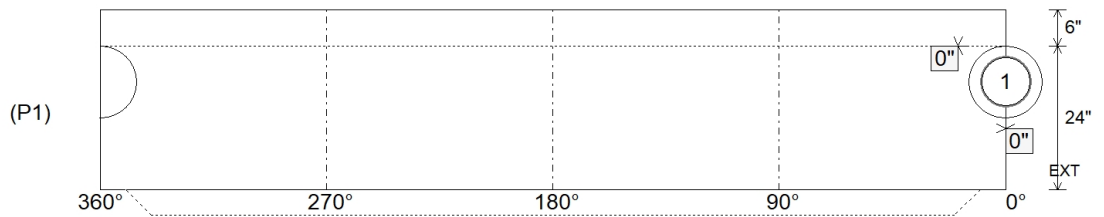

Coating (Int):
 Coating (Ext):

Seam Up: Tongue
 Seam Dn: n/a

Wall Thickness: 5"
 Floor Height: 6"

Height (Int): 24"
 Height (Ext): 30"

Weight (Net): 2959 lb
 Volume (Net): 0.76cu.yd