

Job Name: 25-1431 - Georgetown Commons  
 Job Location: Georgetown, KY  
 Contractor: Winwater Hartford KY Co.

Plant: Beaver Dam  
 4/24/2026 2:18:07 PM

Tech: J. Coppage  
 PC: A. Chambers



**Structure ID: YD 72**

**P1 MH048BA48**

**MH BASE**

- P4) 24" x 24" - CASTING HEIGHT - 4"
- P3) 24" x 24" - GRADE RING - 4"
- P2) 48" - MH FLAT TOP w/24"x24" Hole - 12"
- P1) 48" - MH BASE - 48"
- 1) CASTING - HOE 280T F/G
- 1) 48" - Conseal CS-102 1.00"
- 2) 24" x 24" - Conseal CS-102 1.00"
- 1) Hole - 12
- 4) MH Step ML-10-TDS-NCR - 10"

- Structure Notes:**
1. JR HOE HOE-280T PROVIDED BY ICAST.
  2. PER ASTM C478 SPECIFICATIONS.
  3. CONCRETE = 4,000 PSI AT 28 DAYS.
  4. REINFORCING PER ASTM A615 (GRADE 60).  
 - TOP SLAB (As .62) #5 BARS AT 6" C.C.E.W..  
 - RISER/WALLS (As .12)  
 - FLOOR (As .31) #5 BARS AT 12" C.C.E.W.

Structure Total: 6661 lb

Rim: 867.75' Rim to Invert: 5.75' Slack: 1.55' Sump: 0.55' Step Position: 180°

Position	Elev	Angle	Ext. (cw)	Pipe	Pipe OD	Connector	Hole	Horz Size	Up ( )	Offset
Invert 1	862'	0°	0"	8" HDPE	9.1"	Hole 12	12"	12.129"	0"	0"
Invert 2										
Invert 3										
Invert 4										
Invert 5										
Invert 6										
Invert 7										
Invert 8										

RIGHT-SIDE UP VIEW (int. dimensions)

UPSIDE-DOWN VIEW (int. dimensions)

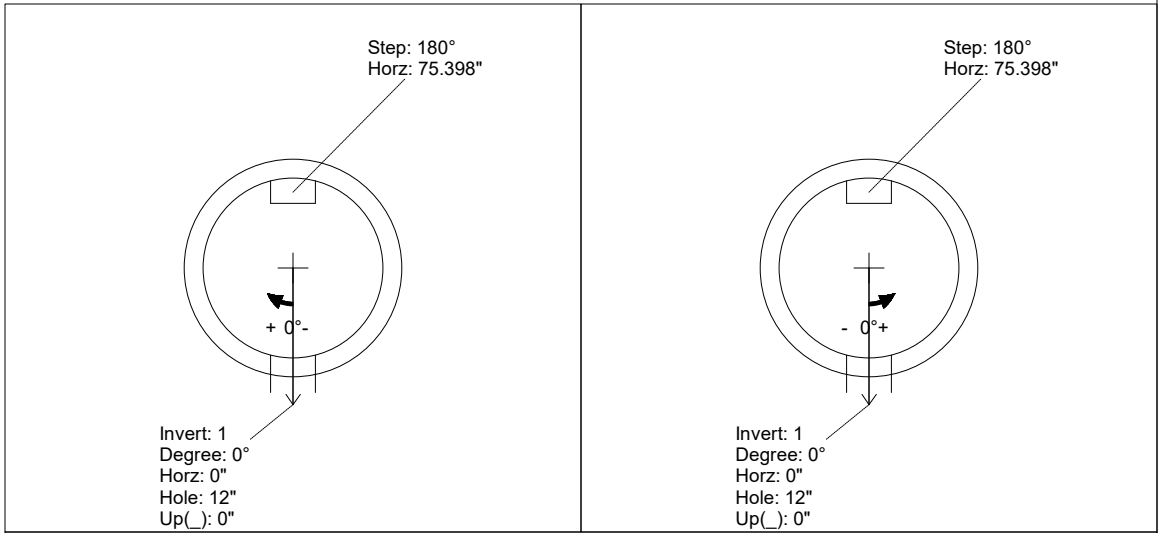
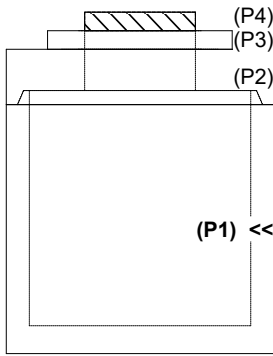

INSIDE WALL DIMENSIONS

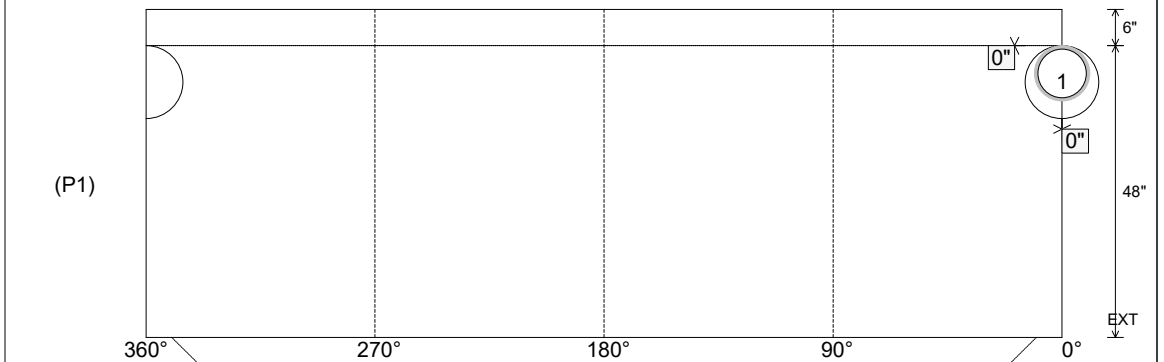

Coating (Int):  
 Coating (Ext):

Seam Up: Tongue  
 Seam Dn: n/a

Wall Thickness: 5"  
 Floor Height: 6"

Height (Int): 48"  
 Height (Ext): 54"

Weight (Net): 4636 lb  
 Volume (Net): 1.18cu.yd