

Job Name: 25-1431 - Georgetown Commons  
 Job Location: Georgetown, KY  
 Contractor: Winwater Hartford KY Co.

Plant: Beaver Dam

4/28/2026 8:55:48 AM

Tech: J. Coppage

PC: A. Chambers



**Structure ID: SSMH-42**

**P1 MH048BA30**

**MH BASE**

- P4) 24" - CASTING HEIGHT - 7"
- P3) 48" - ECC CONE w/ 24" HOLE NO STEP - 24"
- P2) 48" - MH RISER NO STEPS - 36"
- P1) 48" - MH BASE - 30"
- 1) JOINT WRAP - 0.065"x6"x50' CONSEAL CS212
- 1) JOINT WRAP PRIMER - CONSEAL CS-75 (1 gal.)
- 1) 48" - MH INVERT CHANNEL - FULL HEIGHT
- 2) 48" - Conseal CS-102 1.00" (Double)
- 2) A-Lok - 0285

- Structure Notes:**
1. JR HOE MC-375 SELF SEALING SAN BY ICAST
  2. PER ASTM C478 SPECIFICATIONS.
  3. CONCRETE = 4,000 PSI AT 28 DAYS.
  4. REINFORCING PER ASTM A615 (GRADE 60).  
 - CONE (As .12)  
 - RISER/WALLS (As .12)  
 - FLOOR (As .31) #5 BARS AT 12" C.C.E.W.
  5. \*\*NO STEPS\*\*

Structure Total: 8870 lb

Rim: 867.48' Rim to Invert: 8.08' Slack: 1.96" Sump: 2" Step Position:

Position	Elev	Angle	Ext. (cw)	Pipe	Pipe OD	Connector	Hole	Horz Size	Up ( )	Offset
Invert 1	859.4'	0°	0"	8" PVC SDR35	8.5"	A-Lok 0285	9.75"	9.818"	1.125"	0"
Invert 2	859.5'	201°	101.735"	8" PVC SDR35	8.5"	A-Lok 0285	9.75"	9.818"	2.325"	0"
Invert 3										
Invert 4										
Invert 5										
Invert 6										
Invert 7										
Invert 8										

RIGHT-SIDE UP VIEW (int. dimensions)

UPSIDE-DOWN VIEW (int. dimensions)

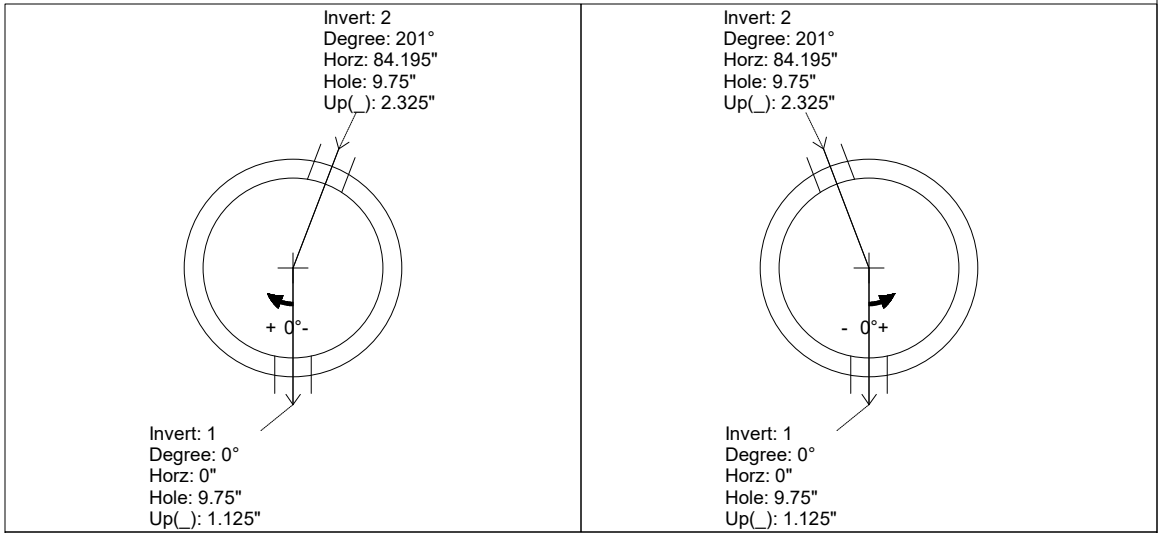
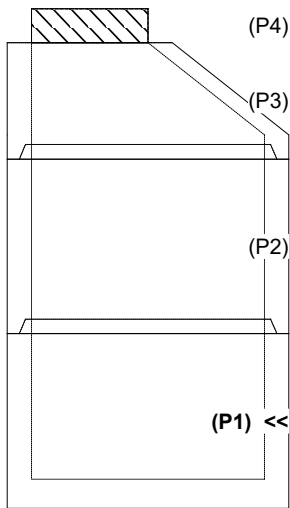

INSIDE WALL DIMENSIONS

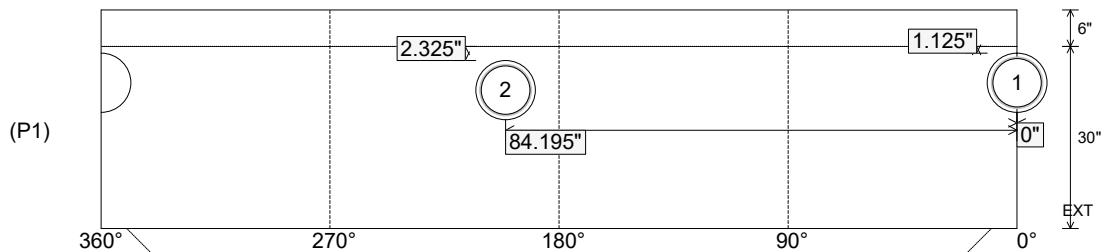

Coating (Int):  
 Coating (Ext):

Seam Up: Tongue  
 Seam Dn: n/a

Wall Thickness: 5"  
 Floor Height: 6"

Height (Int): 30"  
 Height (Ext): 36"

Weight (Net): 3363 lb  
 Volume (Net): 0.86cu.yd

Job Name: 25-1431 - Georgetown Commons  
 Job Location: Georgetown, KY  
 Contractor: Winwater Hartford KY Co.

Plant: Beaver Dam

4/28/2026 8:55:48 AM

Tech: J. Coppage

PC: A. Chambers



**Structure ID: SSMH-42**

**P1 MH048BA30**

**MH BASE**

- P4) 24" - CASTING HEIGHT - 7"
- P3) 48" - ECC CONE w/ 24" HOLE NO STEP - 24"
- P2) 48" - MH RISER NO STEPS - 36"
- P1) 48" - MH BASE - 30"
- 1) JOINT WRAP - 0.065"x6"x50' CONSEAL CS212
- 1) JOINT WRAP PRIMER - CONSEAL CS-75 (1 gal.)
- 1) 48" - MH INVERT CHANNEL - FULL HEIGHT
- 2) 48" - Conseal CS-102 1.00" (Double)
- 2) A-Lok - 0285

- Structure Notes:**
1. JR HOE MC-375 SELF SEALING SAN BY ICAST
  2. PER ASTM C478 SPECIFICATIONS.
  3. CONCRETE = 4,000 PSI AT 28 DAYS.
  4. REINFORCING PER ASTM A615 (GRADE 60).  
 - CONE (As .12)  
 - RISER/WALLS (As .12)  
 - FLOOR (As .31) #5 BARS AT 12" C.C.E.W.
  5. \*\*NO STEPS\*\*

Structure Total: 8870 lb

**INVERT CHANNEL DRAWING  
 FULL HEIGHT INVERT**

Rim: 867.48' Rim to Invert: 8.08' Slack: 1.96" Sump: 2" Step Position:

Position	Elev	Angle	Ext. (cw)	Pipe	Pipe OD	Connector	Hole	Horz Size	Up (")	Offset
Invert 1	859.4'	0°	0"	8" PVC SDR35	8.5"	A-Lok 0285	9.75"	9.818"	1.125"	0"
Invert 2	859.5'	201°	101.735"	8" PVC SDR35	8.5"	A-Lok 0285	9.75"	9.818"	2.325"	0"
Invert 3										
Invert 4										
Invert 5										
Invert 6										
Invert 7										
Invert 8										

RIGHT-SIDE UP VIEW (int. dimensions)

UPSIDE-DOWN VIEW (int. dimensions)

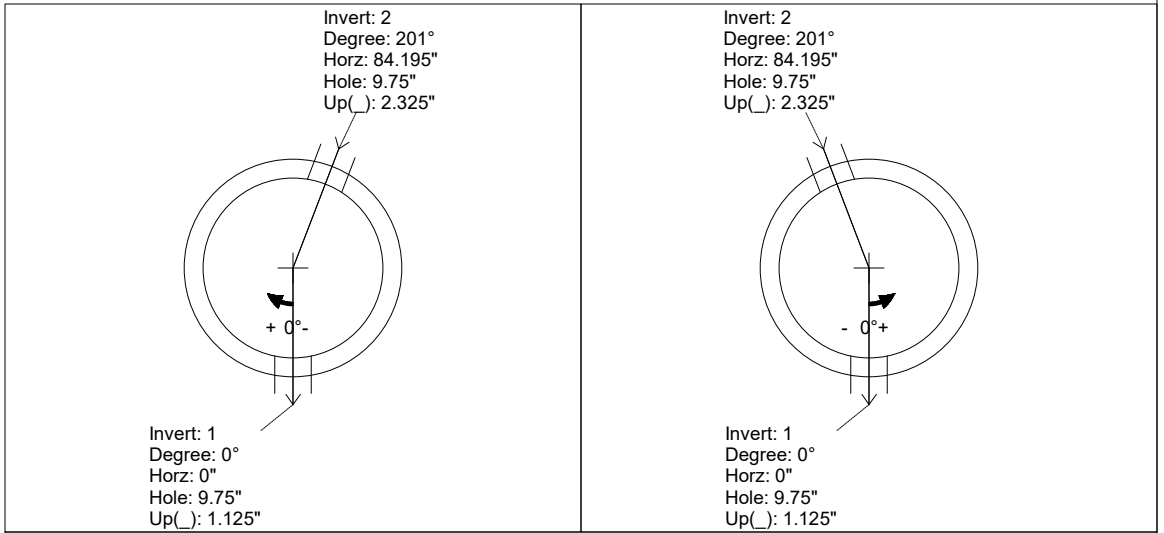
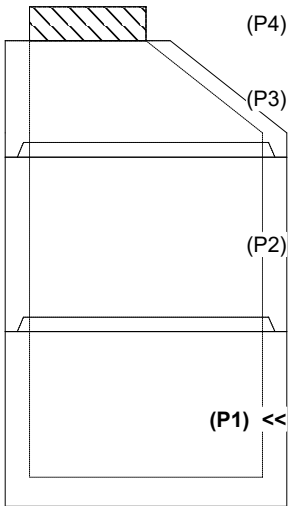

INSIDE WALL DIMENSIONS

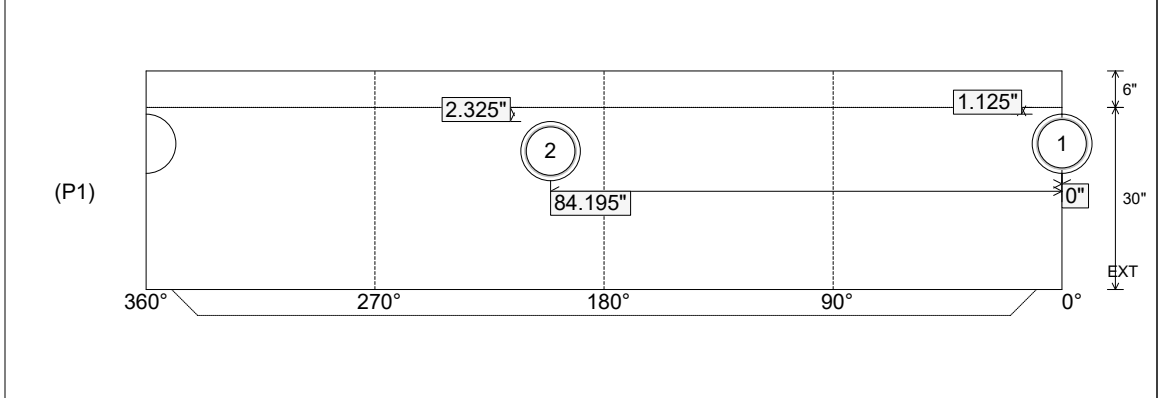

Coating (Int): Coating (Ext):	Seam Up: Tongue Seam Dn: n/a	Wall Thickness: 5" Floor Height: 6"	Height (Int): 30" Height (Ext): 36"	Weight (Net): 3363 lb Volume (Net): 0.86cu.yd
----------------------------------	---------------------------------	--	--	--