

Job Name: 25-1431 - Georgetown Commons  
 Job Location: Georgetown, KY  
 Contractor: Winwater Hartford KY Co.

Plant: Beaver Dam

Tech: J. Coppage

4/28/2026 8:55:49 AM

PC: A. Chambers



**Structure ID: SSMH-41**

**P1 MH048BA36**

**MH BASE**

- P4) 24" - CASTING HEIGHT - 7"
- P3) 24" - GRADE RING - 3"
- P2) 48" - ECC CONE w/ 24" HOLE NO STEP - 42"
- P1) 48" - MH BASE - 36"
- 1) JOINT WRAP - 0.065"x6"x50' CONSEAL CS212
- 1) JOINT WRAP PRIMER - CONSEAL CS-75 (1 gal.)
- 1) 48" - MH INVERT CHANNEL - FULL HEIGHT
- 1) 48" - Conseal CS-102 1.00" (Double)
- 1) A-Lok - 0285
- 1) A-Lok - 0200

- Structure Notes:**
1. JR HOE MC-375 SELF SEALING SAN BY ICAST
  2. PER ASTM C478 SPECIFICATIONS.
  3. CONCRETE = 4,000 PSI AT 28 DAYS.
  4. REINFORCING PER ASTM A615 (GRADE 60).  
 - CONE (As .12)  
 - RISER/WALLS (As .12)  
 - FLOOR (As .31) #5 BARS AT 12" C.C.E.W.
  5. \*\*NO STEPS\*\*

Structure Total: 8442 lb

Rim: 868.13' Rim to Invert: 7.23' Slack: 0.76" Sump: 2" Step Position:

Position	Elev	Angle	Ext. (cw)	Pipe	Pipe OD	Connector	Hole	Horz Size	Up ( )	Offset
Invert 1	860.9'	0°	0"	8" PVC SDR35	8.5"	A-Lok 0285	9.75"	9.818"	1.125"	0"
Invert 2	861'	270°	136.659"	6" PVC SDR35	6.25"	A-Lok 0200	7"	7.025"	2.7"	0"
Invert 3										
Invert 4										
Invert 5										
Invert 6										
Invert 7										
Invert 8										

RIGHT-SIDE UP VIEW (int. dimensions)

UPSIDE-DOWN VIEW (int. dimensions)

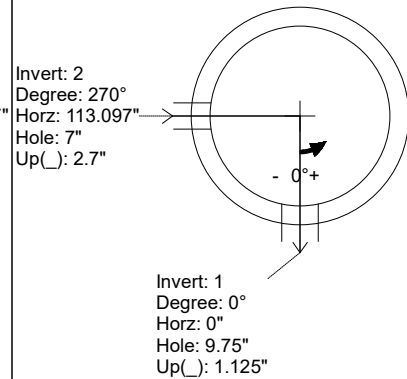
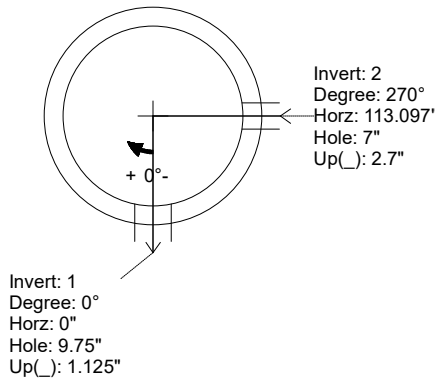
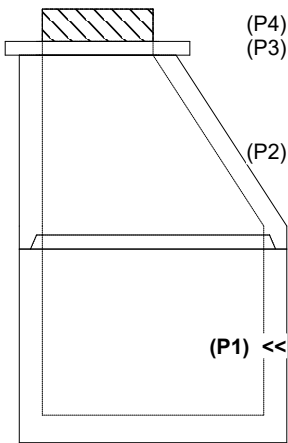

INSIDE WALL DIMENSIONS

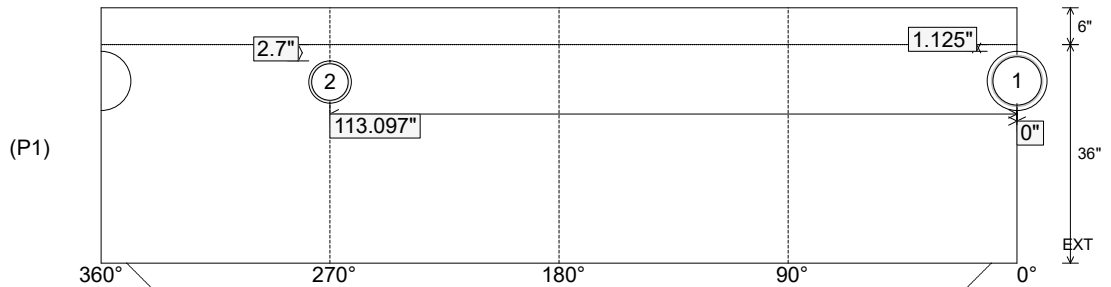

Coating (Int):  
 Coating (Ext):

Seam Up: Tongue  
 Seam Dn: n/a

Wall Thickness: 5"  
 Floor Height: 6"

Height (Int): 36"  
 Height (Ext): 42"

Weight (Net): 3797 lb  
 Volume (Net): 0.97cu.yd

Job Name: 25-1431 - Georgetown Commons  
 Job Location: Georgetown, KY  
 Contractor: Winwater Hartford KY Co.

Plant: Beaver Dam

Tech: J. Coppage

4/28/2026 8:55:49 AM

PC: A. Chambers



**Structure ID: SSMH-41**

**P1 MH048BA36**

**MH BASE**

- P4) 24" - CASTING HEIGHT - 7"
- P3) 24" - GRADE RING - 3"
- P2) 48" - ECC CONE w/ 24" HOLE NO STEP - 42"
- P1) 48" - MH BASE - 36"
- 1) JOINT WRAP - 0.065"x6"x50' CONSEAL CS212
- 1) JOINT WRAP PRIMER - CONSEAL CS-75 (1 gal.)
- 1) 48" - MH INVERT CHANNEL - FULL HEIGHT
- 1) 48" - Conseal CS-102 1.00" (Double)
- 1) A-Lok - 0285
- 1) A-Lok - 0200

- Structure Notes:**
1. JR HOE MC-375 SELF SEALING SAN BY ICAST
  2. PER ASTM C478 SPECIFICATIONS.
  3. CONCRETE = 4,000 PSI AT 28 DAYS.
  4. REINFORCING PER ASTM A615 (GRADE 60).  
 - CONE (As .12)  
 - RISER/WALLS (As .12)  
 - FLOOR (As .31) #5 BARS AT 12" C.C.E.W.
  5. \*\*NO STEPS\*\*

Structure Total: 8442 lb

**INVERT CHANNEL DRAWING  
 FULL HEIGHT INVERT**

Rim: 868.13' Rim to Invert: 7.23' Slack: 0.76" Sump: 2" Step Position:

Position	Elev	Angle	Ext. (cw)	Pipe	Pipe OD	Connector	Hole	Horz Size	Up ( )	Offset
Invert 1	860.9'	0°	0"	8" PVC SDR35	8.5"	A-Lok 0285	9.75"	9.818"	1.125"	0"
Invert 2	861'	270°	136.659"	6" PVC SDR35	6.25"	A-Lok 0200	7"	7.025"	2.7"	0"
Invert 3										
Invert 4										
Invert 5										
Invert 6										
Invert 7										
Invert 8										

RIGHT-SIDE UP VIEW (int. dimensions)

UPSIDE-DOWN VIEW (int. dimensions)

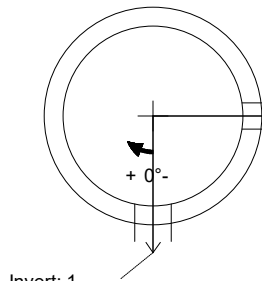
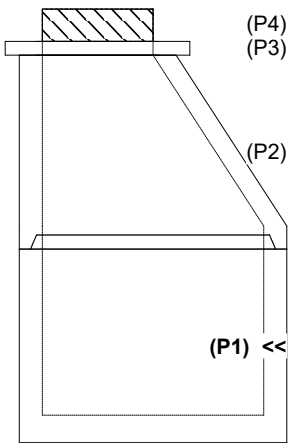

Invert: 2  
 Degree: 270°  
 Horz: 113.097"  
 Hole: 7"  
 Up( ): 2.7"

Invert: 2  
 Degree: 270°  
 Horz: 113.097"  
 Hole: 7"  
 Up( ): 2.7"

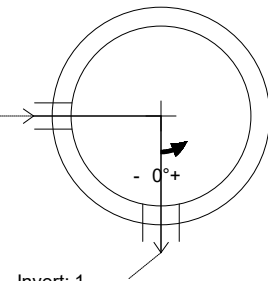

Invert: 1  
 Degree: 0°  
 Horz: 0"  
 Hole: 9.75"  
 Up( ): 1.125"

INSIDE WALL DIMENSIONS

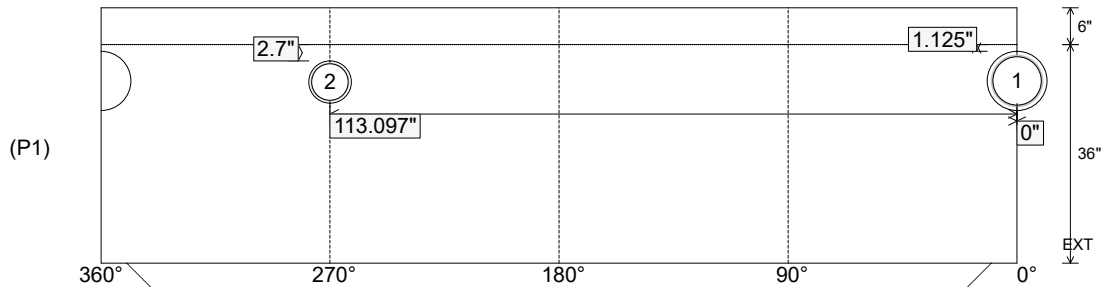

Coating (Int):  
 Coating (Ext):

Seam Up: Tongue  
 Seam Dn: n/a

Wall Thickness: 5"  
 Floor Height: 6"

Height (Int): 36"  
 Height (Ext): 42"

Weight (Net): 3797 lb  
 Volume (Net): 0.97cu.yd