

Job Name: 25-1431 - Georgetown Commons
 Job Location: Georgetown, KY
 Contractor: Winwater Hartford KY Co.

Plant: Beaver Dam

4/28/2026 8:55:50 AM

Tech: J. Coppage

PC: A. Chambers



Structure ID: SSMH-268

P1 MH048BA36

MH BASE

- P4) 24" - CASTING HEIGHT - 7"
- P3) 24" - GRADE RING - 6"
- P2) 48" - ECC CONE w/ 24" HOLE NO STEP - 42"
- P1) 48" - MH BASE - 36"
- 1) JOINT WRAP - 0.065"x6"x50' CONSEAL CS212
- 1) JOINT WRAP PRIMER - CONSEAL CS-75 (1 gal.)
- 1) 48" - MH INVERT CHANNEL - FULL HEIGHT
- 1) 48" - Conseal CS-102 1.00" (Double)
- 3) A-Lok - 0285

- Structure Notes:**
1. JR HOE MC-375 SELF SEALING SAN BY ICAST
 2. PER ASTM C478 SPECIFICATIONS.
 3. CONCRETE = 4,000 PSI AT 28 DAYS.
 4. REINFORCING PER ASTM A615 (GRADE 60).
 - CONE (As .12)
 - RISER/WALLS (As .12)
 - FLOOR (As .31) #5 BARS AT 12" C.C.E.W.
 5. **NO STEPS**

Structure Total: 8599 lb

Rim: 876.66' Rim to Invert: 7.56' Slack: 1.72" Sump: 2" Step Position:

Position	Elev	Angle	Ext. (cw)	Pipe	Pipe OD	Connector	Hole	Horz Size	Up ()	Offset
Invert 1	869.1'	0°	0"	8" PVC SDR35	8.5"	A-Lok 0285	9.75"	9.818"	1.125"	0"
Invert 2	869.2'	90°	45.553"	8" PVC SDR35	8.5"	A-Lok 0285	9.75"	9.818"	2.325"	0"
Invert 3	869.2'	180°	91.106"	8" PVC SDR35	8.5"	A-Lok 0285	9.75"	9.818"	2.325"	0"
Invert 4										
Invert 5										
Invert 6										
Invert 7										
Invert 8										

RIGHT-SIDE UP VIEW (int. dimensions)

UPSIDE-DOWN VIEW (int. dimensions)

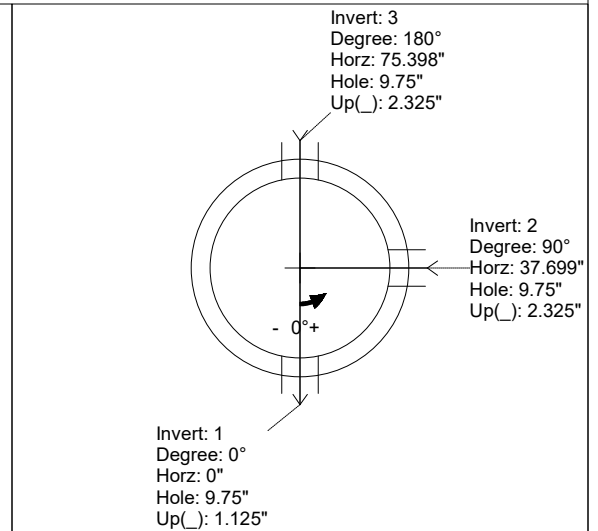
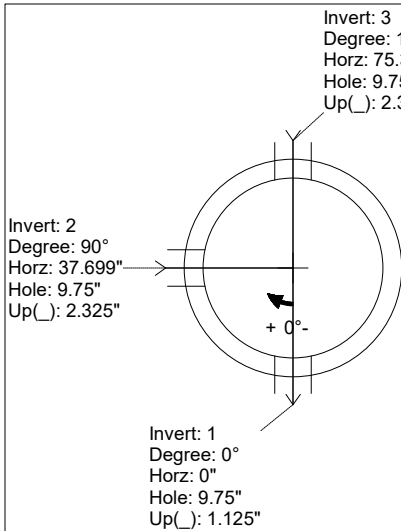
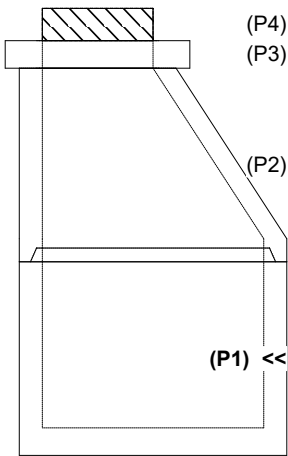

INSIDE WALL DIMENSIONS

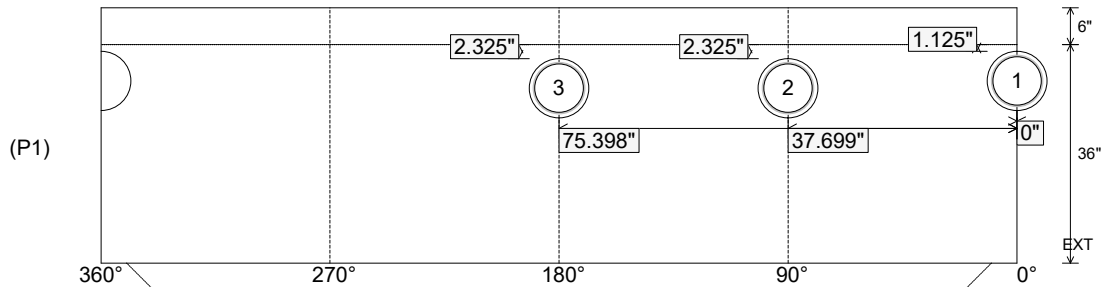

Coating (Int):
Coating (Ext):

Seam Up: Tongue
Seam Dn: n/a

Wall Thickness: 5"
Floor Height: 6"

Height (Int): 36"
Height (Ext): 42"

Weight (Net): 3751 lb
Volume (Net): 0.96cu.yd

Job Name: 25-1431 - Georgetown Commons
 Job Location: Georgetown, KY
 Contractor: Winwater Hartford KY Co.

Plant: Beaver Dam

4/28/2026 8:55:50 AM

Tech: J. Coppage

PC: A. Chambers



Structure ID: SSMH-268

P1 MH048BA36

MH BASE

- P4) 24" - CASTING HEIGHT - 7"
- P3) 24" - GRADE RING - 6"
- P2) 48" - ECC CONE w/ 24" HOLE NO STEP - 42"
- P1) 48" - MH BASE - 36"
- 1) JOINT WRAP - 0.065"x6"x50' CONSEAL CS212
- 1) JOINT WRAP PRIMER - CONSEAL CS-75 (1 gal.)
- 1) 48" - MH INVERT CHANNEL - FULL HEIGHT
- 1) 48" - Conseal CS-102 1.00" (Double)
- 3) A-Lok - 0285

- Structure Notes:
1. JR HOE MC-375 SELF SEALING SAN BY ICAST
 2. PER ASTM C478 SPECIFICATIONS.
 3. CONCRETE = 4,000 PSI AT 28 DAYS.
 4. REINFORCING PER ASTM A615 (GRADE 60).
 - CONE (As .12)
 - RISER/WALLS (As .12)
 - FLOOR (As .31) #5 BARS AT 12" C.C.E.W.
 5. **NO STEPS**

Structure Total: 8599 lb

**INVERT CHANNEL DRAWING
 FULL HEIGHT INVERT**

Rim: 876.66' Rim to Invert: 7.56' Slack: 1.72" Sump: 2" Step Position:

Position	Elev	Angle	Ext. (cw)	Pipe	Pipe OD	Connector	Hole	Horz Size	Up ()	Offset
Invert 1	869.1'	0°	0"	8" PVC SDR35	8.5"	A-Lok 0285	9.75"	9.818"	1.125"	0"
Invert 2	869.2'	90°	45.553"	8" PVC SDR35	8.5"	A-Lok 0285	9.75"	9.818"	2.325"	0"
Invert 3	869.2'	180°	91.106"	8" PVC SDR35	8.5"	A-Lok 0285	9.75"	9.818"	2.325"	0"
Invert 4										
Invert 5										
Invert 6										
Invert 7										
Invert 8										

RIGHT-SIDE UP VIEW (int. dimensions)

UPSIDE-DOWN VIEW (int. dimensions)

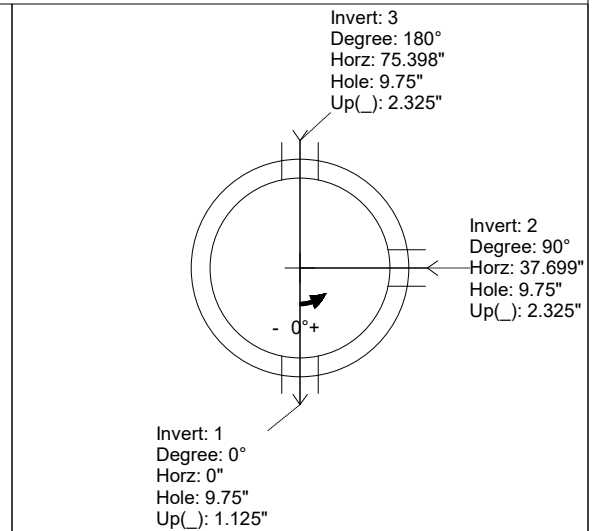
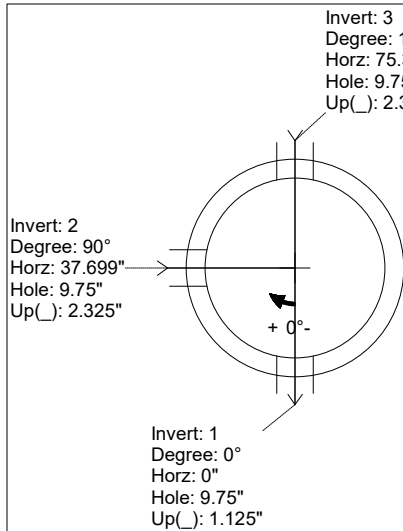
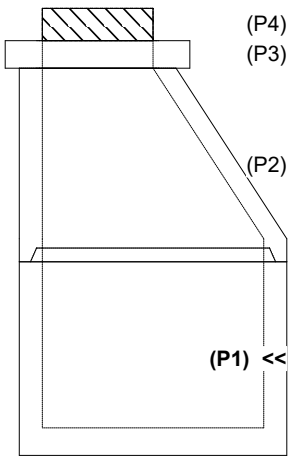

INSIDE WALL DIMENSIONS

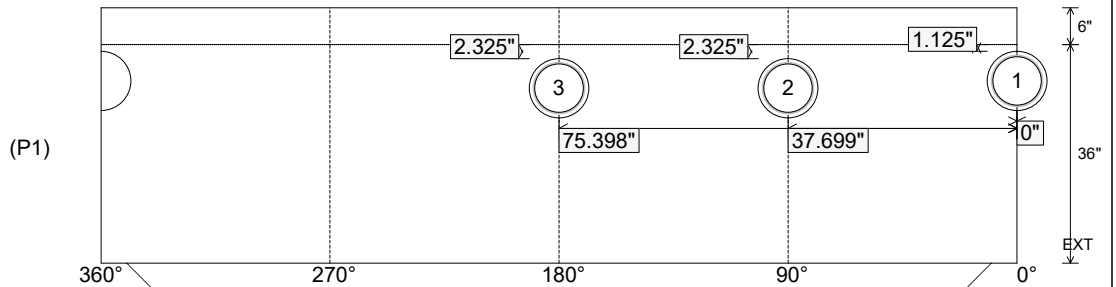

Coating (Int):
 Coating (Ext):

Seam Up: Tongue
 Seam Dn: n/a

Wall Thickness: 5"
 Floor Height: 6"

Height (Int): 36"
 Height (Ext): 42"

Weight (Net): 3751 lb
 Volume (Net): 0.96cu.yd