

Job Name: 25-1431 - Georgetown Commons
 Job Location: Georgetown, KY
 Contractor: Winwater Hartford KY Co.

Plant: Beaver Dam

4/28/2026 8:55:50 AM

Tech: J. Coppage

PC: A. Chambers



Structure ID: SSMH-229

P1 MH048BA30

MH BASE

- P4) 24" - CASTING HEIGHT - 7"
- P3) 24" - GRADE RING - 3"
- P2) 48" - ECC CONE w/ 24" HOLE NO STEP - 36"
- P1) 48" - MH BASE - 30"
- 1) JOINT WRAP - 0.065"x6"x50' CONSEAL CS212
- 1) JOINT WRAP PRIMER - CONSEAL CS-75 (1 gal.)
- 1) 48" - MH INVERT CHANNEL - FULL HEIGHT
- 1) 48" - Conseal CS-102 1.00" (Double)
- 2) A-Lok - 0285

- Structure Notes:**
1. JR HOE MC-375 SELF SEALING SAN BY ICAST
 2. PER ASTM C478 SPECIFICATIONS.
 3. CONCRETE = 4,000 PSI AT 28 DAYS.
 4. REINFORCING PER ASTM A615 (GRADE 60).
 - CONE (As .12)
 - RISER/WALLS (As .12)
 - FLOOR (As .31) #5 BARS AT 12" C.C.E.W.
 5. **NO STEPS**

Structure Total: 8007 lb

Rim: 881.11' Rim to Invert: 6.21' Slack: 0.52" Sump: 2" Step Position:

Position	Elev	Angle	Ext. (cw)	Pipe	Pipe OD	Connector	Hole	Horz Size	Up ()	Offset
Invert 1	874.9'	0°	0"	8" PVC SDR35	8.5"	A-Lok 0285	9.75"	9.818"	1.125"	0"
Invert 2	875'	180°	91.106"	8" PVC SDR35	8.5"	A-Lok 0285	9.75"	9.818"	2.325"	0"
Invert 3										
Invert 4										
Invert 5										
Invert 6										
Invert 7										
Invert 8										

RIGHT-SIDE UP VIEW (int. dimensions)

UPSIDE-DOWN VIEW (int. dimensions)

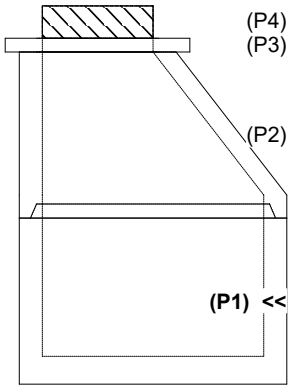
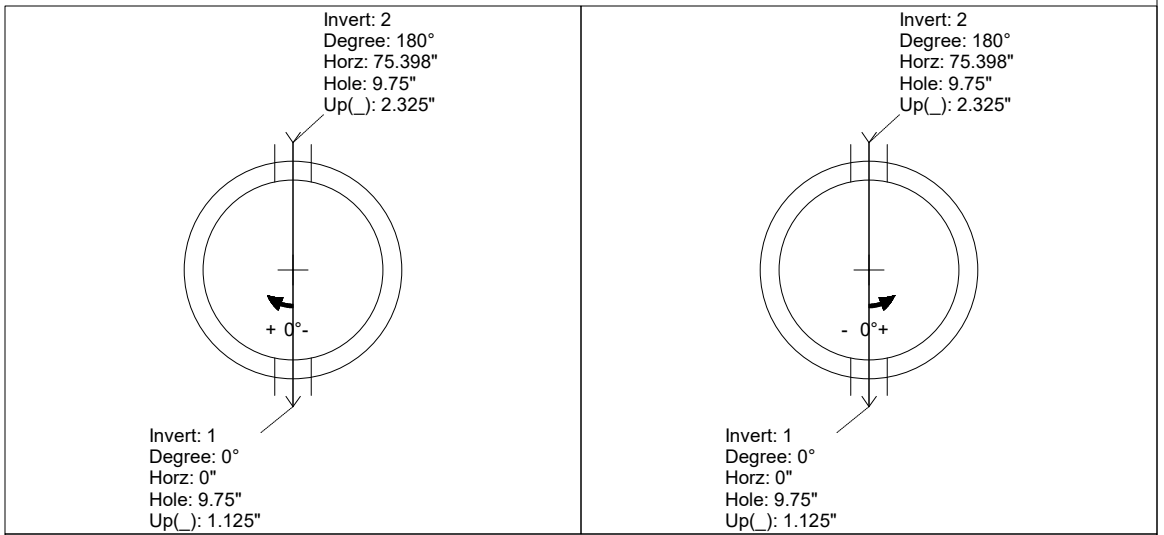

INSIDE WALL DIMENSIONS

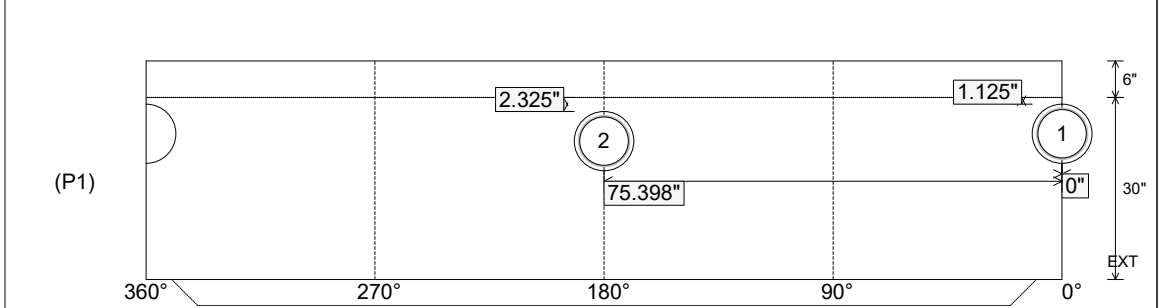

Coating (Int):
 Coating (Ext):

Seam Up: Tongue
 Seam Dn: n/a

Wall Thickness: 5"
 Floor Height: 6"

Height (Int): 30"
 Height (Ext): 36"

Weight (Net): 3363 lb
 Volume (Net): 0.86cu.yd

Job Name: 25-1431 - Georgetown Commons
 Job Location: Georgetown, KY
 Contractor: Winwater Hartford KY Co.

Plant: Beaver Dam

4/28/2026 8:55:50 AM

Tech: J. Coppage

PC: A. Chambers



Structure ID: SSMH-229

P1 MH048BA30

MH BASE

- P4) 24" - CASTING HEIGHT - 7"
- P3) 24" - GRADE RING - 3"
- P2) 48" - ECC CONE w/ 24" HOLE NO STEP - 36"
- P1) 48" - MH BASE - 30"
- 1) JOINT WRAP - 0.065"x6"x50' CONSEAL CS212
- 1) JOINT WRAP PRIMER - CONSEAL CS-75 (1 gal.)
- 1) 48" - MH INVERT CHANNEL - FULL HEIGHT
- 1) 48" - Conseal CS-102 1.00" (Double)
- 2) A-Lok - 0285

- Structure Notes:**
1. JR HOE MC-375 SELF SEALING SAN BY ICAST
 2. PER ASTM C478 SPECIFICATIONS.
 3. CONCRETE = 4,000 PSI AT 28 DAYS.
 4. REINFORCING PER ASTM A615 (GRADE 60).
 - CONE (As .12)
 - RISER/WALLS (As .12)
 - FLOOR (As .31) #5 BARS AT 12" C.C.E.W.
 5. **NO STEPS**

Structure Total: 8007 lb

**INVERT CHANNEL DRAWING
 FULL HEIGHT INVERT**

Rim: 881.11' Rim to Invert: 6.21' Slack: 0.52" Sump: 2" Step Position:

Position	Elev	Angle	Ext. (cw)	Pipe	Pipe OD	Connector	Hole	Horz Size	Up ()	Offset
Invert 1	874.9'	0°	0"	8" PVC SDR35	8.5"	A-Lok 0285	9.75"	9.818"	1.125"	0"
Invert 2	875'	180°	91.106"	8" PVC SDR35	8.5"	A-Lok 0285	9.75"	9.818"	2.325"	0"
Invert 3										
Invert 4										
Invert 5										
Invert 6										
Invert 7										
Invert 8										

RIGHT-SIDE UP VIEW (int. dimensions)

UPSIDE-DOWN VIEW (int. dimensions)

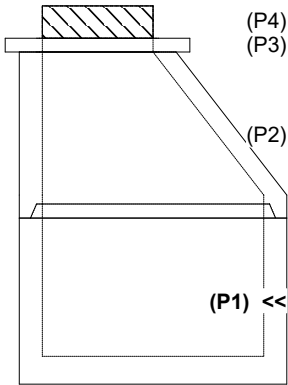
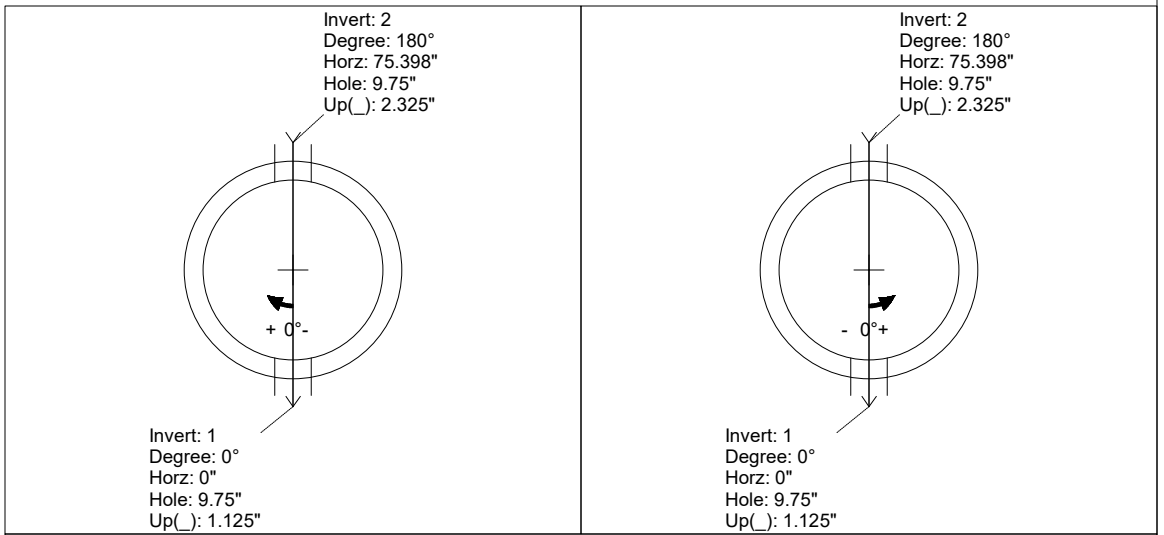

INSIDE WALL DIMENSIONS

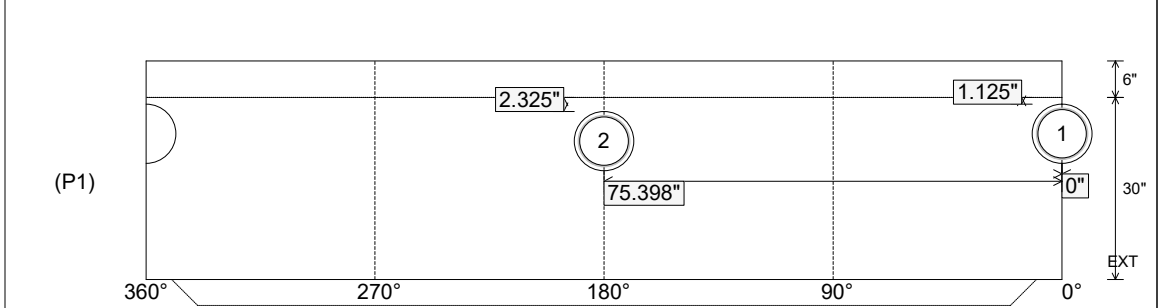

Coating (Int): Coating (Ext):	Seam Up: Tongue Seam Dn: n/a	Wall Thickness: 5" Floor Height: 6"	Height (Int): 30" Height (Ext): 36"	Weight (Net): 3363 lb Volume (Net): 0.86cu.yd
----------------------------------	---------------------------------	--	--	--