

Job Name: 25-1431 - Georgetown Commons  
 Job Location: Georgetown, KY  
 Contractor: Winwater Hartford KY Co.

Plant: Beaver Dam

4/23/2026 11:30:35 AM

Tech: J. Copping

PC: A. Chambers



**Structure ID: SCI 43**

**P2 MH060LD13-24X30RECT**

**MH FLAT TOP w/24"x30" Hole**

- P3) 24" x 30" - CASTING HEIGHT - 6"
- P2) 60" - MH FLAT TOP w/24"x30" Hole - 13"
- P1) 60" - MH BASE Custom Ht - 69"
- 1) CASTING - HOE 360 Set (F/G/H)
- 1) 60" - Conseal CS-102 1.00"
- 1) 24" x 30" - Conseal CS-102 1.00"
- 1) Hole - 44
- 2) Hole - 30
- 1) Hole - 24
- 6) MH Step ML-10-TDS-NCR - 10"

- Structure Notes:**
1. JR HOE HOE-360 PROVIDED BY ICAST.
  2. PER ASTM C478 SPECIFICATIONS.
  3. CONCRETE = 4,000 PSI AT 28 DAYS.
  4. REINFORCING PER ASTM A615 (GRADE 60).
    - TOP SLAB (As .62) #5 BARS AT 6" C.C.E.W..
    - RISER/WALLS (As .18)
    - FLOOR (As .37) #5 BARS AT 10" C.C.E.W.

Structure Total: 11152 lb

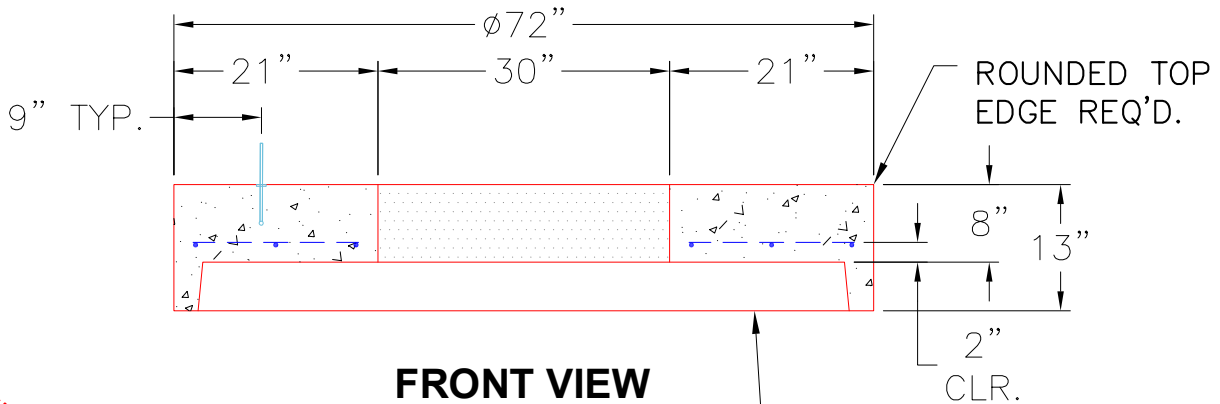
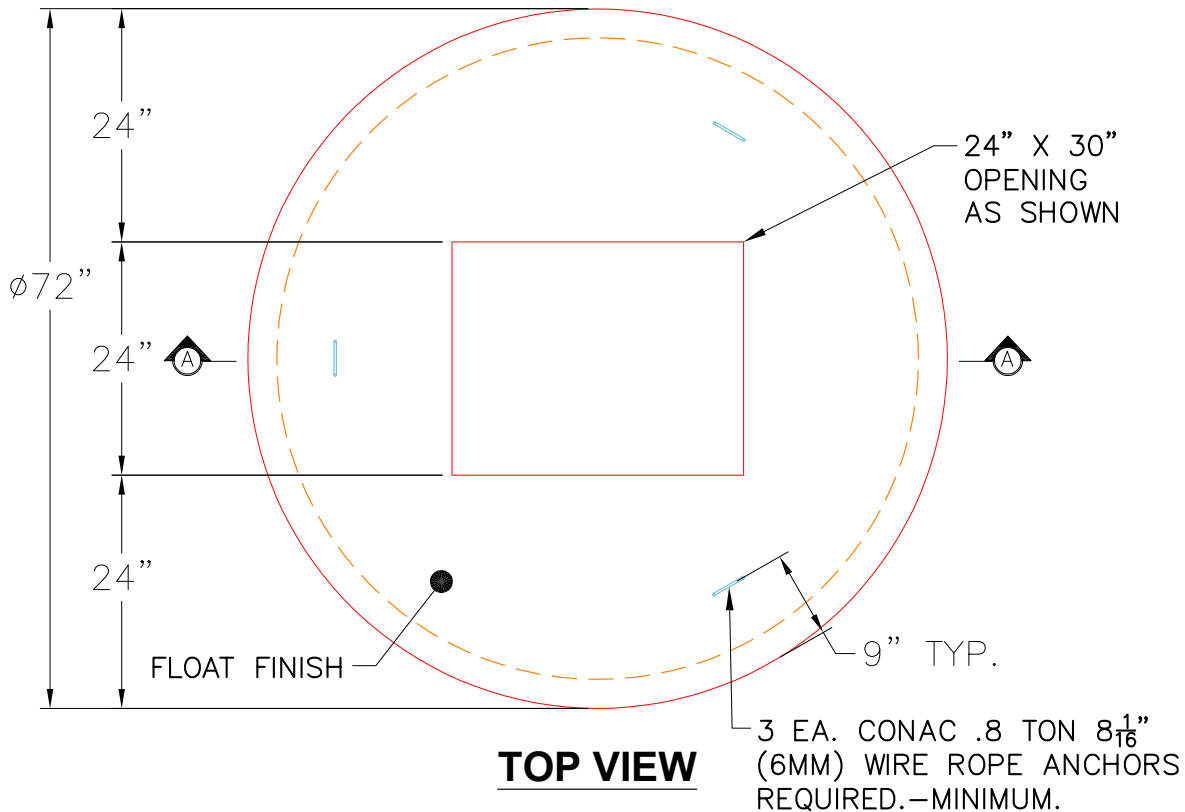

**NOTES:**

1. MANUFACTURED TO ASTM C-478 (LATEST REVISION).
2. CONCRETE: 5,000 PSI AT 28 DAYS.
3. REINFORCING: #4 BAR @ 9" O.C. E.W. (GRADE 60).

STANDARD SINGLE OFFSET GROOVE JOINT REQUIRED.

Coating (Int): Coating (Ext):	Seam Up: Flat Seam Dn: Groove	Wall Thickness: 6"	Height (Ext): 13"	Weight (Net): 2668 lb Volume (Net): 0.68cu.yd
----------------------------------	----------------------------------	--------------------	-------------------	--