

Job Name: 25-1431 - Georgetown Commons  
 Job Location: Georgetown, KY  
 Contractor: Winwater Hartford KY Co.

Plant: Beaver Dam

Tech: J. Coppage

4/23/2026 11:19:51 AM

PC: A. Chambers



**Structure ID: SCI 30**

**P1 MH072BA84**

**MH BASE**

- P4) 24" x 30" - CASTING HEIGHT - 6"
- P3) 24" x 30" - GRADE RING - 3"
- P2) 72" - MH FLAT TOP w/24"x30" Hole - 15"
- P1) 72" - MH BASE - 84"
- 1) CASTING - HOE 360 Set (F/G/H)
- 1) 72" - Conseal CS-102 1.00"
- 2) 24" x 30" - Conseal CS-102 1.00"
- 2) Hole - 50
- 1) Hole - 12
- 7) MH Step ML-10-TDS-NCR - 10"

- Structure Notes:**
1. JR HOE HOE-360 PROVIDED BY ICAST.
  2. PER ASTM C478 SPECIFICATIONS.
  3. CONCRETE = 4,000 PSI AT 28 DAYS.
  4. REINFORCING PER ASTM A615 (GRADE 60).  
 - TOP SLAB (As .62) #5 BARS AT 6" C.C.E.W..  
 - RISER/WALLS (As .18)  
 - FLOOR (As .37) #5 BARS AT 10" C.C.E.W.

Structure Total: 18778 lb

Rim: 868.5' Rim to Invert: 9' Slack: 3.15" Sump: 3.15" Step Position: 285.5"

| Position | Elev   | Angle | Ext. (cw) | Pipe     | Pipe OD | Connector | Hole | Horz Size | Up ( ) | Offset |
|----------|--------|-------|-----------|----------|---------|-----------|------|-----------|--------|--------|
| Invert 1 | 859.5' | 0°    | 0"        | 42" HDPE | 47.7"   | Hole 50   | 50"  | 55.271"   | 0"     | 0"     |
| Invert 2 | 859.9' | 120°  | 90.059"   | 42" HDPE | 47.7"   | Hole 50   | 50"  | 55.271"   | 4.8"   | 0"     |
| Invert 3 | 859.9' | 211°  | 158.354"  | 8" HDPE  | 9.1"    | Hole 12   | 12"  | 12.056"   | 7.4"   | 0"     |
| Invert 4 |        |       |           |          |         |           |      |           |        |        |
| Invert 5 |        |       |           |          |         |           |      |           |        |        |
| Invert 6 |        |       |           |          |         |           |      |           |        |        |
| Invert 7 |        |       |           |          |         |           |      |           |        |        |
| Invert 8 |        |       |           |          |         |           |      |           |        |        |

RIGHT-SIDE UP VIEW (int. dimensions)

UPSIDE-DOWN VIEW (int. dimensions)

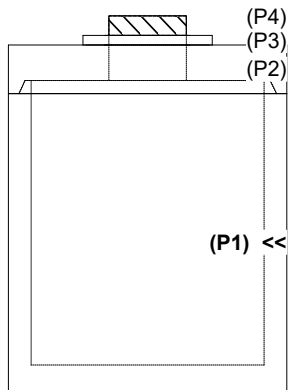
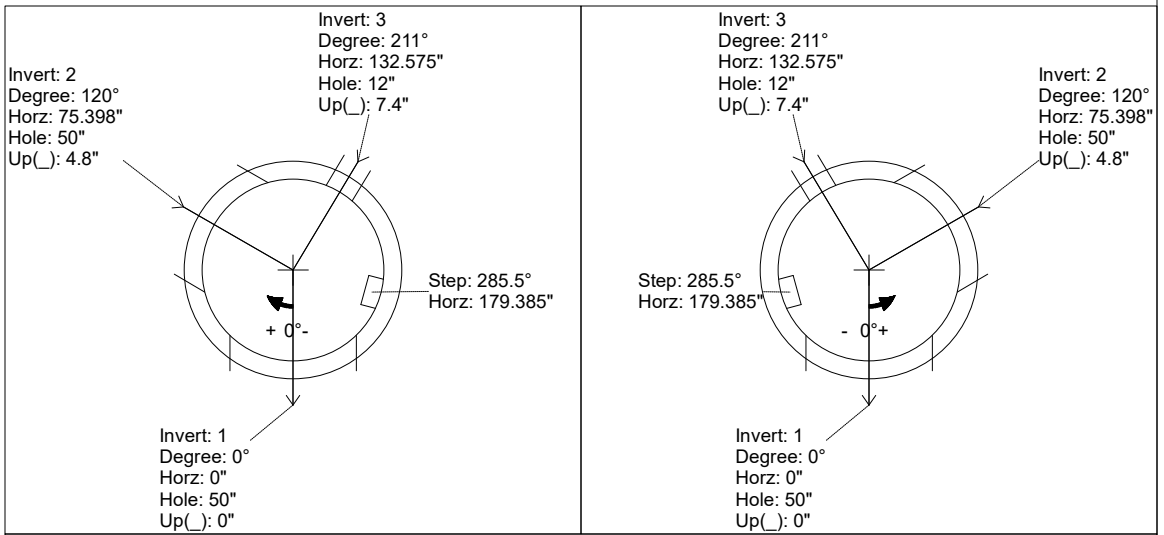

INSIDE WALL DIMENSIONS

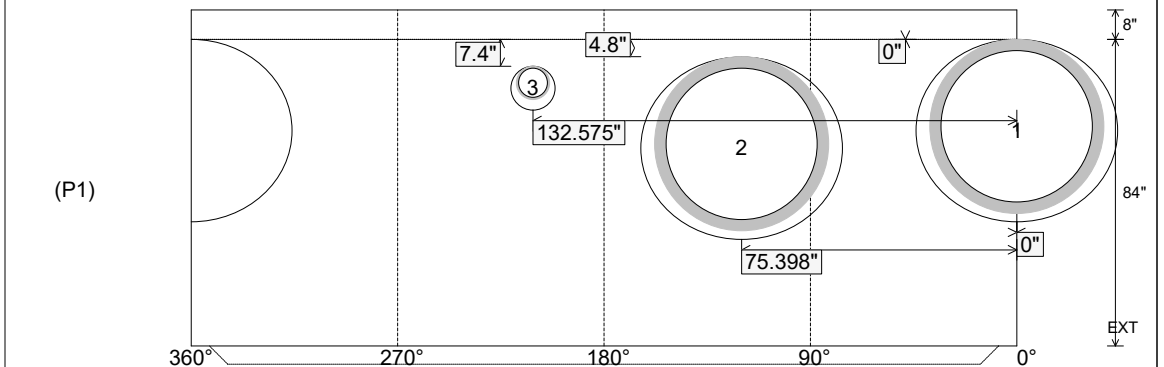

Coating (Int):  
 Coating (Ext):

Seam Up: Tongue  
 Seam Dn: n/a

Wall Thickness: 7"  
 Floor Height: 8"

Height (Int): 84"  
 Height (Ext): 92"

Weight (Net): 13573 lb  
 Volume (Net): 3.47cu.yd