

Job Name: 25-1431 - Georgetown Commons  
 Job Location: Georgetown, KY  
 Contractor: Winwater Hartford KY Co.

Plant: Beaver Dam  
 4/23/2026 11:30:30 AM

Tech: J. Copping  
 PC: A. Chambers



**Structure ID: SCI 24**

**P2 MH048LD12-24X30RECT**

**MH FLAT TOP w/24"x30" Hole**

- P4) 24" x 30" - CASTING HEIGHT - 6"
- P3) 24" x 30" - GRADE RING - 4"
- P2) 48" - MH FLAT TOP w/24"x30" Hole - 12"
- P1) 48" - MH BASE - 42"
- 1) CASTING - HOE 360 Set (F/G/H)
- 1) 48" - Conseal CS-102 1.00"
- 2) 24" x 30" - Conseal CS-102 1.00"
- 1) Hole - 26
- 1) Hole - 22
- 3) MH Step ML-10-TDS-NCR - 10"

- Structure Notes:**
1. JR HOE HOE-360 PROVIDED BY ICAST.
  2. PER ASTM C478 SPECIFICATIONS.
  3. CONCRETE = 4,000 PSI AT 28 DAYS.
  4. REINFORCING PER ASTM A615 (GRADE 60).
    - TOP SLAB (As .62) #5 BARS AT 6" C.C.E.W..
    - RISER/WALLS (As .12)
    - FLOOR (As .31) #5 BARS AT 12" C.C.E.W.

Structure Total: 6430 lb

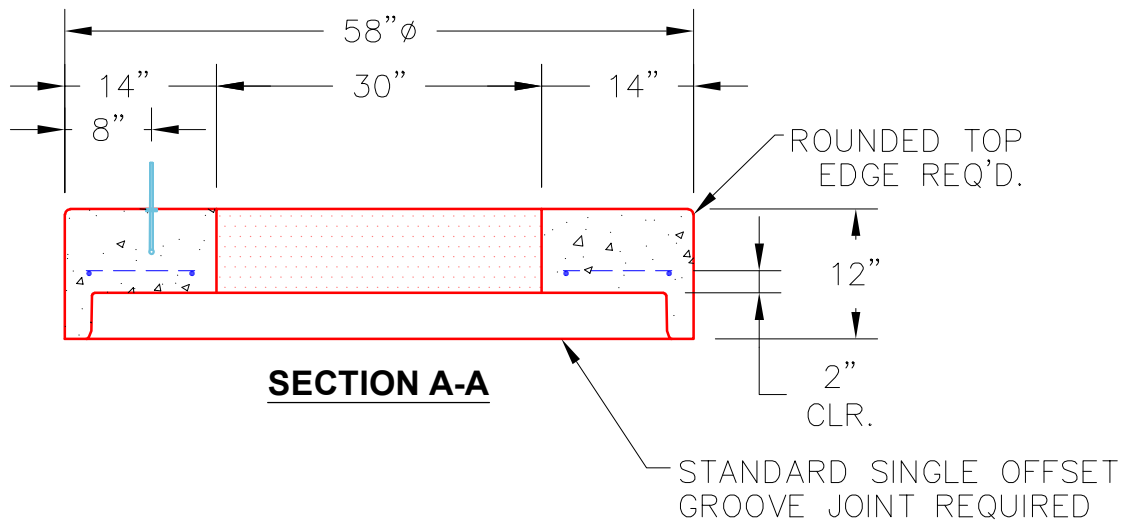
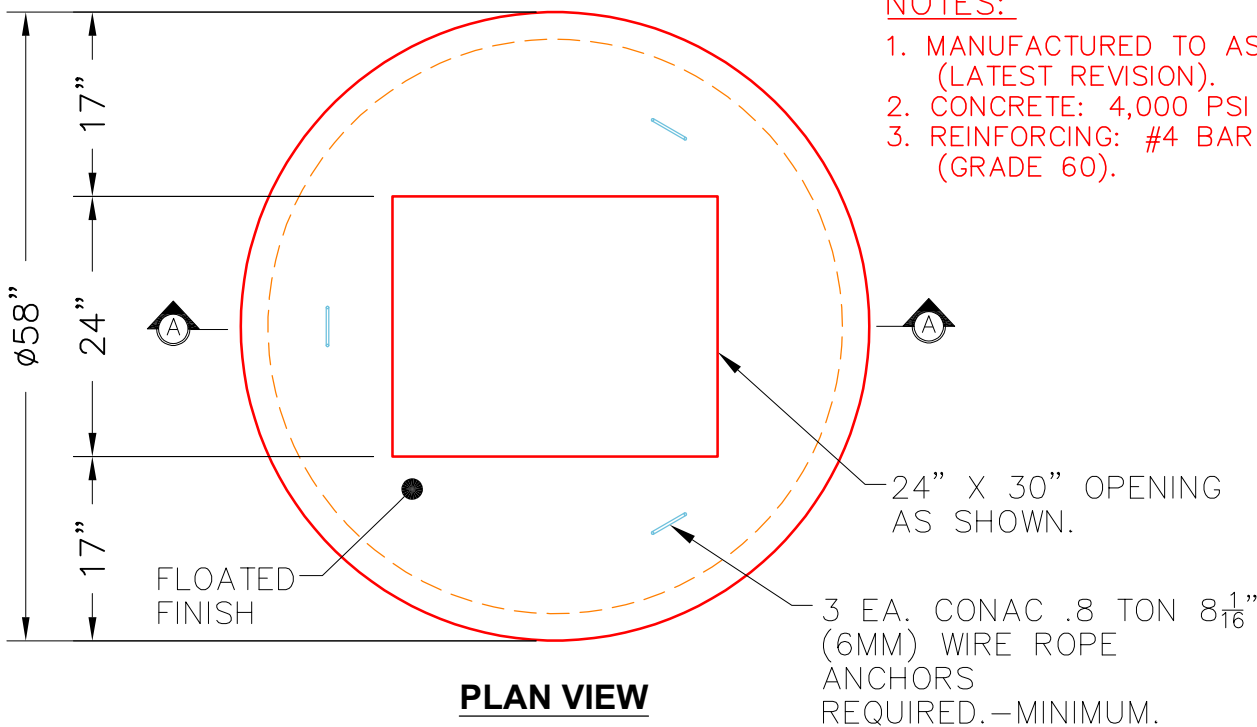

Coating (Int):  
 Coating (Ext):

Seam Up: Flat  
 Seam Dn: Groove

Wall Thickness: 5"

Height (Ext): 12"

Weight (Net): 1935 lb  
 Volume (Net): 0.49cu.yd