

Job Name: 25-1431 - Georgetown Commons
 Job Location: Georgetown, KY
 Contractor: Winwater Hartford KY Co.

Plant: Beaver Dam

4/23/2026 11:20:14 AM

Tech: J. Coppage

PC: A. Chambers



Structure ID: SCI 112

P1 MH060BA60

MH BASE

- P4) 24" x 30" - CASTING HEIGHT - 6"
- P3) 60" - MH FLAT TOP w/24"x30" Hole - 13"
- P2) 60" - MH RISER - 30"
- P1) 60" - MH BASE - 60"
- 1) CASTING - HOE 360 Set (F/G/H)
- 2) 60" - Conseal CS-102 1.00"
- 1) 24" x 30" - Conseal CS-102 1.00"
- 2) Hole - 46
- 8) MH Step ML-10-TDS-NCR - 10"

- Structure Notes:**
1. JR HOE HOE-360 PROVIDED BY ICAST.
 2. PER ASTM C478 SPECIFICATIONS.
 3. CONCRETE = 4,000 PSI AT 28 DAYS.
 4. REINFORCING PER ASTM A615 (GRADE 60).
 - TOP SLAB (As .62) #5 BARS AT 6" C.C.E.W..
 - RISER/WALLS (As .18)
 - FLOOR (As .37) #5 BARS AT 10" C.C.E.W.

Structure Total: 13297 lb

Rim: 870.5' Rim to Invert: 9' Slack: 1.85" Sump: 2.85" Step Position: 268"

Position	Elev	Angle	Ext. (cw)	Pipe	Pipe OD	Connector	Hole	Horz Size	Up (↓)	Offset
Invert 1	861.5'	0°	0"	36" HDPE	41.7"	Hole 46	46"	52.418"	0"	0"
Invert 2	861.5'	176°	110.584"	36" HDPE	41.7"	Hole 46	46"	52.418"	0"	0"
Invert 3										
Invert 4										
Invert 5										
Invert 6										
Invert 7										
Invert 8										

RIGHT-SIDE UP VIEW (int. dimensions)

UPSIDE-DOWN VIEW (int. dimensions)

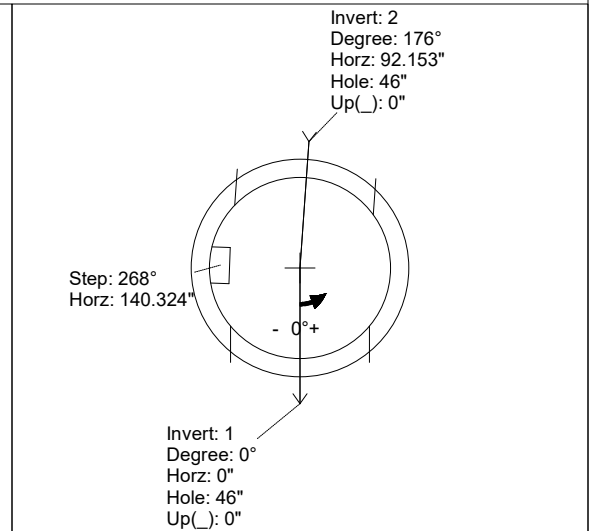
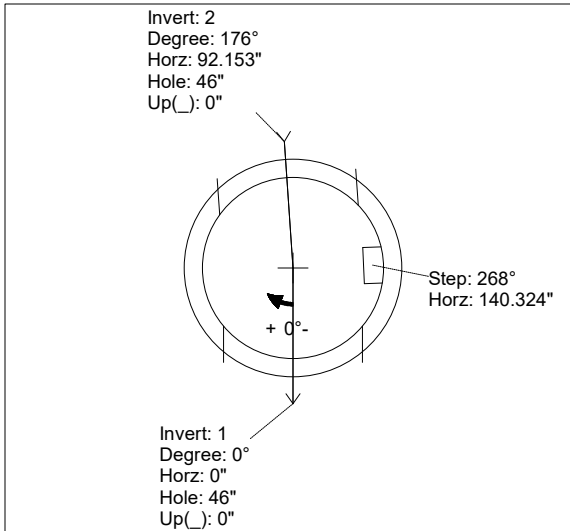
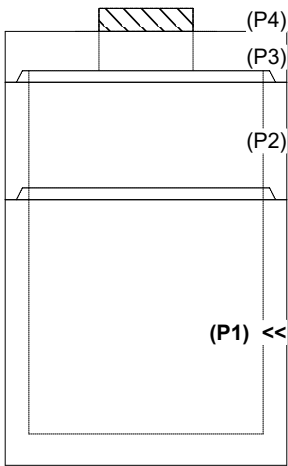

INSIDE WALL DIMENSIONS

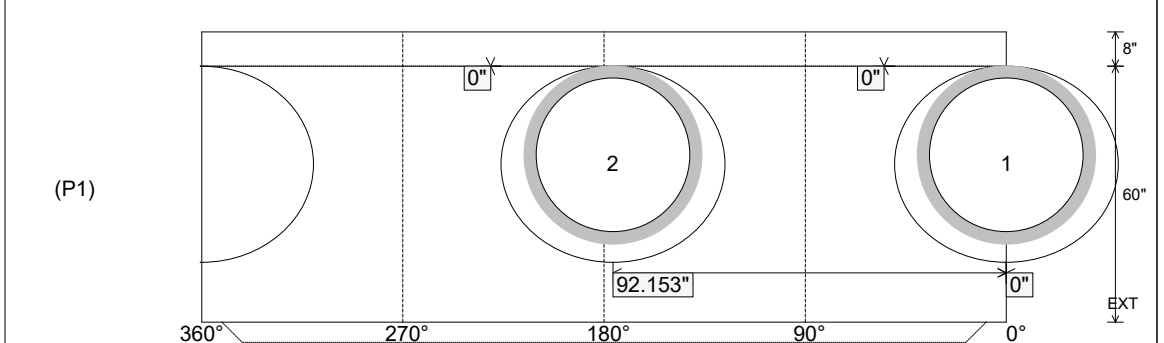

Coating (Int): Coating (Ext):	Seam Up: Tongue Seam Dn: n/a	Wall Thickness: 6" Floor Height: 8"	Height (Int): 60" Height (Ext): 68"	Weight (Net): 7136 lb Volume (Net): 1.82cu.yd
----------------------------------	---------------------------------	--	--	--