

Job Name: 25-1431 - Georgetown Commons
 Job Location: Georgetown, KY
 Contractor: Winwater Hartford KY Co.

Plant: Beaver Dam

Tech: J. Coppage

4/9/2026 9:59:59 AM

PC: A. Chambers



Structure ID: MH 329

P1 MH096BA96

MH BASE

- P4) 24" - CASTING HEIGHT - 7"
- P3) 96" - MH FLAT TOP w/ 24" ECC Hole - 17"
- P2) 96" - MH RISER - 36"
- P1) 96" - MH BASE - 96"
- 1) CASTING - HOE MC-420 F/C Storm LOU-MSD
- 2) 96" - Conseal CS-102 1.00"
- 1) Hole - 75
- 1) Hole - 30
- 1) Hole - 40
- 1) Hole - 68
- 11) MH Step ML-10-TDS-NCR - 10"

- Structure Notes:**
1. JR HOE MC-420 PROVIDED BY ICAST.
 2. PER ASTM C478 SPECIFICATIONS.
 3. CONCRETE = 4,000 PSI AT 28 DAYS.
 4. REINFORCING PER ASTM A615 (GRADE 60).
 - TOP SLAB (As .62) #5 BARS AT 6" C.C.E.W..
 - RISER/WALLS (As .18)
 - FLOOR (As .37) #5 BARS AT 10" C.C.E.W.

0 lb
 10472 lb
 8798 lb
 22694 lb
 340 lb
 0 lb
 0 lb
 0 lb
 0 lb
 0 lb
 0 lb
 0 lb

Structure Total: 42303 lb

Rim: 869.5' Rim to Invert: 12.7' Slack: 2.4" Sump: 6" Step Position: 291°

Position	Elev	Angle	Ext. (cw)	Pipe	Pipe OD	Connector	Hole	Horz Size	Up ()	Offset
Invert 1	856.8'	0°	0"	60" RCP B WALL	72"	Hole 75	75"	86.08"	0"	0"
Invert 2	860.1'	110°	109.432"	24" HDPE	27.8"	Hole 30	30"	30.511"	43.7"	0"
Invert 3	861.95'	166°	165.143"	30" HDPE	35.1"	Hole 40	40"	41.258"	65.25"	0"
Invert 4	856.8'	222°	220.854"	54" RCP B WALL	65"	Hole 68	68"	75.565"	0.5"	0"
Invert 5										
Invert 6										
Invert 7										
Invert 8										

RIGHT-SIDE UP VIEW (int. dimensions)

UPSIDE-DOWN VIEW (int. dimensions)

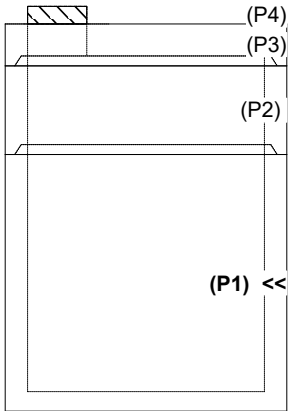
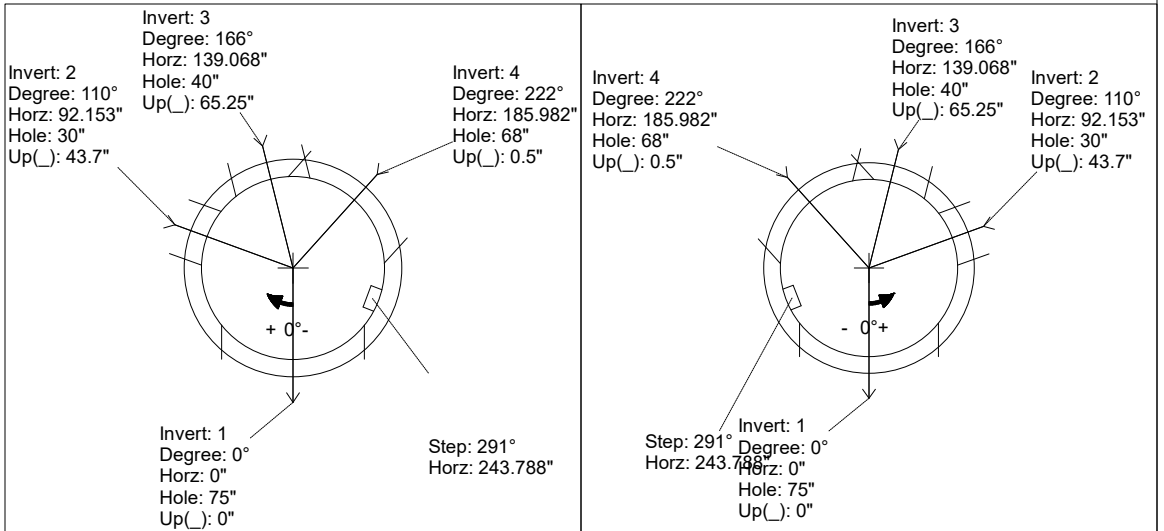

INSIDE WALL DIMENSIONS

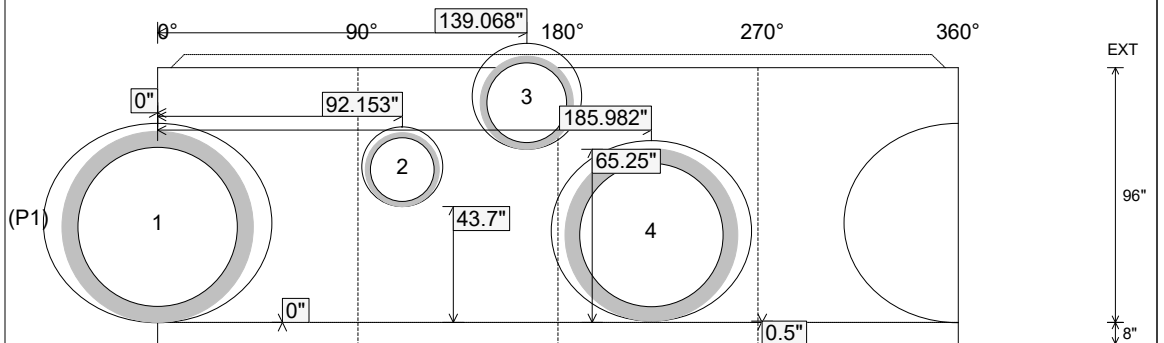

Coating (Int):
 Coating (Ext):

Seam Up: Tongue
 Seam Dn: n/a

Wall Thickness: 9"
 Floor Height: 8"

Height (Int): 96"
 Height (Ext): 104"

Weight (Net): 22694 lb
 Volume (Net): 5.8cu.yd