

Job Name: 25-1431 - Georgetown Commons
 Job Location: Georgetown, KY
 Contractor: Winwater Hartford KY Co.

Plant: Beaver Dam

4/23/2026 11:20:10 AM

Tech: J. Coppage

PC: A. Chambers



Structure ID: DCI 106

P1 MH072BAVF

MH BASE Custom Ht

- P3) 24" x 36" - CASTING HEIGHT - 6"
- P2) 72" - MH FLAT TOP w/24"x36" Hole - 15"
- P1) 72" - MH BASE Custom Ht - 64"
- 1) CASTING - HOE 470 SET (F/G/H)
- 1) 72" - Conseal CS-102 1.00"
- 1) 24" x 36" - Conseal CS-102 1.00"
- 1) Hole - 46
- 1) Hole - 40
- 5) MH Step ML-10-TDS-NCR - 10"

- Structure Notes:**
1. JR HOE HOE-470 PROVIDED BY ICAST.
 2. PER ASTM C478 SPECIFICATIONS.
 3. CONCRETE = 4,000 PSI AT 28 DAYS.
 4. REINFORCING PER ASTM A615 (GRADE 60).
 - TOP SLAB (As .62) #5 BARS AT 6" C.C.E.W..
 - RISER/WALLS (As .18)
 - FLOOR (As .37) #5 BARS AT 10" C.C.E.W.

Structure Total: 16333 lb

Rim: 870.5' Rim to Invert: 7' Slack: 1.85" Sump: 2.85" Step Position: 225°

Position	Elev	Angle	Ext. (cw)	Pipe	Pipe OD	Connector	Hole	Horz Size	Up (↓)	Offset
Invert 1	863.5'	0°	0"	36" HDPE	41.7"	Hole 46	46"	49.9"	0"	0"
Invert 2	863.5'	90°	67.544"	30" HDPE	35.1"	Hole 40	40"	42.41"	0.3"	0"
Invert 3										
Invert 4										
Invert 5										
Invert 6										
Invert 7										
Invert 8										

RIGHT-SIDE UP VIEW (int. dimensions)

UPSIDE-DOWN VIEW (int. dimensions)

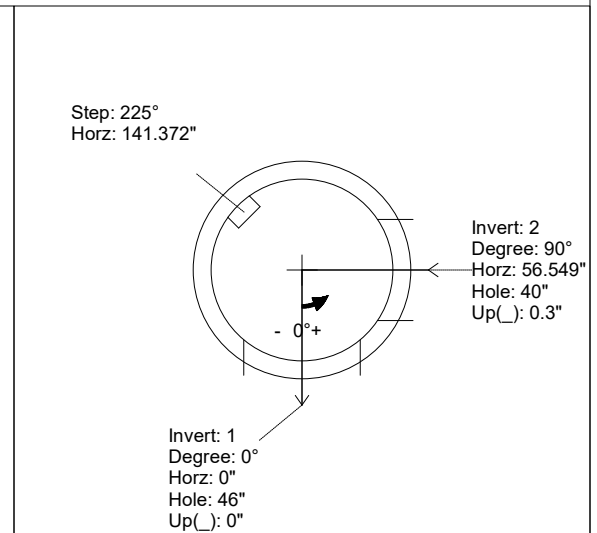
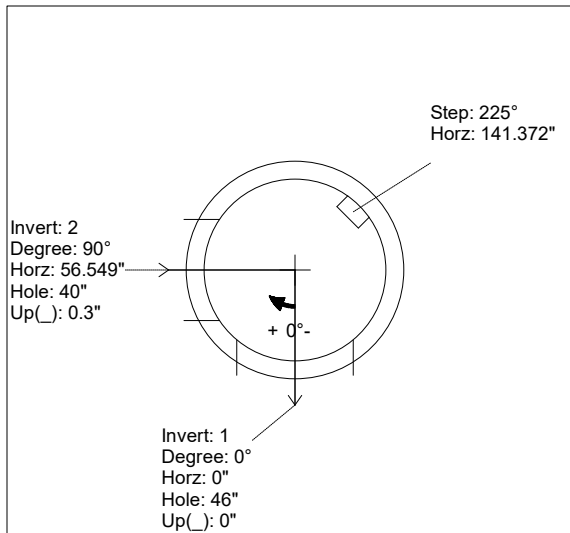
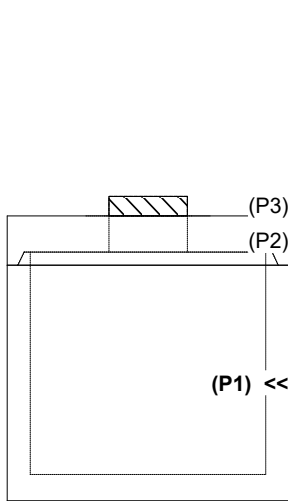

INSIDE WALL DIMENSIONS

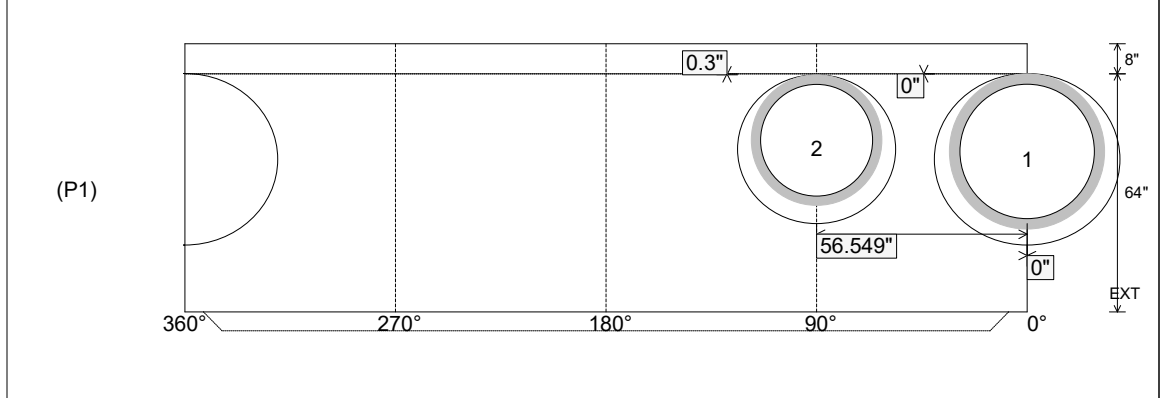

Coating (Int): Coating (Ext):	Seam Up: Tongue Seam Dn: n/a	Wall Thickness: 7" Floor Height: 8"	Height (Int): 64" Height (Ext): 72"	Weight (Net): 11410 lb Volume (Net): 2.91cu.yd
----------------------------------	---------------------------------	--	--	---