

Job Name: 25-1431 - Georgetown Commons
 Job Location: Georgetown, KY
 Contractor: Winwater Hartford KY Co.

Plant: Beaver Dam

Tech: J. Coppage

4/23/2026 11:31:57 AM

PC: A. Chambers



Structure ID: CBI 115

P2 MH060RSVF

MH RISER Custom Ht

- P5) 24" x 60" - CB INLET KY A 5' TOP LEFT - 10"
- P4) 24" x 60" - CB INLET KY A 5' BOTTOM LEFT - 18"
- P3) 60" - MH FLAT TOP w/24"x36" TRANS SLAB - 13"
- P2) 60" - MH RISER Custom Ht - 38"
- P1) 60" - MH BASE - 60"
- 2) 60" - Conseal CS-102 1.00"
- 1) 24" x 36" - Conseal CS-102 1.00"
- 2) Hole - 46
- 1) Hole - 6

1895 lb
 2670 lb
 2478 lb
 3953 lb
 7136 lb
 0 lb
 0 lb
 0 lb
 0 lb

 Structure Total: 18131 lb

- Structure Notes:**
1. JR HOE KY-206 PROVIDED BY ICAST.
 2. CASTING FRAME TO BE CAST INTO THE TOP PHASE.
 3. PER KYTC CBI TYPE A / ASTM C478 SPEC'S.
 4. CONCRETE = 4,000 PI AT 28 DAYS.
 5. REINFORCING PER ASTM A615 (GRADE 60).
 - TOP PHASE (As .62) #5 BARS AT 6" C.C.E.W.
 - WALLS (As .31) #5 BARS AT 12" C.C.E.W.
 - FLOOR (As .31) #5 BARS AT 12" C.C.E.W.

Rim: 871.98' Rim to Invert: 11.23' Slack: 0.76" Sump: 5" Step Position:

Position	Elev	Angle	Ext. (cw)	Pipe	Pipe OD	Connector	Hole	Horz Size	Up (↓)	Offset
Invert 1										
Invert 2										
Invert 3	867.83'	180°	113.097"	4" HDPE (perf pipe)	4.8"	Hole 6	6"	6.01"	24.21"	0"
Invert 4										
Invert 5										
Invert 6										
Invert 7										
Invert 8										

RIGHT-SIDE UP VIEW (int. dimensions)

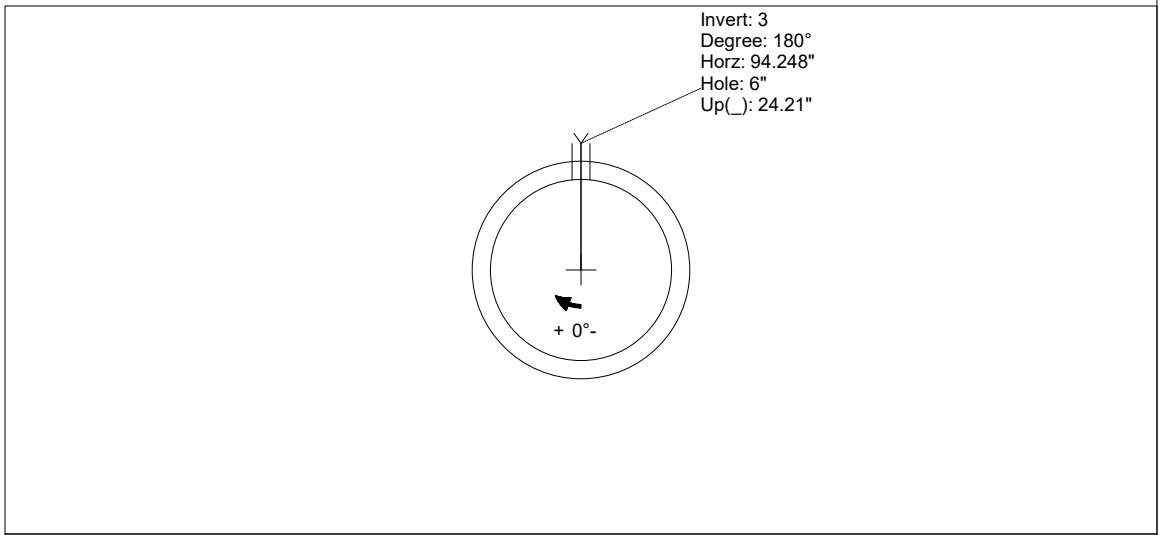

INSIDE WALL DIMENSIONS

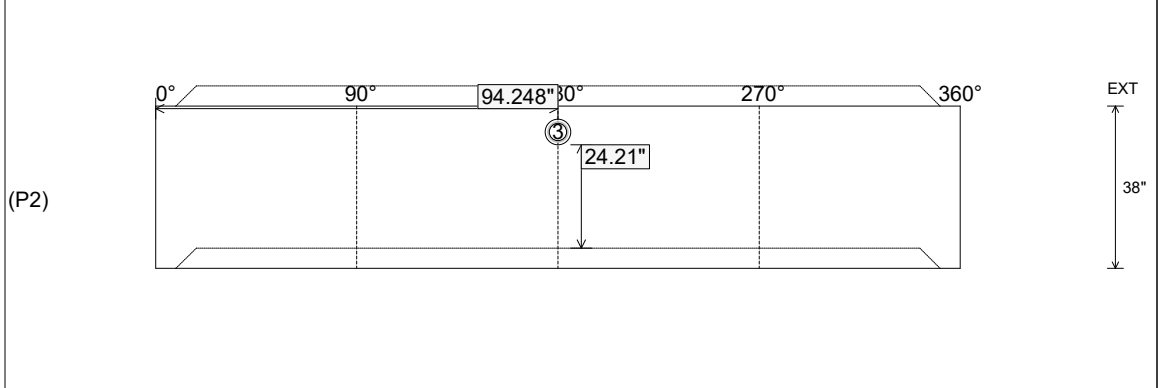

Coating (Int):
 Coating (Ext):

Seam Up: Tongue
 Seam Dn: Groove

Wall Thickness: 6"
 Floor Height: 0"

Height (Int): 38"
 Height (Ext): 38"

Weight (Net): 3953 lb
 Volume (Net): 1.01cu.yd