

Job Name: 25-1375D - 508-510 Southgate Ave
 Job Location: Nashville, TN
 Contractor: Hayes Pipe Supply

Plant: 100
 3/30/2026 1:49:15 PM

Tech: J. Horsley
 PC: E. Bradley



Structure ID: MH 2

P4 GR4CDARED

GRADE RING w/ConBlock-CDA Red F/F

- P5) 24" - CASTING HEIGHT - 7"
- P4) 24" - GRADE RING w/ConBlock-CDA Red F/F - 4"
- P3) 48" - ECC CONE w/ 24" HOLE, w/ConBlock-CDA Red F/G - 42"
- P2) 48" - MH RISER w/ConBlock-CDA Red T/G - 48"
- P1) 48" - MH BASE w/ConBlock-CDA Red T/n - 30"
- 1) JOINT WRAP - 0.065"x6"x50' CONSEAL CS212
- 1) JOINT WRAP PRIMER - CONSEAL CS-75 (1 gal.)
- 1) 48" - MH INVERT CHANNEL w/ConBlock-CDA Red - FULL HEIGHT
- 1) ADMIXTURE CONBLOCK CDA RED
- 2) 48" - Conseal CS-102 1.00" (Double)
- 1) PSX - 12-08 NYLO
- 10) MH Step ML-10-TDS-NCR - 10"

0 lb
 270 lb
 3116 lb
 3353 lb
 3378 lb
 0 lb
 0 lb
 1440 lb
 0 lb
 0 lb
 8 lb
 0 lb

Structure Total: 11566 lb

- Structure Notes:
1. PER ASTM C-478 SPECIFICATIONS
 2. CONCRETE: 4,000 PSI AT 28 DAYS
 3. REINFORCEMENT: (1) #3 HOOP CENTERED (GRADE 60)

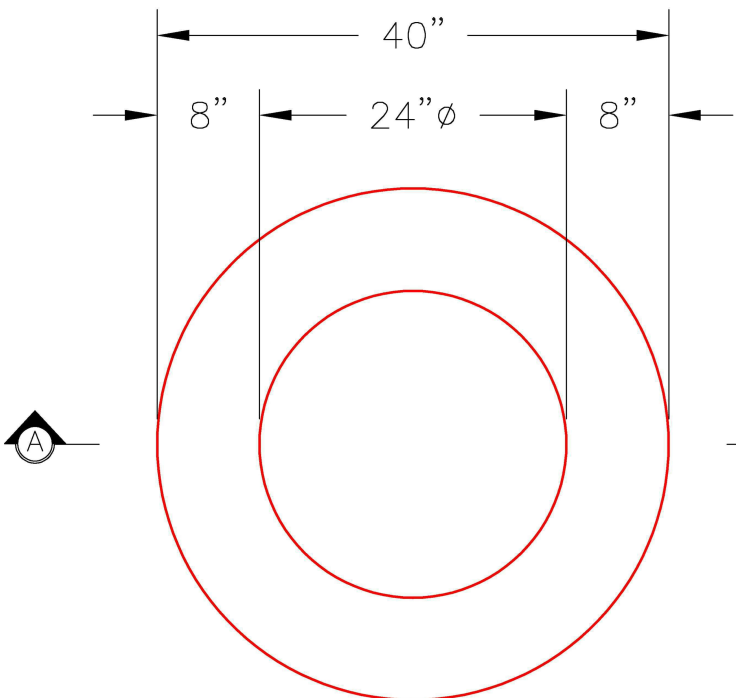

PLAN VIEW

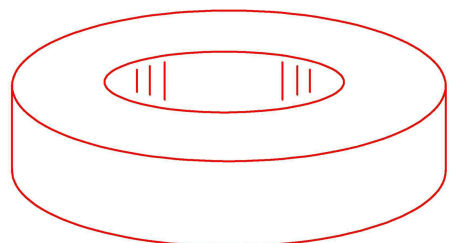

ISOMETRIC VIEW

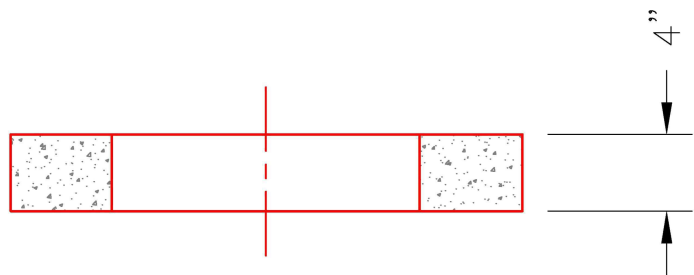

SECTION A-A

Coating (Int): Coating (Ext):	Seam Up: Flat Seam Dn: Flat	Wall Thickness: 8"	Height (Ext): 4"	Weight (Net): 270 lb Volume (Net): 0.07cu.yd
----------------------------------	--------------------------------	--------------------	------------------	---