

Job Name: 25-1375D - 508-510 Southgate Ave  
 Job Location: Nashville, TN  
 Contractor: Hayes Pipe Supply

Plant: 100  
 3/30/2026 1:49:14 PM

Tech: J. Horsley  
 PC: E. Bradley



**Structure ID: MH 2**

**P3 MH048CN42CDARED**

**ECC CONE w/ 24" HOLE, w/ConBlock-CDA Red F/G**

- P5) 24" - CASTING HEIGHT - 7"
- P4) 24" - GRADE RING w/ConBlock-CDA Red F/F - 4"
- P3) 48" - ECC CONE w/ 24" HOLE, w/ConBlock-CDA Red F/G - 42"
- P2) 48" - MH RISER w/ConBlock-CDA Red T/G - 48"
- P1) 48" - MH BASE w/ConBlock-CDA Red T/n - 30"
- 1) JOINT WRAP - 0.065"x6"x50' CONSEAL CS212
- 1) JOINT WRAP PRIMER - CONSEAL CS-75 (1 gal.)
- 1) 48" - MH INVERT CHANNEL w/ConBlock-CDA Red - FULL HEIGHT
- 1) ADMIXTURE CONBLOCK CDA RED
- 2) 48" - Conseal CS-102 1.00" (Double)
- 1) PSX - 12-08 NYLO
- 10) MH Step ML-10-TDS-NCR - 10"

0 lb  
 270 lb  
 3116 lb  
 3353 lb  
 3378 lb  
 0 lb  
 0 lb  
 1440 lb  
 0 lb  
 0 lb  
 0 lb  
 8 lb  
 0 lb  
 -----  
 Structure Total: 11566 lb

- Structure Notes:
1. PER ASTM C-478 SPECIFICATIONS
  2. CONCRETE: 4,000 PSI AT 28 DAYS
  3. REINFORCEMENT: PER ASTM A615
  4. STEPS REQUIRED
  5. CONBLOCK CDA RED ADMIXTURE REQUIRED
  6. JBS 1150 FRAME & COVER "SANITARY" SUPPLIED BY OTHERS

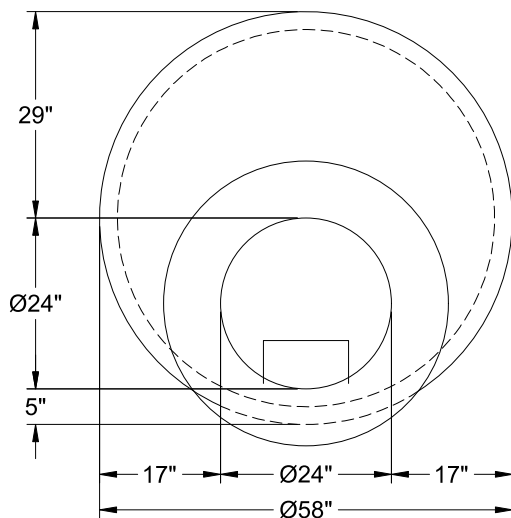

48" - ECC CONE w/ 24" HOLE, w/ConBlock-CDA Red F/G - 42" - (P3)

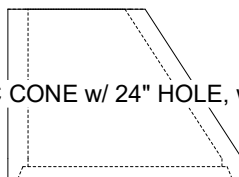

Coating (Int):  
 Coating (Ext):

Seam Up: Flat  
 Seam Dn: Groove

Wall Thickness: 5"

Height (Ext): 42"

Weight (Net): 3116 lb  
 Volume (Net): 0.8cu.yd