

Job Name: 25-1375D - 508-510 Southgate Ave
 Job Location: Nashville, TN
 Contractor: Hayes Pipe Supply

Plant: 100
 3/30/2026 1:49:14 PM

Tech: J. Horsley
 PC: E. Bradley



Structure ID: MH 1

P2 MH048CN36CDARED

ECC CONE w/ 24" HOLE, w/ConBlock-CDA Red F/G

- P3) 24" - CASTING HEIGHT - 7"
- P2) 48" - ECC CONE w/ 24" HOLE, w/ConBlock-CDA Red F/G - 36"
- P1) 48" - MH DH RISER Custom Ht, w/ConBlock-CDA Red T/F - 30"
- 1) JOINT WRAP - 0.065"x6"x50" CONSEAL CS212
- 1) JOINT WRAP PRIMER - CONSEAL CS-75 (1 gal.)
- 1) ADMIXTURE CONBLOCK CDA RED
- 1) 48" - Conseal CS-102 1.00" (Double)
- 1) DOGHOUSE - 12"x14"
- 1) DOGHOUSE - 12"x14.25"
- 1) PSX - 12-08 NYLO
- 5) MH Step ML-10-TDS-NCR - 10"

0 lb
 2251 lb
 1918 lb
 0 lb
 0 lb
 0 lb
 0 lb
 0 lb
 0 lb
 8 lb
 0 lb

 Structure Total: 4177 lb

- Structure Notes:
1. PER ASTM C-478 SPECIFICATIONS
 2. CONCRETE: 4,000 PSI AT 28 DAYS
 3. REINFORCEMENT: PER ASTM A615
 4. STEPS REQUIRED
 5. CONBLOCK CDA RED ADMIXTURE REQUIRED
 6. JBS 1150 FRAME & COVER "SANITARY" SUPPLIED BY OTHERS

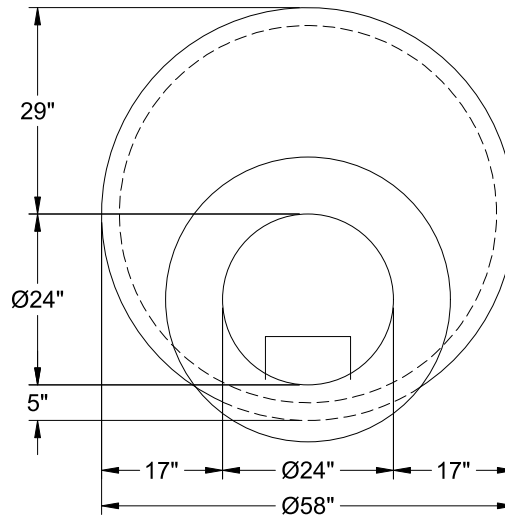

48" - ECC CONE w/ 24" HOLE, w/ConBlock-CDA Red F/G - 36" - (P2)



Coating (Int):
 Coating (Ext):

Seam Up: Flat
 Seam Dn: Groove

Wall Thickness: 5"

Height (Ext): 36"

Weight (Net): 2251 lb
 Volume (Net): 0.57cu.yd