

Job Name: 25-1308 UPS BUILDING 1860  
 Job Location: Louisville, KY  
 Contractor: Hall Contracting of Kentucky Inc

Plant: Beaver Dam

Tech: C.Russ

11/10/2025 10:30:02 AM

PC: J.Jarvis



**Structure ID: 30"X12" RCP BLIND TEE 4**

**P1 BX4848-08BAVF**

**BOX BASE 8inW, 8inF, Variable Ht**

- P3) CASTING HEIGHT - 0"
- P2) 48" x 48" - BX FLAT LID 8inW SOLID - 8"
- P1) 48" x 48" - BOX BASE 8inW, 8inF, Variable Ht - 41"
- 1) 48" x 48" - STORM INVERT CHANNEL (FLAT) - 4" THK
- 2) Hole - 40
- 1) Hole - 20
- 4) MH Step ML-10-TDS-NCR - 10"

- Structure Notes:
1. PER ASTM C478 SPECIFICATIONS.
  2. CONCRETE = 4,000 PSI AT 28 DAYS.
  3. NO CASTING.
  4. REINFORCING PER ASTM A615 (GRADE 60).
    - TOP SLAB (As .62) #5 BARS AT 6" C.C.E.W..
    - RISER/WALLS (As .18)
    - FLOOR (As .37) #5 BARS AT 10" C.C.E.W.

Structure Total: 10225 lb

Rim: 4.08' Rim to Invert: 4.08' Slack: 0" Sump: 0.04" Step Position: 90°

Position	Elev	Angle	Ext. (cw)	Pipe	Pipe OD	Connector	Hole	Horz Size	Up ( )	Offset
Invert 1	0'	0°	32"	30" RCP B WALL	37"	Hole 40	40"	40"	-3.46"	0"
Invert 2	0'	180°	32"	30" RCP B WALL	37"	Hole 40	40"	40"	-3.46"	0"
Invert 3	0'	270°	32"	12" RCP B WALL	16"	Hole 20	20"	20"	-1.96"	0"
Invert 4										
Invert 5										
Invert 6										
Invert 7										
Invert 8										

RIGHT-SIDE UP VIEW (int. dimensions)

UPSIDE-DOWN VIEW (int. dimensions)

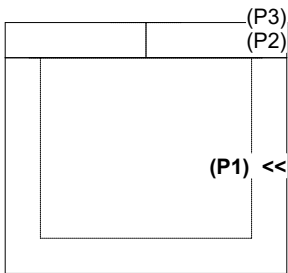
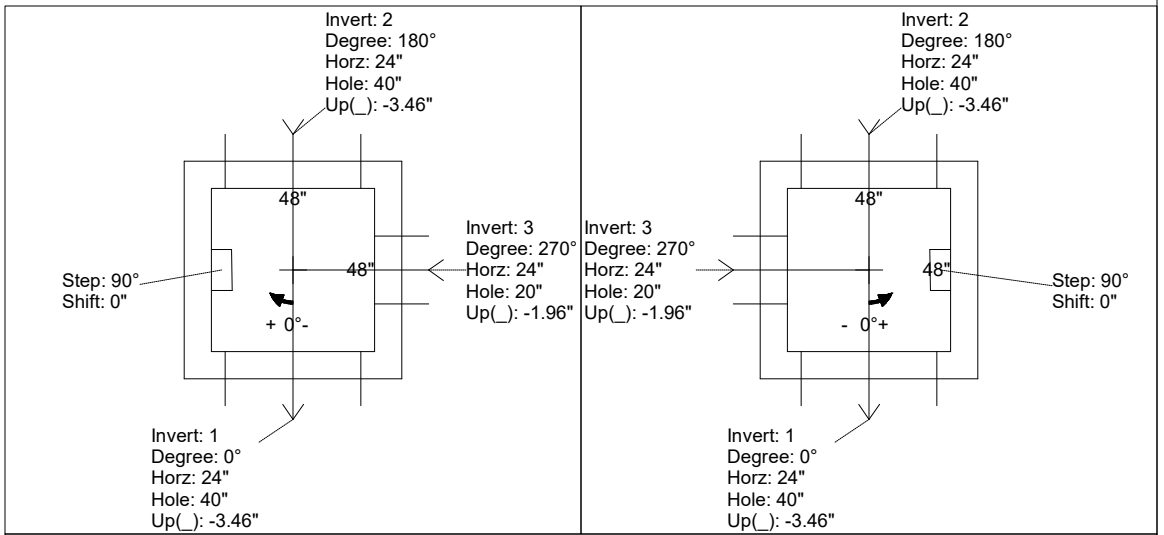

INSIDE WALL DIMENSIONS

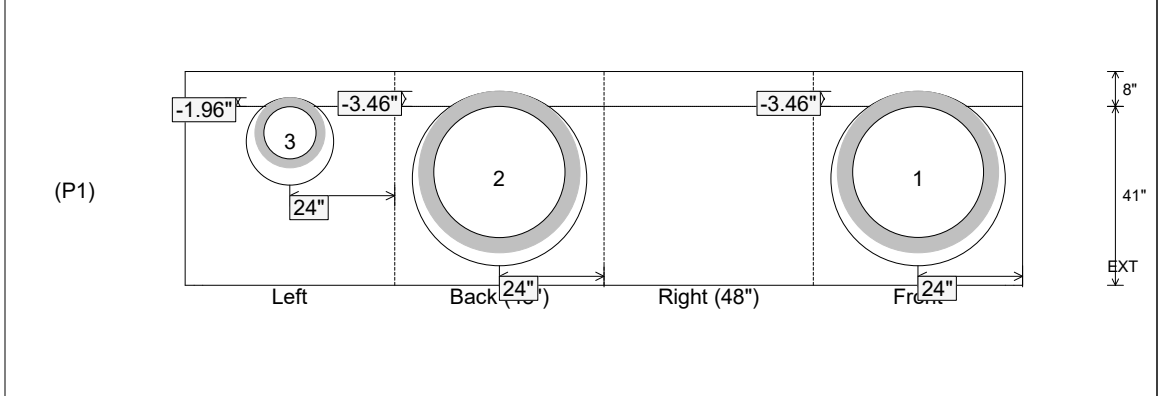

Coating (Int): Coating (Ext):	Seam Up: Flat Seam Dn: n/a	Wall Thickness: 8" Floor Height: 8"	Height (Int): 41" Height (Ext): 49"	Weight (Net): 7017 lb Volume (Net): 1.79cu.yd
----------------------------------	-------------------------------	--	--	--

Job Name: 25-1308 UPS BUILDING 1860  
 Job Location: Louisville, KY  
 Contractor: Hall Contracting of Kentucky Inc

Plant: Beaver Dam

Tech: C.Russ

11/10/2025 10:30:02 AM

PC: J.Jarvis



**Structure ID: 30"X12" RCP BLIND TEE 4**

**P1 BX4848-08BAVF**

**BOX BASE 8inW, 8inF, Variable Ht**

- P3) CASTING HEIGHT - 0"
- P2) 48" x 48" - BX FLAT LID 8inW SOLID - 8"
- P1) 48" x 48" - BOX BASE 8inW, 8inF, Variable Ht - 41"
- 1) 48" x 48" - STORM INVERT CHANNEL (FLAT) - 4" THK
- 2) Hole - 40
- 1) Hole - 20
- 4) MH Step ML-10-TDS-NCR - 10"

- Structure Notes:
1. PER ASTM C478 SPECIFICATIONS.
  2. CONCRETE = 4,000 PSI AT 28 DAYS.
  3. NO CASTING.
  4. REINFORCING PER ASTM A615 (GRADE 60).
    - TOP SLAB (As .62) #5 BARS AT 6" C.C.E.W..
    - RISER/WALLS (As .18)
    - FLOOR (As .37) #5 BARS AT 10" C.C.E.W.

Structure Total: 10225 lb

**STORM INVERT CHANNEL DRAWING  
4" HEIGHT INVERT**

Rim: 4.08' Rim to Invert: 4.08' Slack: 0" Sump: 0.04" Step Position: 90°

Position	Elev	Angle	Ext. (cw)	Pipe	Pipe OD	Connector	Hole	Horz Size	Up ( )	Offset
Invert 1	0'	0°	32"	30" RCP B WALL	37"	Hole 40	40"	40"	-3.46"	0"
Invert 2	0'	180°	32"	30" RCP B WALL	37"	Hole 40	40"	40"	-3.46"	0"
Invert 3	0'	270°	32"	12" RCP B WALL	16"	Hole 20	20"	20"	-1.96"	0"
Invert 4										
Invert 5										
Invert 6										
Invert 7										
Invert 8										

RIGHT-SIDE UP VIEW (int. dimensions)

UPSIDE-DOWN VIEW (int. dimensions)

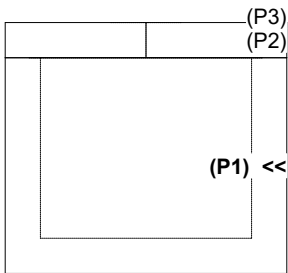
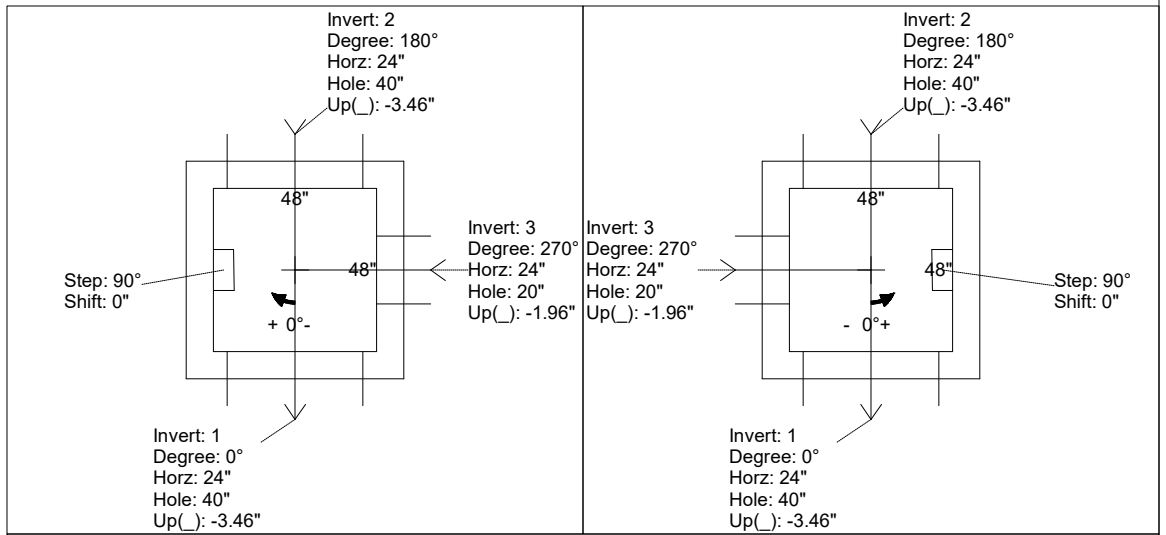

INSIDE WALL DIMENSIONS

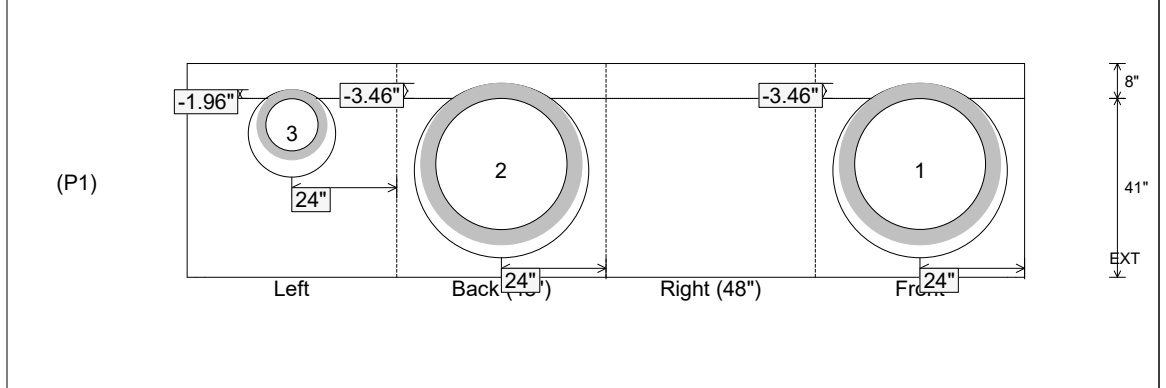

Coating (Int): Coating (Ext):	Seam Up: Flat Seam Dn: n/a	Wall Thickness: 8" Floor Height: 8"	Height (Int): 41" Height (Ext): 49"	Weight (Net): 7017 lb Volume (Net): 1.79cu.yd
----------------------------------	-------------------------------	--	--	--