

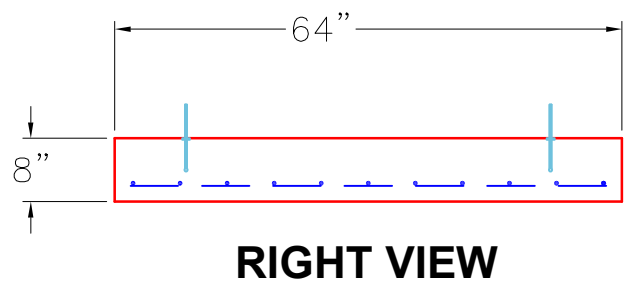

GENERAL NOTES:

1. MANUFACTURED TO ASTM C-913 (LATEST REVISION).
2. CONCRETE: 4,000 PSI AT 28 DAYS.
3. REINFORCING: #5 BAR @ 6" E.W. O.C. (GRADE 60).
4. WEIGHT: 2,758 LBS

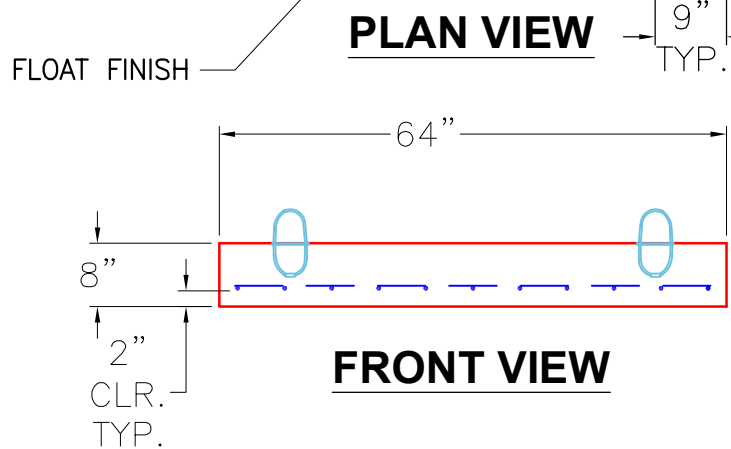

PRODUCTION WORK ORDER		PRODUCT I.D.: BXLD4848FL-S	DESCRIPTION: 64" X 64" X 8" THICK SLAB SOLID	
	QUALITY CONTROL CHECKLIST	PRODUCT VIEW: RIGHT SIDE UP	CUSTOMER: HALL CONTRACTING OF KENTUCKY INC	
	<input type="checkbox"/> ALL DIMENSIONS CORRECT.	PLANT: BEAVER DAM, KY.	PROJECT: UPS BUILDING 1860	
	<input type="checkbox"/> LIFTERS INSTALLED.	WEIGHT: 2,758 LBS.	STRUCTURE: 30"X12" RCP BLIND ELBOW 2	
	<input type="checkbox"/> OPENING CENTERED.	TOP SECTION JOINT: N/A	ORDER NO: 25-1308	
	<input type="checkbox"/> REINFORCING CORRECT.	BASE SECTION JOINT: N/A	PC: J. JARVIS	DRAWING: J. COPPAGE
<input type="checkbox"/> SURFACE QUALITY ACCEPTABLE.	QC CHECK INITIALS:	DATE: 11/10/25	SCALE: NTS	PG. 1 of 1
<input type="checkbox"/> EDGES CHAMFERED.				
<input type="checkbox"/> ALL PATCHWORK ACCEPTABLE.				