

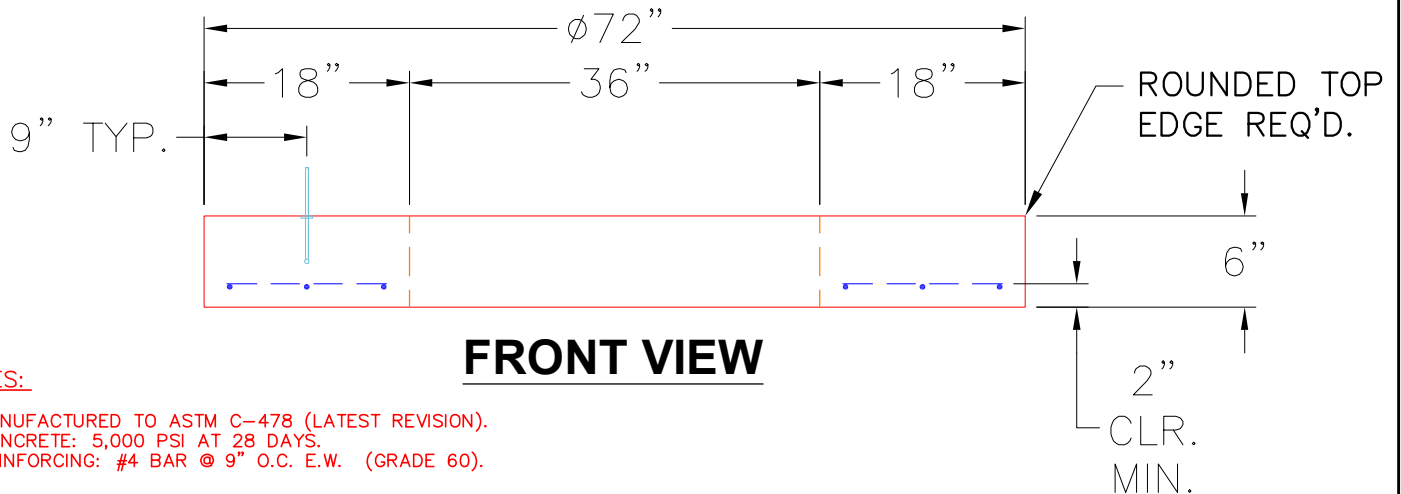

THIS DRAWING IS INTENDED TO BE PRINTED IN COLOR.

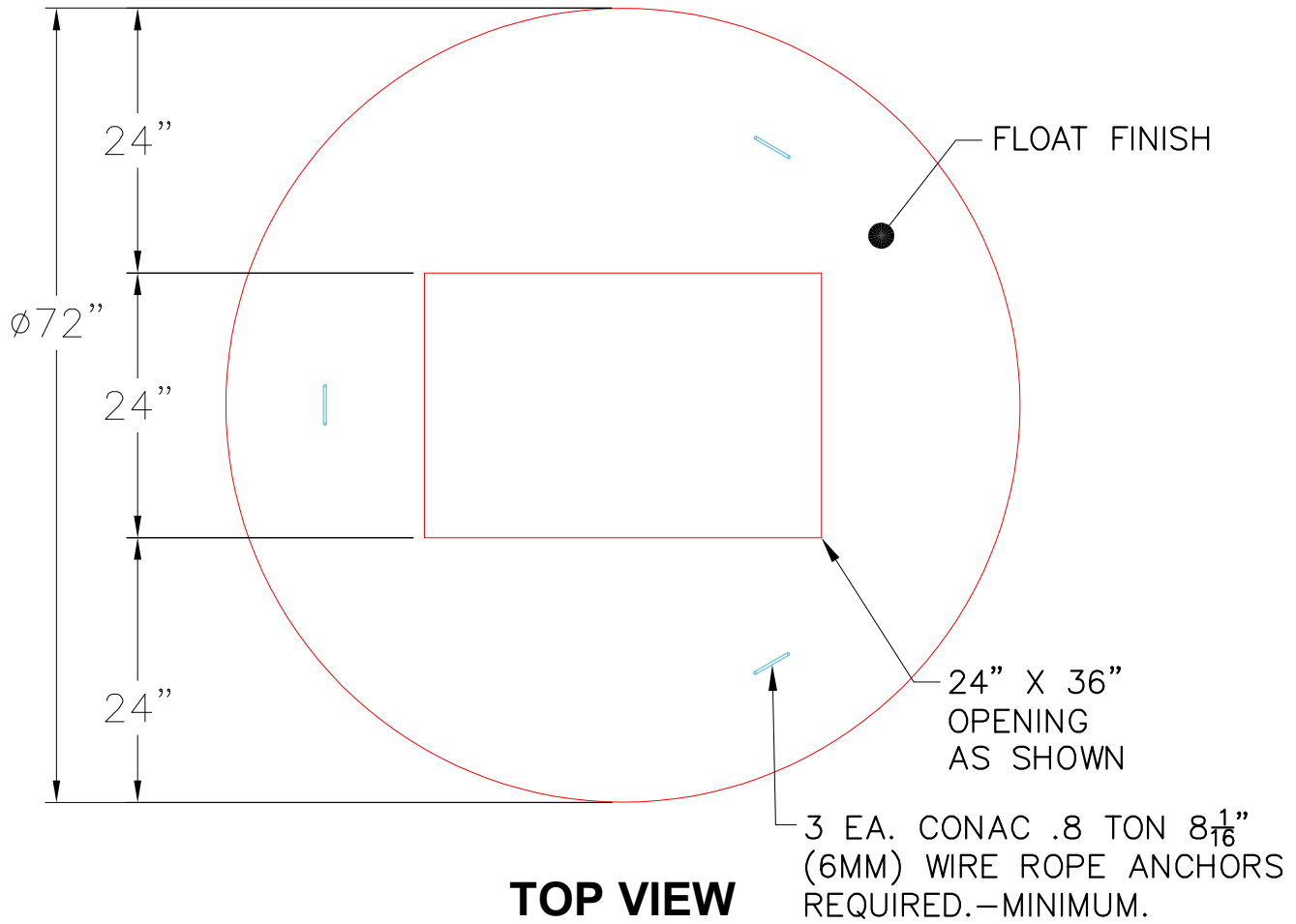

NOTES:

1. MANUFACTURED TO ASTM C-478 (LATEST REVISION).
2. CONCRETE: 5,000 PSI AT 28 DAYS.
3. REINFORCING: #4 BAR @ 9" O.C. E.W. (GRADE 60).

PRODUCTION WORK ORDER		PRODUCT I.D.: MH06LD06SP	DESCRIPTION: 60"ø X 6" MH TOP SLAB 24" X 36" OPENING	
	QUALITY CONTROL CHECKLIST		PRODUCT VIEW: RIGHT SIDE UP	
	<input type="checkbox"/> ALL DIMENSIONS CORRECT.		CUSTOMER: WINWATER HARTFORD KY CO.	
	<input type="checkbox"/> LIFTERS INSTALLED.		PROJECT: OWENSBORO GROCERY	
	<input type="checkbox"/> HOLE LOCATION CORRECT.		STRUCTURE: CBI-A5.1	
	<input type="checkbox"/> REINFORCING CORRECT.		QUOTE/SALES ORDER NO: 25-1267B	
	<input type="checkbox"/> FINISH ON SLAB SURFACE UNIFORM.		PC: A. CHAMBERS	
<input type="checkbox"/> OUTSIDE TOP EDGE TROWELLED.		DRAWING: J. COPPAGE		
<input type="checkbox"/> FLAT BOTTOM.		DATE: 9/18/25		
QC CHECK INITIALS:		SCALE: NTS		
		PG. 1 of 1		